

# Volume XI: Thermoplastic Valves

Industrial Technical  
Manual Series

FIRST EDITION

## IPEX THERMOPLASTIC VALVES

- Ball Valves
- Butterfly Valves
- Diaphragm Valves
- Check and Vent Valves
- Specialty Valves



**IPEX**

# Thermoplastic Valves

Industrial Technical Manual Series

Vol. XI, 1st Edition

© 2008 by IPEX. All rights reserved. No part of this book may be used or reproduced in any manner whatsoever without prior written permission. For information contact: IPEX, Marketing, 2441 Royal Windsor Drive, Mississauga, Ontario, Canada, L5J 4C7.

The information contained here within is based on current information and product design at the time of publication and is subject to change without notification. IPEX does not guarantee or warranty the accuracy, suitability for particular applications, or results to be obtained therefrom.

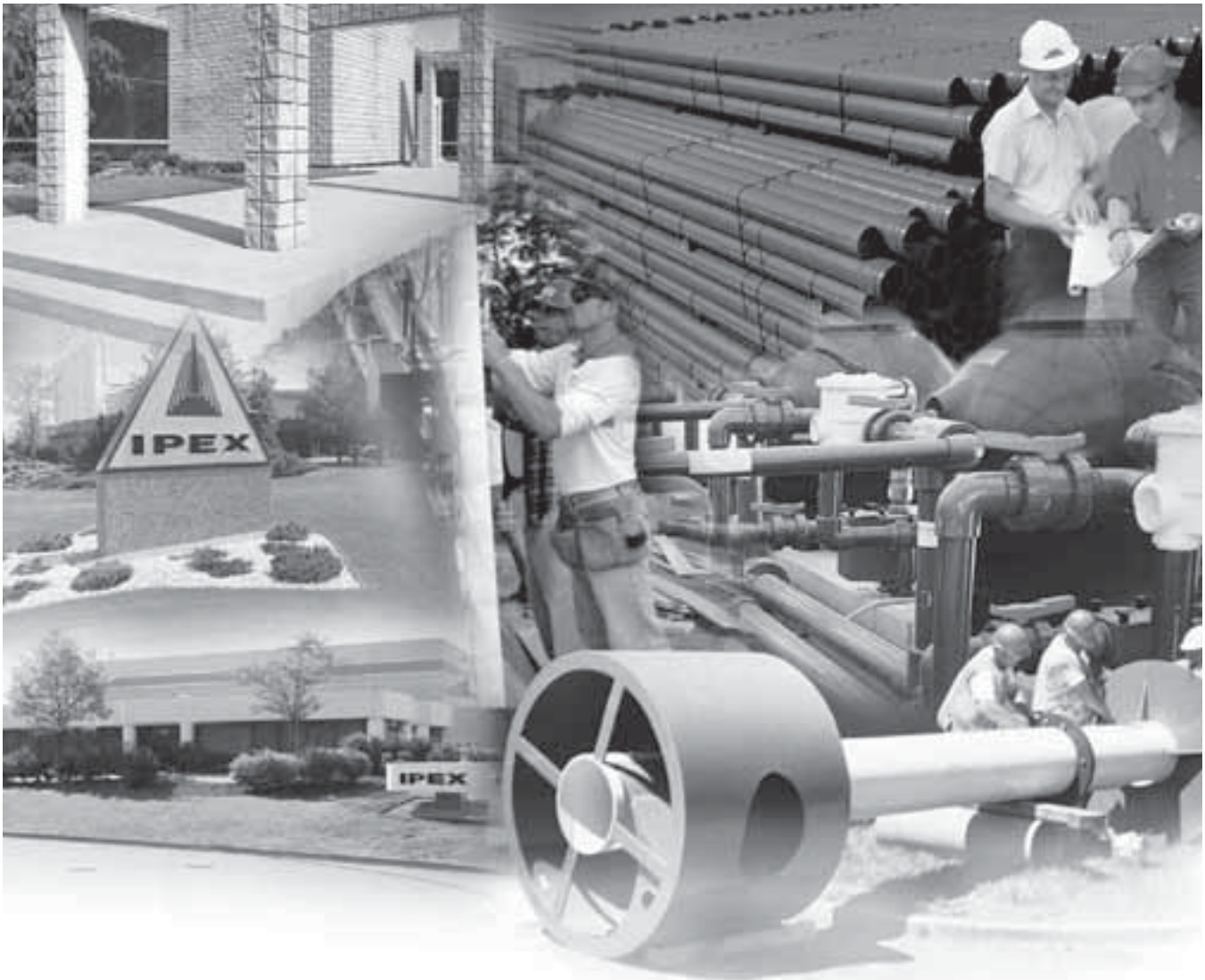

## ABOUT IPEX

At IPEX, we have been manufacturing non-metallic pipe and fittings since 1951. We formulate our own compounds and maintain strict quality control during production. Our products are made available for customers thanks to a network of regional stocking locations throughout North America. We offer a wide variety of systems including complete lines of piping, fittings, valves and custom-fabricated items.

More importantly, we are committed to meeting our customers' needs. As a leader in the plastic piping industry, IPEX continually develops new products, modernizes manufacturing facilities and acquires innovative process technology. In addition, our staff take pride in their work, making available to customers their extensive thermoplastic knowledge and field experience. IPEX personnel are committed to improving the safety, reliability and performance of thermoplastic materials. We are involved in several standards committees and are members of and/or comply with the organizations listed on this page.

For specific details about any IPEX product, contact our customer service department.



## SAFETY ALERTS

Engineered thermoplastics are safe inert materials that do not pose any significant safety or environmental hazards during handling or installation. However, improper installation or use can result in personal injury and/or property damage. It is important to be aware of and recognize safety alert messages as they appear in this manual.

The types of safety alert messages are described below.



This safety alert symbol indicates important safety messages in this manual. When you see this symbol be alert to the possibility of personal injury and carefully read and fully understand the message that follows.



### WARNING

“WARNING” identifies hazards or unsafe practices that can result in severe personal injury or death if instructions, including recommended precautions, are not followed.



### CAUTION

“CAUTION” identifies hazards or unsafe practices that can result in minor personal injury or product or property damage if instructions, including recommended precautions, are not followed.

**Note:** The use of the word “NOTE” signifies special instructions which are important but are not related to hazards.

For the materials described in this manual, the following warning applies.



### WARNING



- **NEVER** use compressed air or gas in PVC/CPVC/PP/PVDF pipe and fittings.
- **NEVER** test PVC/CPVC/PP/PVDF pipe and fittings with compressed air or gas, or air-over-water boosters.
- **ONLY** use PVC/CPVC/PP/PVDF pipe for water and approved chemicals.

Use of compressed air or gas in PVC/CPVC/PP/PVDF pipe and fittings can result in explosive failures and cause severe injury or death.



# CONTENTS

## Thermoplastic Valves Manual

About IPEX

Safety Alerts ..... *i*

### Section One: General Information

Overview ..... 1

Features and Benefits ..... 2

Applications ..... 3

Material Description ..... 4

Valve Types ..... 5

Valve Selection ..... 7

Further Information ..... 8

### Section Two: Ball Valves

VKD Series Ball Valves ..... 9

VX Series Ball Valves ..... 18

VE Series Ball Valves ..... 25

MP Series Compact Ball Valves ..... 31

TK Series 3-Way Ball Valves ..... 35

TKD Series 3-Way Ball Valves ..... 45

VT Series 3-Way Ball Valves ..... 55

### Section Three: Butterfly Valves

FK Series Butterfly Valves ..... 65

FE Series Butterfly Valves ..... 75

### Section Four: Diaphragm Valves

VM Series Manual Diaphragm Valves ..... 85

VM Series Pneumatic Diaphragm Valves ..... 93

DV Series Diaphragm Valves ..... 105

CM Series Compact Diaphragm Valves ..... 111

DM Series Diaphragm Valves ..... 122

**Section Five: Check and Vent Valves**

VB Series Ball Check Valves . . . . . 129  
VR Series Piston Check Valves . . . . . 134  
SC Series Swing Check Valves . . . . . 145  
VA Series Air Release Valves . . . . . 150

**Section Six: Specialty Valves**

RV Series Sediment Strainers . . . . . 155  
SF Series Solenoid Valves . . . . . 165  
LV Series Lab Valves . . . . . 171

**Section Seven: Standards**

Standards Organizations . . . . . 175  
Applicable Standards . . . . . 175

**Valve Application Assistance Form**

## SECTION ONE: GENERAL INFORMATION

### OVERVIEW

This manual provides the most up-to-date and comprehensive information about IPEX valves. Written with the needs of the engineer and contractor in mind, all aspects of our valves are covered. This includes material properties, specifications, valve types and selection, installation, as well as testing and operating considerations.

With more than 50 years of design and manufacturing experience, these lightweight, long life and maintenance free valves save both time and money. Our high-tech automated manufacturing and testing facility ensures unparalleled reliability for each and every valve.

IPEX quality engineered products include many unique characteristics ranging from important safety features, to simple ergonomic and aesthetic benefits. Material options such as PVC, CPVC, PP, PVDF, and ABS make our corrosion resistant valves ideal for use in a wide variety of demanding applications.

IPEX thermoplastic valves are part of our complete systems of pipe, valves, and fittings, engineered and manufactured to our strict quality, performance, and dimensional standards. Our network of manufacturing and customer service facilities across North America ensures fast, reliable service, and expert technical support.



## FEATURES AND BENEFITS

IPEX valves have extensive features and benefits unrivalled by the competition. The compact and double blocking design of our ball valves makes them easy to install, yet safe while conducting line maintenance. Machined components and anti-frictions rings result in reduced seal wear and minimal breakaway torque on all our quarter turn valves. Ergonomic handles with incorporated safety lockouts can be removed to reveal integrated ISO pads for direct mount actuation. Many of our valves feature deep square style threads for improved strength and reliability as well as thick o-rings and deep grooves for maximum sealing. For a complete list of features and benefits, please consult the Thermoplastic Valve Multimedia CD or the specific valve literature.



## APPLICATIONS



### Industrial and Process Piping

- Plant Water Supply and Distribution Lines
- Cooling Water Systems
- Chemical and Washwater Systems for Photographic Laboratories
- Acid Products Handling for Refineries, Metal Works and Plating Plants
- Bleach, Dye and Acid Lines in Textile Mills
- Deionized Water
- Tailing and Slurry Lines in Mines, Smelters and Fertilizer Plants
- Vacuum Piping
- Pure Chemicals for Semiconductor & Pharmaceutical Industries
- Piping in Fish Hatcheries, Aquariums, Zoological and Biological Buildings
- Well Casings and Dewatering Lines
- Drainage and Effluent Piping
- Swimming Pool Piping
- Rainwater Leaders for Buildings



### Pulp and Paper

- Pulp/Chemical Recovery Systems
- Bleach Plant Piping Systems
- Washwater Piping and Lagoon Systems



### Food Processing

- Brine and Seawater Distribution in Fish Plants
- Brine Systems in Meat Packaging Plants
- Piping for the Dairy, Canning and Beverage Industries

### Water and Sewage Treatment

- Alum and Ferric Chloride Handling
- Chlorine Injection Systems
- Piping in Lagoons and Settling Ponds
- Rainwater Lines



### Irrigation

- Golf Courses
- Greenhouses
- Agriculture
- Residential Turf
- Commercial Turf

## MATERIAL DESCRIPTION

### PVC (Polyvinyl Chloride)

PVC is the most frequently specified of all thermoplastic materials and has been used successfully for over 60 years. PVC is characterized by distinctive physical properties, and is resistant to corrosion and chemical attack by acids, alkalis, salt solutions and many other chemicals. It is attacked, however, by polar solvents such as ketones and aromatics. Of the various types and grades of PVC used in plastic piping systems, Type 1, Grade 1 PVC (Cell Classification 12454) conforming to ASTM D1784 is the most common.

### CPVC (Chlorinated Polyvinyl Chloride)

CPVC (Cell Classification 23447) conforming to ASTM D1784 has physical properties at 73°F (23°C) similar to those of PVC and chemical resistance similar to or generally better than that of PVC. With a design stress of 2,000psi and maximum service temperature of 210°F (99°C), CPVC has proved to be an excellent material for hot corrosive liquids, hot and cold water distribution and similar applications above the temperature range of PVC.

### PP (Polypropylene)

Polypropylene is a lightweight polyolefin that is generally high in chemical resistance. Although Type 1 Polypropylene conforming to ASTM D2146 is slightly lower in physical properties than PVC, it is chemically resistant to organic solvents as well as acids and alkalies. Generally, polypropylene should not be used in contact with strong oxidizing acids, chlorinated hydrocarbons and aromatics. Polypropylene has a design stress of 1,000psi at 73°F (23°C).

### PVDF (Polyvinylidene Fluoride)

Polyvinylidene Fluoride is a strong, abrasion-resistant thermoplastic with excellent heat stability and chemical resistance typical of fluorocarbon polymers. It can be used in temperatures up to 300°F (149°C) with a wide variety of acids, bases and organic solvents, and is ideally suited for handling wet or dry chlorine, bromine and other halogens. No other thermoplastic piping material can approach the combination of strength, chemical resistance and operating temperature that PVDF piping systems can offer.

### ABS (Acrylonitrile-Butadiene-Styrene)

ABS identifies a broad family of engineering thermoplastics with a range of performance characteristics. The copolymeric system can be blended to yield the optimum balance of properties suited to a selected end use. Acrylonitrile imparts chemical resistance and rigidity. Butadiene endows the product with impact strength and toughness, while Styrene contributes to ease of processing.

### EPDM (Ethylene propylene diene monomer)

EPDM is the abbreviation, issued by ASTM, for elastomers derived from the propylene and ethylene copolymer. The absence of unsaturation groups at the molecular level gives EPDM excellent resistance to oxidation products but will show a certain swelling when in contact with mineral and petroleum oils, diester base lubricants and organic solvents. Its operating temperature ranges from -65°F to 284°F (-54°C to 140°C).

### FPM (Vinylidene fluorine rubber)

FPM is the abbreviation, issued by ASTM, for fluorocarbon elastomers derived from vinylidene fluorine copolymers. Trade names include Viton A&B™ or Tecnoflon™. Characterized by excellent resistance to heat and chemical agents, FPM is virtually inert to oil and most solvents and exhibits good chemical resistance to many aromatic and aliphatic hydrocarbons. Its working temperature range is considered to be from -13°F to 392°F (-25°C to 200°C) although it has been known to seal at very low temperatures such as -58°F (-50°C).

### PTFE (Polytetrafluorethylene)

PTFE or polytetrafluorethylene is a fluorinated polymer characterized by a high molecular weight and a nearly complete chemical resistance to reactives and solvents. Thanks to its characteristics of self-lubrication, shock resistance and extraordinary chemical inertness, polytetrafluorethylene polymers, under trade names such as Teflon™, Fluon™ and Argoflon™, have been successfully used in the manufacture of sealing components. Among thermoplastic resins, PTFE allows the highest working temperatures. It can be used at constant temperatures of up to 500°F (260°C).

## VALVE TYPES

By definition, a valve is any device that regulates the flow of gases, liquids, or loose materials through piping or through apertures by opening, closing, or obstructing ports or passageways. Some main categories of valve types are as follows:

### Ball Valves

Ball valves are generally used for on/off service, but can range from simple molded-in-place construction to high-end industrial designs with many features and benefits. Multi-port ball valves allow for mixing, diverting, and bypassing flow. Their name is derived from the modified ball in the center of the valve which allows flow to enter and exit through two or more ports. This ball is tightly held between multiple seats, and is cycled via a stem-handle connection. They are typically categorized as "quarter turn" or 90° valves, and can be easily automated. Many ball valves feature full port flow, blocking true union ends, and compact ergonomic designs allowing for simple installation and maintenance.



### Butterfly Valves

These highly versatile valves can be used for simple on/off service but also for processes requiring precise throttling. They get their name from the stem-disc assembly that controls the flow. Cycling the valve just 90° allows full travel from the closed position (disc perpendicular to the pipeline) to the open position (disc parallel to the pipeline) or vice versa. A continuous flow profile between fully closed and fully open makes these valves ideal for use in modulating service. While typically connected to the system between two flanges, end-of-line installation is possible while maintaining pressure upstream. An extensive size range and direct mount actuation make them suitable for a wide range of applications.



### Diaphragm Valves

These valves are the perfect solution when precise flow throttling is required. Their design employs a flexible "diaphragm" component which is compressed against the body of the valve to provide a bubble tight seal. The weir style design is extremely good for abrasive slurries as there is no "dead space" for particles to become trapped. They are widely used in high purity applications because their design prevents friction and subsequent particle creation when cycling. Only the body and diaphragm are in contact with the process media. Due to the modular nature of the design, many body styles, diaphragm and seal materials, and actuation options are available.



### Check and Vent Valves

Check valves are unidirectional and should be used whenever there is a need to prevent back-flow of process media. This may be when two incompatible fluids cannot be allowed to mix, or when reverse flow would cause undesirable drainage of a system line or tank. Many styles exist including: simple ball checks, heavy duty swing checks, and highly efficient piston checks. These valves are typically gravity operated and require very little back pressure seal. Air release or vent valves safely allow any entrapped air or gas to escape, avoiding potential damage to the piping system.



### Specialty Valves

IPEX offers a few specialized valves for a variety of process requirements. Sediment strainers trap suspended particles flowing in the process line, ensuring that downstream components are protected. Solenoid valves are ideal for high-cycle applications where remote operation and precise control are important. Lab valves are an economical solution for small scale on/off requirements.



The following table should be used as a guide only as some valves only offer certain combinations of sizes, materials, connections, and pressure capabilities. **Always consult the specific valve style section for complete information regarding availability and technical performance.**

### IPEX Thermoplastic Valves

Valve Series	Valve Type	Sizes (in)	Materials	End Connections	Pressure Rating (PSI)
VKD	Ball	1/2 to 4	PVC, CPVC, PP, ABS	TU (S, T), Sm	232
VX	Ball	1/2 to 6	PVC, CPVC	TU (S, T), F	232 (1/2" to 2") 150 (2-1/2" to 4")
VE	Ball	1/2 to 2	PVC	TU (S, T)	232
MP	Compact Ball	1/2 to 2	PVC	S, T	150
TK	3-Way Ball	1/2 to 2	PVC	TU (S, T)	232
VT/VL	3-Way Ball	1/2 to 2	PVC, PP	TU (S, T), F, Sm	150
FK	Butterfly	1-1/2 to 12	PP, PVC, CPVC, PVDF	F (W, L)	150 (1-1/2" to 10") 120 (12")
FE	Butterfly	1-1/2 to 12	PVC	F (W)	232 (1/2" to 2") 150 (2-1/2" to 8") 75 (10" to 12")
VM	Diaphragm	1/2 to 4 20 to 110 (mm)	PVC, CPVC, PP, PVDF	TU (S, T), F, Sp, Sm	150
DV	Diaphragm	1/2 to 6	PVC	F	150
CM	Compact Diaphragm	1/2 16 to 20 (mm)	PVC, CPVC, PP, PVDF	TU (S, T), Sp, Sm	90
DM	Diaphragm	1/2 to 2	PVC	TU (S, T), F, Sp	120
VB	Ball Check	1/2 to 4	PVC, CPVC	TU (S, T), F	150
VR	Piston Check	1/2 to 4	PVC	TU (S, T), S, T, F	232 (1/2" to 1") 150 (1-1/4" to 2") 90 (3" to 4")
SC	Swing Check	3 to 8	PVC	F	100 (3") 70 (4" to 8")
VA	Air Release	3/4, 1-1/4, 2	PVC	SU (S, T)	232
RV	Strainer	1/2 to 4	PVC, CPVC	TU (S, T), S, T, F	232 (1/2" to 1") 150 (1-1/4" to 2") 60 (3" to 4")
SF	Solenoid	1/4, 1/2	PVC	TU (T)	30 (1/4) 60 (1/2)
LV	Lab	1/4	PVC	T	150

TU = True Union, SU = Single Union, S = Socket (IPS), T = Threaded (NPT), F = Flanged (ANSI 150),  
W = Wafer, L = Lugged, Si = Spigot (IPS), Sm = Socket (Metric), Sp = Spigot (Metric)

## VALVE SELECTION

As is the case with other thermoplastic components in a processing system, valves must be selected based on the characteristics of the fluid medium, the system's operating parameters, and its intended function for a particular application. Certain valve types are more suitable than others for on/off service, throttling or modulating, automation, back flow prevention, etc.

### Fluid Properties

Like other system components, the material that is used in valve construction should be chosen depending on the chemistry of the fluid. Different plastics have varying abilities to handle certain chemical types. In a given piping system, the material selected for a valve is typically the same as what is specified for the pipe and fittings. However, since valves contain other components such as seats and seals, particular attention should be paid to their material selection. Please consult IPEX's Chemical Resistance Guide for specific material-fluid compatibilities. Abrasiveness, viscosity, and other fluid properties are sometimes important to consider as well.

### Temperature and Pressure

As with pipe and fittings, the strength of a valve is limited by the operating temperature and pressure of the system. However, the type of failure that can be expected in valves is different than that of other piping components as valves typically contain seats, seals, and moving components. These critical points can be potentially displaced if the seat or seal housing softens or distorts due to excessive prolonged heat. This can result in a loss of pressure capacity if these contact points lose competence. During the design, manufacture, and assembly of IPEX valves, careful attention is given to these vital connections in order to compensate for reduced performance under extreme conditions.

Valves are typically pressure rated by style; however size, material type, and temperature play significant roles in determining the pressure capabilities of a specific valve. Since they are often constructed of more than one material

type, it is important to review the pressure-temperature relationship. General pressure ratings are given assuming an ambient operating temperature of 73°F (23°C), above which the maximum pressure capability decreases. To account for this, detailed pressure-temperature graphs are included in this manual for each valve type.

### Flow rate

An important consideration in valve selection is the intended flow rate of the system. The flow rate of a particular valve is expressed as a CV coefficient. This value represents the number of gallons per minute (GPM) that will flow through a fully open valve with a 1psi pressure drop at 68°F (20°C). These values are determined from an industry standard testing procedure which uses water as the flowing media (specific gravity of 1.0). Tables showing acceptable flow rates for different size valves are included in this manual for each valve type.

### Vacuum Service

Many of our valves have been tested to determine their ability to withstand service under vacuum conditions. Our ball, butterfly, and diaphragm valves have been tested to hold a vacuum in excess of 29 inches of mercury. Please contact the IPEX technical services department for specific vacuum service applications.

### Other Considerations

Occasionally it may be important to select a particular valve based on spatial constraints or weight limitations. Some compact light weight valves are better suited to applications where space is limited and/or pipe support is not possible. Requirements such as automation or remote operation may also demand the selection of a particular valve. For details regarding actuated ball and butterfly valves, please refer to the IPEX Industrial technical manual entitled "Quarter Turn Automation".



## FURTHER INFORMATION

### System Design

The necessity and selection of valves for use in a piping system is largely a function of the overall process requirements. For detailed information regarding the design process and associated considerations, please refer to the IPEX Industrial technical manual entitled "Vinyl Process Piping Systems".

### Installation Considerations

For detailed information regarding piping installation and associated considerations, please refer to the IPEX Industrial technical manual entitled "Vinyl Process Piping Systems". For particular valve installation instructions, please refer to the specific valve type section in this manual.

### Testing and Operating

The purpose of system testing is to assess the quality of all joints and fittings to ensure that they will withstand the design working pressure, plus a safety margin, without loss of pressure or fluid. Typically, the system will be tested and assessed in sub-sections as this allows for improved isolation and remediation of potential problems. With this in mind, the testing of a specific installed valve is achieved while carrying out a test of the overall system.

An onsite pressure test procedure is outlined in the IPEX Industrial technical manual entitled "Vinyl Process Piping Systems" under the section entitled, "Testing". The use of this procedure should be sufficient to assess the quality of a valve installation. **In any test or operating condition, it is important to never exceed the pressure rating of the lowest rated appurtenance in the system.**

### Important points

- Never test thermoplastic piping systems with compressed air or other gases including air-over-water boosters.
- When testing, do not exceed the rated maximum operating pressure of the valve.
- Avoid the rapid closure of valves to eliminate the possibility of water hammer which may cause damage to the pipeline or the valve.

There are certain applications where proper standard procedure for valve selection may still result in operating problems. For example, when conveying volatile liquids such as hydrogen peroxide (H<sub>2</sub>O<sub>2</sub>) and sodium hypochlorite (NaClO) through ball valves, these liquids may vaporize causing a potentially dangerous pressure increase in the dead space between the ball and the valve body. If left unchecked, this pressure buildup can result in catastrophic failure of the valve. IPEX offers specially modified ball valves for these types of critical applications.

### Maintenance

IPEX valves are designed and manufactured to high quality standards with long service life expectancy. However, if maintenance is required, please refer to the specific valve type section in this manual for instructions.

## SECTION TWO: BALL VALVES

### VKD SERIES BALL VALVES

IPEX VKD Series Ball Valves offer a variety of advanced features such as the patented seat stop carrier, a high quality stem and ball support system, and a multifunctional locking handle. Deep grooves, thick o-rings, and cushioned Teflon® seats contribute to strong seals at pressures up to 232psi while an integral ISO mounting flange and support bracketing combine for simple actuation and anchoring. VKD Series Ball Valves are part of our complete Xirtec®140, Corzan®, SFPP and Duraplus® systems of pipe, valves, and fittings, engineered and manufactured to our strict quality, performance, and dimensional standards.

#### Valve Availability

Body Material:	PVC, CPVC, PP, ABS
Size Range:	1/2" through 4"
Pressure:	232psi 150psi (PP)
Seats:	Teflon® (PTFE)
Seals:	EPDM or Viton® (FPM)
End Connections:	Socket (IPS) Threaded (FNPT) Socket (Metric)



ASTM D1784  
ASTM D2464  
ASTM D2466  
ASTM D2467  
ASTM D4101  
ASTM F437  
ASTM F439  
ASTM F1498



ANSI B1.20.1



ISO 11922-1



## VKD SERIES BALL VALVES

### Sample Specification

#### 1.0 Ball Valves - VKD

##### 1.1 Material

- The valve body, stem, ball and unions shall be made of PVC compound which shall meet or exceed the requirements of cell classification 12454 according to ASTM D1784.
- or The valve body, stem, ball and unions shall be made of Corzan® CPVC compound which shall meet or exceed the requirements of cell classification 23447 according to ASTM D1784.
- or The valve body, stem, ball and unions shall be made of stabilized PP homopolymer compound, also containing a RAL 7032 pigment, which shall meet or exceed the requirements of Type I Polypropylene according to ASTM D4101.
- or The valve body, stem, ball and unions shall be made of Duraplus® ABS compound which shall meet or exceed the requirements of cell classification 43234 according to ASTM D3965.

##### 1.2 Seats

- The ball seats shall be made of Teflon® (PTFE).

##### 1.3 Seals

- The o-ring seals shall be made of EPDM.
- or The o-ring seals shall be made of Viton® (FPM).

1.4 All wetted parts of the valves shall comply with standards that are equivalent to NSF Standard 61 for potable water.

#### 2.0 Connections

##### 2.1 Socket style

- The IPS socket PVC end connectors shall conform to the dimensional standards ASTM D2466 and ASTM D2467.
- or The IPS socket CPVC end connectors shall conform to the dimensional standard ASTM F439.
- or The Metric socket PP end connectors shall conform to the dimensional standard ISO 11922-1.

##### 2.2 Threaded style

- The female NPT threaded PVC end connectors shall conform to the dimensional standards ASTM D2464, ASTM F1498, and ANSI B1.20.1.
- or The female NPT threaded CPVC end connectors shall conform to the dimensional standards ASTM F437, ASTM F1498, and ANSI B1.20.1.
- or The female NPT threaded PP end connectors shall conform to the dimensional standards ASTM F1498, and ANSI B1.20.1.

##### 3.0 Design Features

- The valve shall be double blocking with union ends.
- All valves shall be full port.
- All valves shall allow for bi-directional flow.
- The valve body shall be single end entry with a threaded carrier (ball seat support).
- The threaded carrier shall be adjustable with the valve installed.
- The valve body shall have an expansion and contraction compensating groove on the molded end.
- The valve body, union nuts, and carrier shall have deep square style threads for increased strength.
- The ball and stem shall be machined smooth to minimize wear on valve seats and seals.
- All valve seats shall have o-ring backing cushions to compensate for wear and prevent seizure of the ball.
- The stem design shall feature double o-ring seals as well as a safety shear point above the o-rings.
- All valves shall have integrally molded mounting features for actuation.
- All valves shall have integrally molded support bracketing for anchoring.
- The valve shall include the Dual Block® union nut locking mechanism.

##### 3.1 Pressure Tested

- All valves shall have been pressure tested in both the open and closed positions by the manufacturer.

##### 3.2 Pressure Rating

- All PVC, CPVC and ABS valves shall be rated at 232psi at 73°F (23°C).
- All PP valves shall be rated at 150psi at 73°F (23°C).

##### 3.3 Markings

- All valves shall be marked to indicate size, material designation, and manufacturers name or trade mark.

##### 3.4 Color Coding

- All PVC valves shall be color-coded dark gray.
- or All CPVC valves shall be color-coded light gray.
- or All PP valves shall be color-coded beige gray.
- or All ABS valves shall be color-coded light gray.

4.0 All valves shall be Xirtec®140, Corzan®, SFPP or Duraplus® by IPEX or approved equal.

## VKD SERIES BALL VALVES

### Dimensions

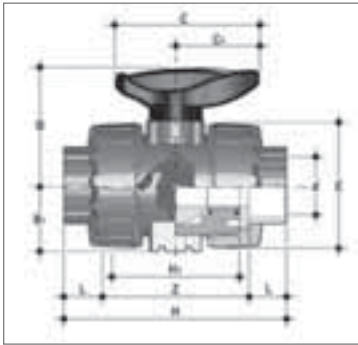

Sizes 1/2" to 2"

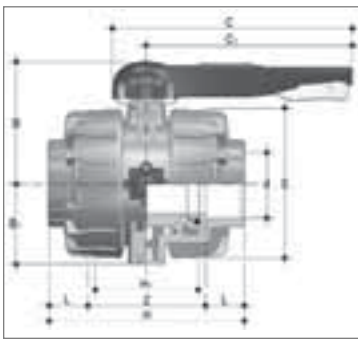

Sizes 2-1/2" to 4"

IPS Socket Connections - Dimension (inches)										
Size	d	H	L	Z	H1	E	B1	B	C1	C
1/2	0.84	4.61	0.89	2.83	2.56	2.13	1.14	2.13	1.57	2.64
3/4	1.05	5.08	1.00	3.07	2.76	2.56	1.36	2.56	1.93	3.35
1	1.32	5.59	1.13	3.33	3.07	2.87	1.54	2.74	1.93	3.35
1-1/4	1.66	6.38	1.26	3.86	3.46	3.39	1.81	3.25	2.52	4.25
1-1/2	1.90	6.77	1.38	4.02	3.66	3.86	2.05	3.50	2.52	4.25
2	2.38	7.83	1.50	4.83	4.37	4.80	2.44	4.25	2.99	5.28
2-1/2	2.88	9.25	1.75	5.75	5.24	6.46	3.43	6.46	6.89	8.86
3	3.50	10.63	1.89	6.85	5.87	7.99	4.13	6.97	10.71	12.87
4	4.50	12.13	2.26	7.60	6.57	9.37	5.08	7.68	12.99	15.16

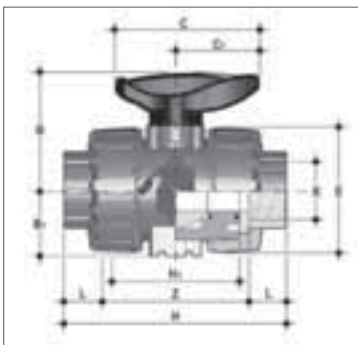

Sizes 1/2" to 2"

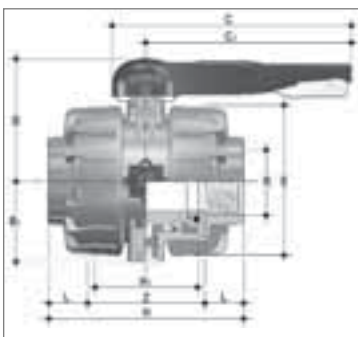

Sizes 2-1/2" to 4"

Female NPT Threaded Connections - Dimension (inches)										
Size	R	H	L	Z	H1	E	B1	B	C1	C
1/2	1/2-NPT	4.37	0.70	2.97	2.56	2.13	1.14	2.13	1.57	2.64
3/4	3/4-NPT	4.61	0.71	3.19	2.76	2.56	1.36	2.56	1.93	3.35
1	1-NPT	5.31	0.89	3.54	3.07	2.87	1.54	2.74	1.93	3.35
1-1/4	1-1/4-NPT	6.02	0.99	4.05	3.46	3.39	1.81	3.25	2.52	4.25
1-1/2	1-1/2-NPT	6.14	0.97	4.20	3.66	3.86	2.05	3.50	2.52	4.25
2	2-NPT	7.32	1.17	4.99	4.37	4.80	2.44	4.25	2.99	5.28
2-1/2	2-1/2-NPT	9.25	1.31	6.64	5.24	6.46	3.43	6.46	6.89	8.86
3	3-NPT	10.63	1.40	7.83	5.87	7.99	4.13	6.97	10.71	12.87
4	4-NPT	12.13	1.48	9.17	6.57	9.37	5.08	7.68	12.99	15.16

## VKD SERIES BALL VALVES

### Dimensions

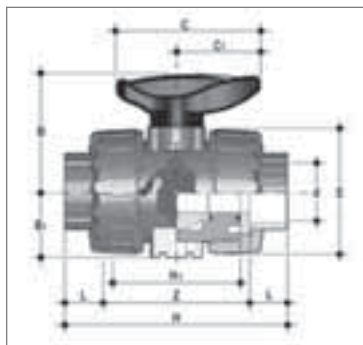

Sizes 20mm to 63mm

Metric Socket Connections - Dimension (inches)										
Size	d	H	L	Z	H1	E	B1	B	C1	C
20mm	0.79	4.02	0.57	2.87	2.56	2.13	1.14	2.13	1.57	2.64
25mm	0.98	4.49	0.63	3.23	2.76	2.56	1.36	2.56	1.93	3.35
32mm	1.26	4.96	0.71	3.54	3.07	2.87	1.54	2.74	1.93	3.35
40mm	1.57	5.55	0.81	3.94	3.35	3.39	1.81	3.25	2.52	4.25
50mm	1.97	6.46	0.93	4.61	3.66	3.86	2.05	3.50	2.52	4.25
63mm	2.48	7.83	1.08	5.67	4.37	4.80	2.44	4.25	2.99	5.28

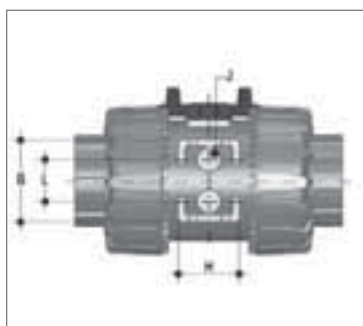

Sizes 1/2" to 2"

Support Bracket - Dimension (inches)				
Size	J	B	L	H
1/2	M4	1.24	0.79	1.06
3/4	M4	1.57	0.79	1.18
1	M4	1.57	0.79	1.18
1-1/4	M6	1.97	1.18	1.38
1-1/2	M6	1.97	1.18	1.38
2"	M6	2.36	1.18	1.57

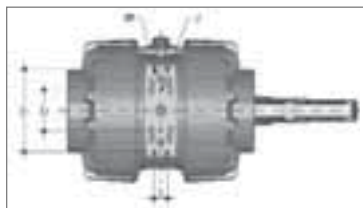

Sizes 2-1/2" to 4"

Support Bracket - Dimension (inches)					
Size	J	f	l	l1	l2
2-1/2	M6	0.25	0.69	3.54	2.04
3	M8	0.33	0.83	4.43	2.48
4	M8	0.33	0.83	5.39	2.64

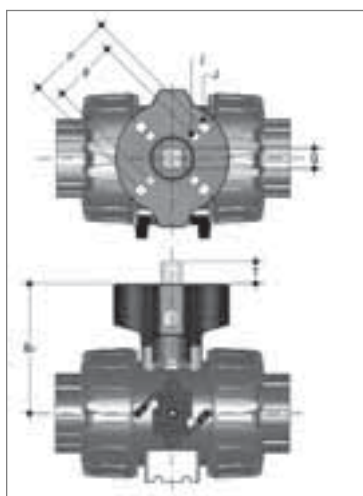

Sizes 1/2" to 2"

Actuation Pad - Dimension (inches)							
Size	B2	p	P	j	J	T	Q
1/2	2.28	F03	F04	0.22	0.22	0.47	0.43
3/4	2.89	F03	F05	0.22	0.26	0.47	0.43
*3/4	2.89	F04		0.22		0.47	0.43
1	2.91	F03	F05	0.22	0.26	0.47	0.43
*1	2.91	F04		0.22		0.43	0.43
1-1/4	3.82	F05	F07	0.26	0.33	0.63	0.55
1-1/2	4.09	F05	F07	0.26	0.33	0.63	0.55
2	4.49	F05	F07	0.26	0.33	0.63	0.55

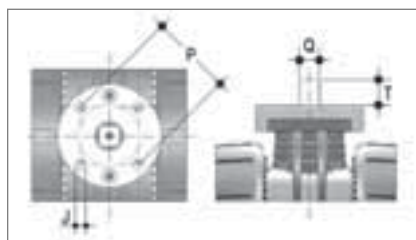

Sizes 2-1/2" to 4"

Actuation Pad - Dimension (inches)				
Size	P	J	T	Q
2-1/2	F07	0.35	0.63	0.55
3	F07	0.35	0.63	0.55
4	F07	0.35	0.75	0.67

## VKD SERIES BALL VALVES

### Weights

Size (inches)		Approximate Weight (lbs)					
IPS	Metric	IPS / Metric Socket			FNPT Threaded		
		PVC	CPVC	PP	PVC	CPVC	PP
1/2	20mm	0.47	0.51	0.32	0.46	0.50	0.31
3/4	25mm	0.76	0.82	0.48	0.74	0.79	0.50
1	32mm	0.99	1.06	0.66	0.99	1.06	0.67
1-1/4	40mm	1.58	1.70	1.06	1.49	1.61	1.01
1-1/2	50mm	2.15	2.31	1.50	2.11	2.26	1.43
2	63mm	3.77	4.06	2.57	3.68	3.95	2.50
2-1/2	-	9.68	10.50	-	9.69	10.50	-
3	-	15.90	17.30	-	16.00	17.40	-
4	-	24.40	26.90	-	24.50	27.00	-

### Flow Coefficients

Size	C <sub>v</sub>
1/2	14.0
3/4	27.0
1	53.9
1-1/4	77.0
1-1/2	123
2	238
2-1/2	368
3	497
4	665

BALL VALVES

### Pressure – Temperature Ratings

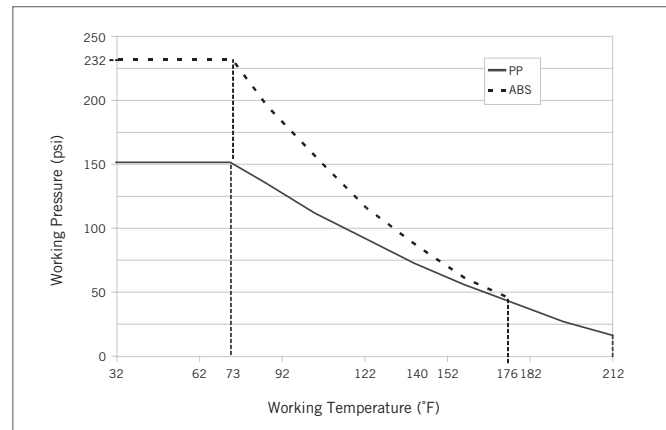
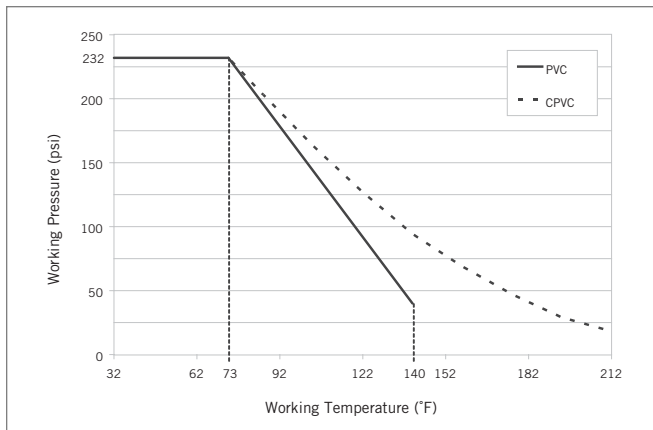

### Pressure Loss Chart

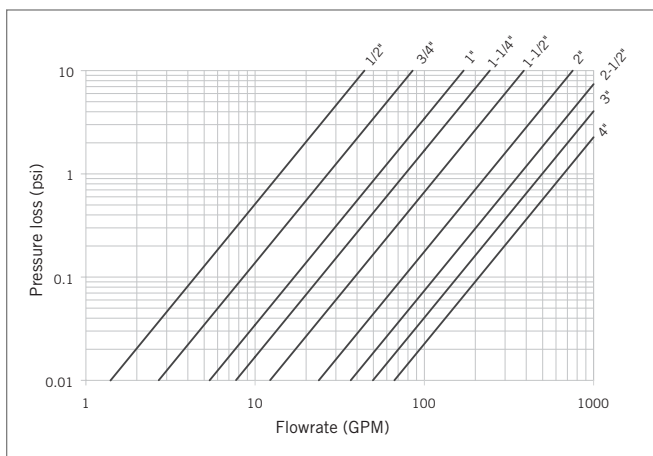

## VKD SERIES BALL VALVES

### Components

Sizes 1/2" to 2"

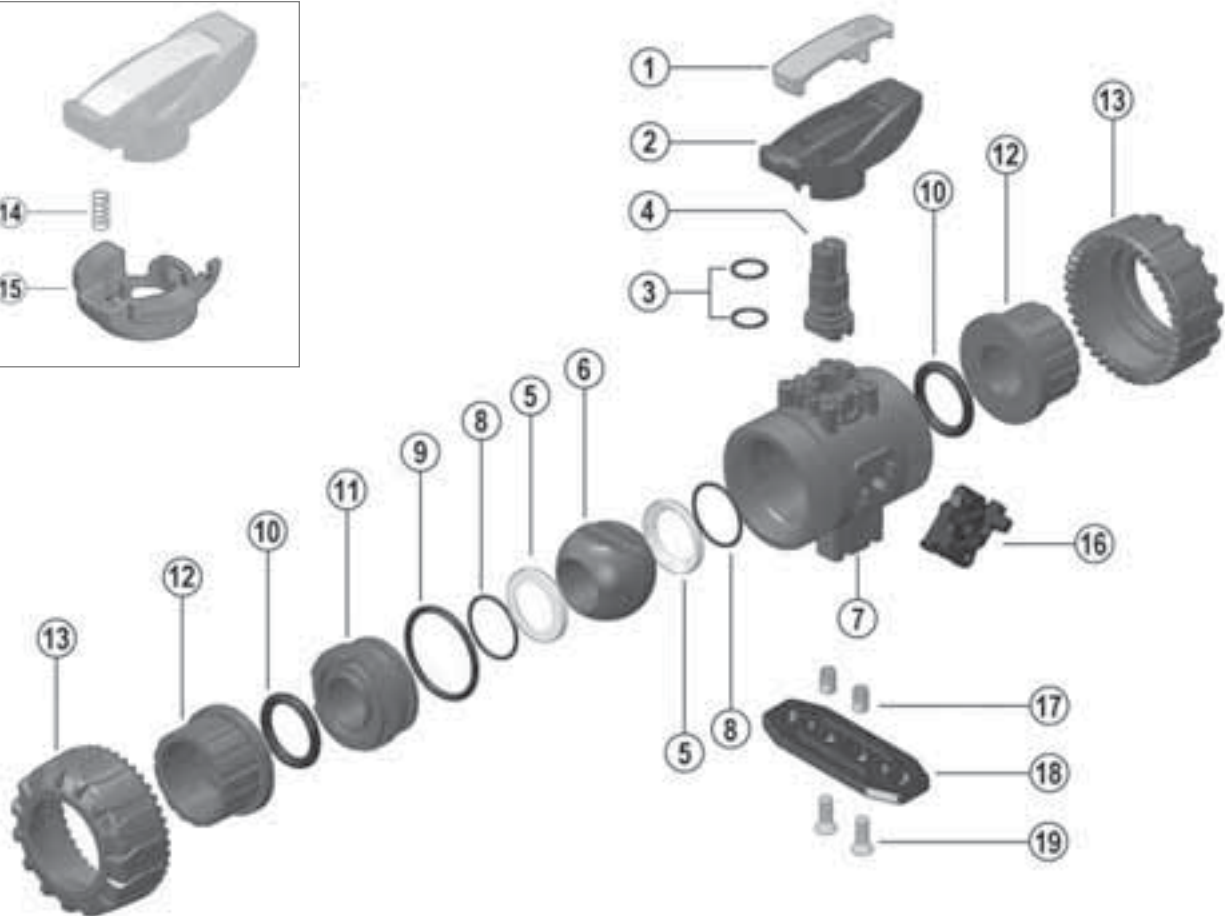

#	Component	Material	Qty
1	insert	PVC / CPVC / PP / ABS	1
2	handle	PVC / CPVC / PP / ABS	1
3	stem o-ring	EPDM / Viton®	2
4	stem	PVC / CPVC / PP / ABS	1
5	ball seat	PTFE	2
6	ball	PVC / CPVC / PP / ABS	1
7	body	PVC / CPVC / PP / ABS	1
8	ball seat o-ring	EPDM / Viton®	2
9	body o-ring	EPDM / Viton®	1
10	socket o-ring	EPDM / Viton®	2

#	Component	Material	Qty
11	carrier	PVC / CPVC / PP / ABS	1
12	end connector	PVC / CPVC / PP / ABS	2
13	union nut	PVC / CPVC / PP / ABS	2
14*	spring	SS	1
15*	handle lock	GRPP	1
16	DUAL BLOCK®	POM	1
17*	bracket bushing	SS / brass	2
18*	mounting plate	GRPP	1
19*	screw	SS	2

\*Accessories

## VKD SERIES BALL VALVES

### Components (cont'd)

Sizes 2-1/2" to 4"

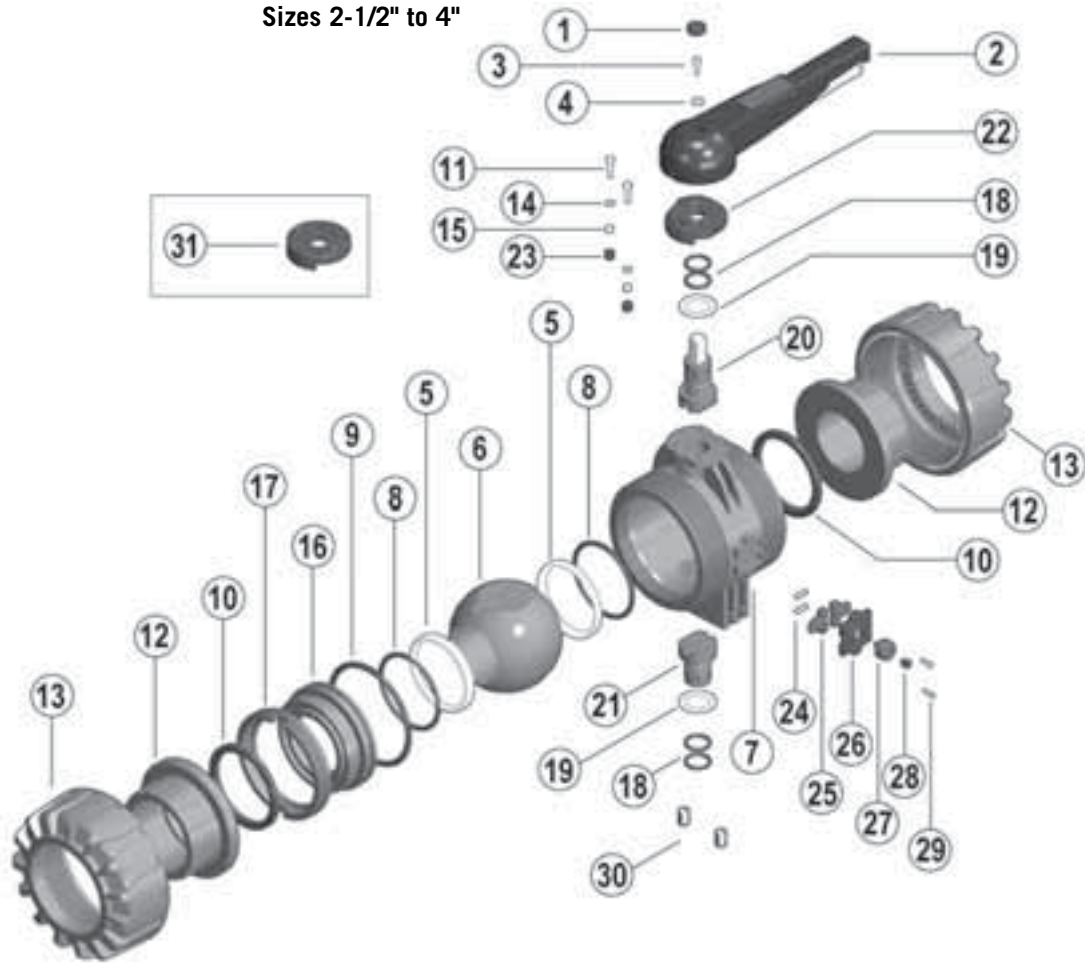

#	Component	Material	Qty
1	protective cap	PE	1
2	handle	PVC	1
3	bolt	SS	1
4	washer	SS	1
5	ball seat	PTFE	2
6	ball	PVC / CPVC	1
7	body	PVC / CPVC	1
8	ball seat o-ring	EPDM / Viton®	2
9	body o-ring	EPDM / Viton®	1
10	socket seal	EPDM / Viton®	2
11	bolt	SS	2
12	end connector	PVC / CPVC	2
13	union nut	PVC / CPVC	2
14	washer	SS	2
15	nut	SS	2
16	carrier	PVC / CPVC	1

#	Component	Material	Qty
17	stop ring	PVC / CPVC	1
18	stem o-ring	EPDM / Viton®	4
19	bushing	PTFE	2
20	upper stem	PVC / CPVC & SS	1
21	lower stem	PVC / CPVC	1
22	pad	GRPP	1
23	protective cap	PE	2
24	spring	SS	2
25	nut block	GRPP	2
26	cover	PP	1
27	nut block button	GRPP	1
28	protective cap	PE	1
29	screw	nylon	2
30	bracket bushing	brass	2
31	actuation pad	GRPP	1

## VKD SERIES BALL VALVES

### Installation Procedures

1. Remove the union nuts (part #13 on previous page) and slide them onto the pipe.
2. Please refer to the appropriate connection style sub-section:
  - a. For socket style, solvent cement or fuse the end connectors (12) onto the pipe ends. For correct solvent cementing procedure, please refer to the section entitled, *"Joining Methods - Solvent Cementing"* in the IPEX Industrial Technical Manual Series, *"Volume I: Vinyl Process Piping Systems"*. **Be sure to allow sufficient cure time before continuing with the valve installation.**
  - b. For threaded style, thread the end connectors (12) onto the pipe ends. For correct joining procedure, please refer to the section entitled, *"Joining Methods - Threading"* in the IPEX Industrial Technical Manual Series, *"Volume I: Vinyl Process Piping Systems"*.
3. Open and close the valve to ensure that the carrier (11 or 16) is at the desired adjustment. If adjustment is required, ensure that the valve is in the closed position then remove the insert tool (1) from the handle (2). For sizes 2-1/2" to 4", use the tool that accompanies the valve. Line up the moldings on the tool with the slots in the carrier. Tighten or loosen to the desired position then replace the tool on the handle.
4. Ensure that the valve is in the closed position, and that the socket o-rings (10) are properly fitted in their grooves. If anchoring is required, insert the bracket bushings (17) into the bottom of the valve (sizes 1/2" to 2" only). Carefully place the valve in the system between the two end connections and fix if necessary.
5. Tighten the union nut on the side opposite to that which is marked "ADJUST". Hand tightening is typically sufficient to maintain a seal for the maximum working pressure. Over-tightening may damage the threads on the valve body and/or the union nut, and may even cause the union nut to crack.
6. Tighten the union nut on the side marked "ADJUST". Tightening the union nuts in this order results in the best possible valve performance due to optimum positioning and sealing of the ball and seat support system.
7. Open and close the valve to again ensure that the cycling performance is adequate. If adjustment is required, place the valve in the closed position, loosen the union nuts, remove the valve from the system, and then continue from Step 3.
8. Engage the Dual Block® system by affixing the molded piece (16, sizes 1/2" to 2") to the side of the valve body or by turning the red knob (27, sizes 2-1/2" to 4") to the locked position. This feature will prevent back-off of the union nuts during operation.



**2-1/2" - 4" Dual Block® Mechanism**



**1/2" - 2" Dual Block® Mechanism**

## VKD SERIES BALL VALVES

### Valve Maintenance

#### Disassembly

1. If removing the valve from an operating system, isolate the valve from the rest of the line. **Be sure to depressurize and drain the valve and isolated branch.**
2. If necessary, detach the valve from the support structure by disassembling the connections to the bracket on the optional bottom of the valve body (7).
3. Unlock the Dual Block® system by compressing the two ends of the molded piece (16, sizes 1/2" to 2") or by turning the red knob (27, sizes 2-1/2" to 4") to the unlocked position. Loosen both union nuts (13) and drop the valve out of the line. If retaining the socket o-rings (10), take care that they are not lost when removing the valve from the line.
4. Place the valve in the open position then line up the moldings on the wrench tool (1, sizes 1/2" to 2") with the slots in the carrier (found on the side marked "ADJUST"). Loosen and remove the carrier (11 or 16).
5. Carefully press the ball (6) out of the valve body, taking care not to score or damage the outer surface.
6. Remove the handle (2) by pulling upwards (sizes 1/2" to 2") or by removing the protective cap (1), bolt (3) and washer (4) (sizes 2-1/2" to 4").
7. On sizes 2-1/2" to 4", remove the throttling pad (22) by loosening and removing the bolts (11), washers (14), nuts (15), and caps (23).
8. Press the stem (4 or 20) into the valve body from above. On sizes 2-1/2" to 4", remove the lower stem (21) by pushing it into the valve body from below.
9. The stem o-rings (3 or 18), body o-ring (9), ball seats (5), ball seat o-rings (8), and bushings (19, sizes 2-1/2" to 4") can now be removed and/or replaced.

**Note:** It is not typically necessary to disassemble the Dual Block® components (sizes 2-1/2" to 4").

#### Operating Notes

The VKD handle incorporates a locking mechanism that prevents unintentional rotation. When engaged, the spring-loaded handle release is locked and the valve cannot be cycled. A padlock can be installed through this portion of the handle as an additional safety precaution.

#### Sizes 2-1/2"



#### Assembly

**Note:** Before assembling the valve components, it is advisable to lubricate the o-rings with a water soluble lubricant. **Be sure to consult the "IPEX Chemical Resistance Guide" and/or other trusted resources to determine specific lubricant-rubber compatibilities.**

1. Replace the stem o-rings (3 or 18), body o-ring (9), ball seat o-rings (8), ball seats (5), and bushings (19, sizes 2-1/2" to 4") in their proper positions.
2. Insert the stem (4 or 20) into position from inside the valve body (7). On sizes 2-1/2" to 4", insert the lower stem (21) as well.
3. On sizes 2-1/2" to 4", replace the throttling pad (22) and affix in position using the bolts (11), washers (14), and nuts (15). Replace the caps (23) over the nuts.
4. Replace the handle (2). On sizes 2-1/2" to 4", affix using the bolt (3) and washer (4), then replace the protective cap (1).
5. Carefully insert the ball (6) into the valve body, taking care not to score or damage the outer surface. Ensure that the valve handle and ball position correspond to the same operating position.
6. Insert the threaded carrier (11 or 16) and tighten into the valve body. Use the wrench tool to sufficiently tighten.
7. Place the end connectors (12) into the union nuts (13), then thread onto the valve body taking care that the socket o-rings remain properly fitted in their grooves.
8. Engage the Dual Block® system by affixing the molded piece (16, sizes 1/2" to 2") to the side of the valve body or by turning the red knob (27, sizes 2-1/2" to 4") to the locked position.



#### Sizes 3" & 4"



## VX SERIES BALL VALVES

IPEX VX Series Ball Valves are ideal for general purpose and O.E.M. applications. These valves feature an ultra-compact double block design, and full port bi-directional operation. The true union design allows the valve to be easily removed from the piping system and fully serviced. A threaded seat stop carrier provides improved seal integrity under tough service conditions while the removable handle also functions as a tool for ball seat adjustment. VX Series Ball Valves are part of our complete Xirtec®140 and Corzan® systems of pipe, valves, and fittings, engineered and manufactured to our strict quality, performance, and dimensional standards.

### Valve Availability

Body Material:	PVC, CPVC
Size Range:	1/2" through 6"
Pressure:	232psi (1/2" to 2") 150psi (2-1/2" to 6")
Seats:	Teflon® (PTFE)
Seals:	EPDM or Viton® (FPM)
End Connections:	Socket (IPS) Threaded (FNPT) Flanged (ANSI 150)



ASTM D1784  
ASTM D2464  
ASTM D2466  
ASTM D2467  
ASTM F437  
ASTM F439  
ASTM F1498



ANSI B1.20.1  
ANSI B16.5



## VX SERIES BALL VALVES

### Sample Specification

#### 1.0 Ball Valves - VX

##### 1.1 Material

- The valve body, stem, ball and unions shall be made of PVC compound which shall meet or exceed the requirements of cell classification 12454 according to ASTM D1784.
- or The valve body, stem, ball and unions shall be made of Corzan® CPVC compound which shall meet or exceed the requirements of cell classification 23447 according to ASTM D1784.

##### 1.2 Seats

- The ball seats shall be made of Teflon® (PTFE).

##### 1.3 Seals

- The o-ring seals shall be made of EPDM.
- or The o-ring seals shall be made of Viton® (FPM).

- 1.4** All wetted parts of the valves shall comply with standards that are equivalent to NSF Standard 61 for potable water.

#### 2.0 Connections

##### 2.1 Socket style

- The IPS socket PVC end connectors shall conform to the dimensional standards ASTM D2466 and ASTM D2467.
- or The IPS socket CPVC end connectors shall conform to the dimensional standard ASTM F439.

##### 2.2 Threaded style

- The female NPT threaded PVC end connectors shall conform to the dimensional standards ASTM D2464, ASTM F1498, and ANSI B1.20.1.
- or The female NPT threaded CPVC end connectors shall conform to the dimensional standards ASTM F437, ASTM F1498, and ANSI B1.20.1.

##### 2.3 Flanged style

- The ANSI 150 flanged PVC end connectors shall conform to the dimensional standard ANSI B16.5.
- or The ANSI 150 flanged CPVC end connectors shall conform to the dimensional standard ANSI B16.5.

#### 3.0 Design Features

- The valve shall be double blocking with union ends.
- All sizes ½" through 4" shall be full port.
- All sizes shall allow for bi-directional flow.
- The valve body shall be single end entry with a threaded carrier (ball seat support).

#### 3.0 Design Features

- The valve body shall have an expansion and contraction compensating groove on the molded end.
- The valve body, union nuts, and carrier shall have deep square style threads for increased strength.
- The ball shall be machined smooth to minimize wear on valve seats.
- The stem design shall feature a shear point above the o-ring to maintain system integrity in the unlikely event of a stem breakage.
- The handle shall incorporate a tool for adjustment of the threaded carrier.
- The handle shall be reversible to allow for operation in tight places.

#### 3.1 Pressure Tested

- All valves shall have been pressure tested in both the open and closed positions by the manufacturer.

#### 3.2 Pressure Rating

- Valve sizes ½" through 2" shall be rated at 232psi at 73°F (23°C).
- Valve sizes 2½" through 6" shall be rated at 150psi at 73°F (23°C).
- All sizes of flanged valves shall be rated at 150psi at 73°F (23°C).

#### 3.3 Markings

- All valves shall be marked to indicate size, material designation, and manufacturers name or trade mark.

#### 3.4 Color Coding

- All PVC valves shall be color-coded dark gray.
- or All CPVC valves shall be color-coded light gray.

- 4.0** All valves shall be Xirtec® 140 or Corzan® by IPEX or approved equal.

## VX SERIES BALL VALVES

### Dimensions

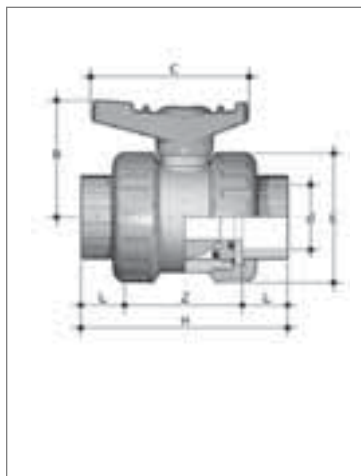

IPS Socket Connections - Dimension (inches)							
Size	d	L	Z	H	E	B	C
1/2	0.84	0.89	2.01	3.78	2.09	1.97	2.56
3/4	1.05	1.00	2.13	4.13	2.44	2.28	2.99
1	1.32	1.13	2.34	4.61	2.80	2.56	3.35
1-1/4	1.66	1.26	2.83	5.35	3.31	2.99	3.94
1-1/2	1.90	1.38	3.03	5.79	3.86	3.35	4.41
2	2.38	1.50	3.84	6.85	4.61	4.06	5.39
2-1/2	2.88	1.75	5.00	8.50	6.06	5.24	8.74
3	3.50	1.89	5.47	9.25	7.44	6.06	10.63
4	4.50	2.26	7.64	12.17	8.70	6.89	10.63
*6	6.63	3.03	19.59	25.65	8.70	6.89	10.63

\*The 6" valve is a 4" with venturied ends.

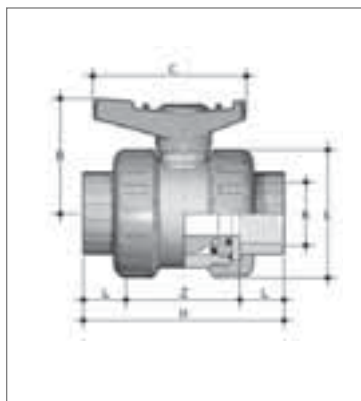

Female NPT Threaded Connections - Dimension (inches)							
Size	R	L	Z	H	E	B	C
1/2	1/2-NPT	0.70	2.14	3.54	2.09	1.97	2.56
3/4	3/4-NPT	0.71	2.24	3.66	2.44	2.28	2.99
1	1-NPT	0.89	2.55	4.33	2.80	2.56	3.35
1-1/4	1-1/4-NPT	0.99	3.02	5.00	3.31	2.99	3.94
1-1/2	1-1/2-NPT	0.97	3.21	5.16	3.86	3.35	4.41
2	2-NPT	1.17	4.01	6.34	4.61	4.06	5.39
3	3-NPT	1.40	6.81	9.61	7.44	6.06	10.63
4	4-NPT	1.48	9.20	12.17	8.70	6.89	10.63

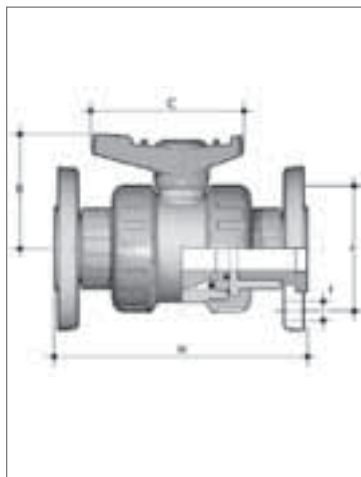

ANSI 150 Flanged (Vanstone) Connections - Dimension (inches)						
Size	# holes	f	F	H	B	C
1/2	4	5/8	2-3/8	5.59	1.97	2.56
3/4	4	5/8	2-3/4	6.07	2.28	2.99
1	4	5/8	3-1/8	6.74	2.56	3.35
1-1/4	4	5/8	3-1/2	7.54	2.99	3.94
1-1/2	4	5/8	3-7/8	8.29	3.35	4.41
2	4	3/4	4-3/4	9.60	4.06	5.39
2-1/2	4	3/4	5-1/2	11.13	5.24	8.74
3	4	3/4	6	11.74	6.06	10.63
4	8	3/4	7-1/2	14.99	6.89	10.63
*6	8	7/8	9-1/2	28.55	6.89	10.63

\*The 6" valve is a 4" with venturied ends.

## VX SERIES BALL VALVES

### Weights

Size (inches)	Approximate Weight (lbs)					
	IPS Socket	PVC FNPT Threaded	ANSI Flanged	IPS Socket	CPVC FNPT Threaded	ANSI Flanged
1/2	0.32	0.32	0.72	0.34	0.34	0.76
3/4	0.49	0.49	1.07	0.53	0.53	1.13
1	0.69	0.69	1.48	0.76	0.76	1.58
1-1/4	1.11	1.11	2.11	1.22	1.22	2.22
1-1/2	1.60	1.60	2.80	1.75	1.75	3.02
2	2.74	2.74	4.62	3.02	3.02	5.02
2-1/2	5.73	N/A	8.31	6.27	N/A	9.35
3	9.55	9.55	13.29	10.45	10.45	14.40
4	16.42	16.42	22.42	17.97	17.97	24.30
*6	25.02	N/A	35.04	27.14	N/A	37.73

\*The 6" valve is a 4" with venturied ends.

### Flow Coefficients

Size	C <sub>v</sub>
1/2	14.0
3/4	27.0
1	53.9
1-1/4	77.0
1-1/2	123
2	238
2-1/2	368
3	497
4	665
6	665*

\*Not including venturied ends.

### Pressure – Temperature Ratings

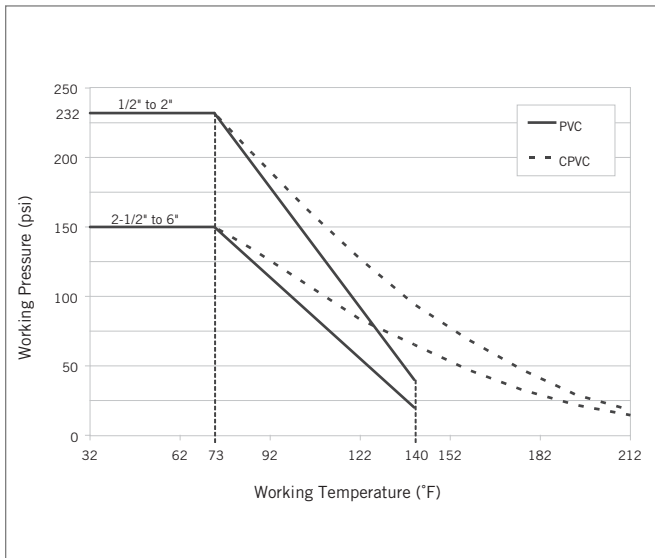

### Pressure Loss Chart

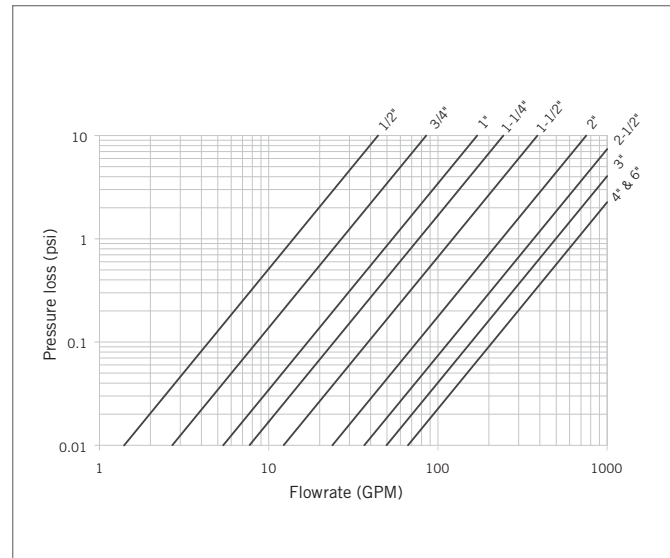

## VX SERIES BALL VALVES

### Components

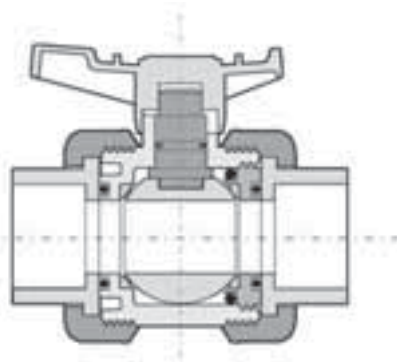
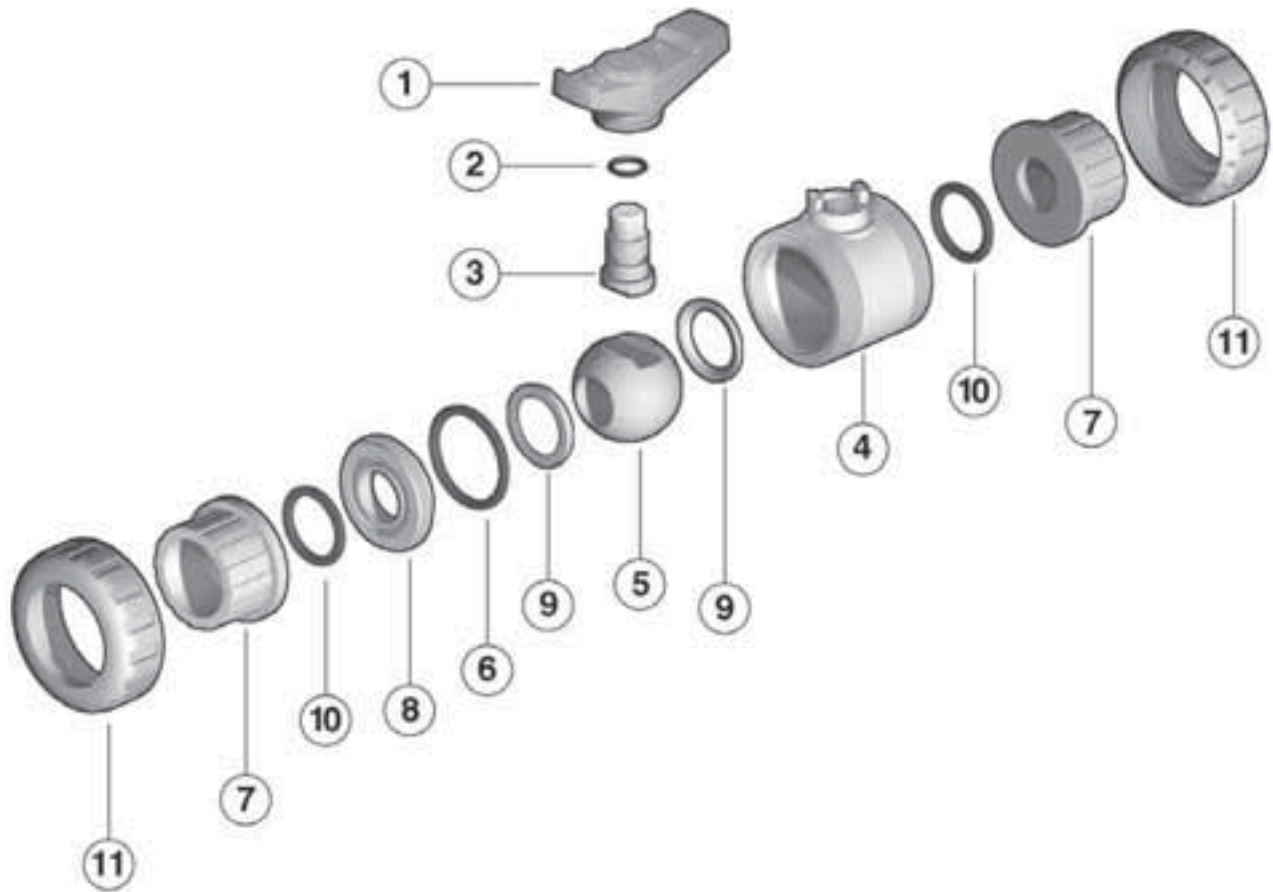

#	Component	Material	Qty
1*	handle	High Impact PVC	1
2*	stem o-ring	EPDM or Viton®	1
3*	stem	PVC / CPVC	1
4	body	PVC / CPVC	1
5	ball	PVC / CPVC	1
6*	body o-ring	EPDM or Viton®	1
7*	end connector	PVC / CPVC	2
8	support for ball seat	PVC / CPVC	1
9*	ball seat	PTFE	2
10*	socket o-ring	EPDM or Viton®	2
11*	union nut	PVC / CPVC	2

\* Spare parts available.

## VX SERIES BALL VALVES

### Installation Procedures

1. For socket and threaded style connections, remove the union nuts (part #11 on previous page) and slide them onto the pipe. For flanged connections, remove the union nut / flange assemblies from the valve.
2. Please refer to the appropriate connection style sub-section:
  - a. For socket style, solvent cement the end connectors (7) onto the pipe ends. For correct joining procedure, please refer to the section entitled, *“Joining Methods – Solvent Cementing”* in the IPEX Industrial Technical Manual Series, *“Volume I: Vinyl Process Piping Systems”*. **Be sure to allow sufficient cure time before continuing with the valve installation.**
  - b. For threaded style, thread the end connectors (7) onto the pipe ends. For correct joining procedure, please refer to the section entitled, *“Joining Methods – Threading”* in the IPEX Industrial Technical Manual Series, *“Volume I: Vinyl Process Piping Systems”*.
  - c. For flanged style, join the union nut / flange assemblies to the pipe flanges. For correct joining procedure, please refer to the section entitled, *“Joining Methods – Flanging”* in the IPEX Industrial Technical Manual Series, *“Volume I: Vinyl Process Piping Systems”*.
3. Open and close the valve to ensure that the ball seat support (8) is at the desired adjustment. If adjustment is required, ensure that the valve is in the closed position then remove the handle (1) from the valve stem. Line up the moldings on the handle with the slots in the ball seat support. Tighten or loosen to the desired position then replace the handle on the valve stem.
4. Ensure that the valve is in the closed position, and that the socket o-rings (10) are properly fitted in their grooves. Carefully place the valve in the system between the two end connections.
5. Tighten the union nut on the side opposite to that which is marked “ADJUST”. Hand tightening is typically sufficient to maintain a seal for the maximum working pressure. Over-tightening may damage the threads on the valve body and/or the union nut and may even cause the union nut to crack.
6. Tighten the union nut on the side marked “ADJUST”. Tightening the union nuts in this order results in the best possible valve performance due to optimum positioning and sealing of the ball and seat support system.
7. Open and close the valve to again ensure that the cycling performance is adequate. If adjustment is required, place the valve in the closed position, loosen the union nuts, remove the valve from system and then continue from Step 3.



## VX SERIES BALL VALVES

### Valve Maintenance

#### Disassembly

1. If removing the valve from an operating system, isolate the valve from the rest of the system. Be sure to depressurize and drain the isolated branch and valve before continuing.
2. Loosen both union nuts (11) and drop the valve out of the line. If retaining the socket o-rings (10), take care that they are not lost when removing the valve from the line.
3. To disassemble, place the valve in the closed position then remove the handle (1) from the valve stem.
4. Line up the moldings on the handle with the slots in the ball seat support (found on the side marked "ADJUST"). Loosen and remove the ball seat support (8) by turning in a counterclockwise direction.
5. Carefully press the ball (5) out of the valve body, taking care not to score or damage the outer surface.
6. To remove the stem (3), press it into the valve body (4) from above.
7. The stem o-ring (2), body o-ring (6), and ball seats (9) can now be removed and/or replaced.

#### Assembly

**Note:** Before assembling the valve components, it is advisable to lubricate the o-rings with a water soluble lubricant. **Be sure to consult the "IPEX Chemical Resistance Guide" and/or other trusted resources to determine specific lubricant-rubber compatibilities.**

1. Firmly place the ball seat (9) in the groove on the opposite end inside the valve body (4).
2. Properly fit the stem o-ring (2) in the groove on the stem (3), then insert the stem from the inside of the valve body.
3. Ensure that the valve stem is in the closed position then insert the ball (5) into the valve body taking care not to score or damage the outer surface.
4. Check that the ball seat (9) and body o-ring (6) are properly fitted on the ball seat support (8), then slightly hand tighten into the valve body. Line up the moldings on the handle (1) with the slots in the ball seat support then tighten by turning in a clockwise direction.
5. Replace the handle on the valve stem then cycle the valve open and closed to determine whether or not the performance is adequate. If so desired, the handle can be removed and used to make further adjustments.
6. Properly fit the socket o-rings (10) in their respective grooves.
7. Place the end connectors (7) into the union nuts (11), then thread onto the valve body taking care that the socket o-rings remain properly fitted in their grooves.



## VE SERIES BALL VALVES

IPEX VE Series Ball Valves are ideal for light industrial and water applications. These valves feature an ultra-compact double block design, and full port bi-directional operation. The true union design allows the valve to be easily removed from the piping system and fully serviced. A threaded seat stop carrier provides improved seal integrity under tough service conditions while the removable handle also functions as a tool for ball seat adjustment. VE Series Ball Valves are part of our complete Xirtec®140 systems of pipe, valves, and fittings, engineered and manufactured to our strict quality, performance, and dimensional standards.

### Valve Availability

Body Material:	PVC
Size Range:	1/2" through 2"
Pressure:	232psi
Seats:	Teflon® (PTFE) – HDPE blend
Seals:	EPDM
End Connections:	Socket (IPS) Threaded (FNPT)



ASTM D1784  
ASTM D2464  
ASTM D2466  
ASTM D2467  
ASTM F1498



ANSI B1.20.1



## VE SERIES BALL VALVES

**Sample Specification****1.0 Ball Valves - VE****1.1 Material**

- The valve body, stem, ball and unions shall be made of PVC compound which shall meet or exceed the requirements of cell classification 12454 according to ASTM D1784.

**1.2 Seats**

- The ball seats shall be made of a Teflon® (PTFE) – HDPE blend.

**1.3 Seals**

- The o-ring seals shall be made of EPDM.

- 1.4** All wetted parts of the valves shall comply with standards that are equivalent to NSF Standard 61 for potable water.

**2.0 Connections****2.1 Socket style**

- The IPS socket PVC end connectors shall conform to the dimensional standards ASTM D2466 and ASTM D2467.

**2.2 Threaded style**

- The female NPT threaded PVC end connectors shall conform to the dimensional standards ASTM D2464, ASTM F1498, and ANSI B1.20.1.

**3.0 Design Features**

- The valve shall be double blocking with union ends.
- All sizes shall be full port.
- All sizes shall allow for bi-directional flow.
- The valve body shall be single end entry with a threaded carrier (ball seat support).
- The valve body shall have an expansion and contraction compensating groove on the molded end.
- The valve body, union nuts, and carrier shall have deep square style threads for increased strength.
- The ball shall be machined smooth to minimize wear on valve seats.
- The stem design shall feature a shear point above the o-ring to maintain system integrity in the unlikely event of a stem breakage.
- The handle shall incorporate a tool for adjustment of the threaded carrier.
- The handle shall be reversible to allow for operation in tight places.

**3.1 Pressure Tested**

- All valves shall have been pressure tested in both the open and closed positions by the manufacturer.

**3.2 Pressure Rating**

- All sizes shall be rated at 232psi at 73°F (23°C).

**3.3 Markings**

- All valves shall be marked to indicate size, material designation, and manufacturers name or trade mark.

**3.4 Color Coding**

- All PVC valves shall be color-coded dark gray with a blue handle.

- 4.0** All valves shall be Xirtec® 140 by IPEX or approved equal.

## VE SERIES BALL VALVES

### Dimensions

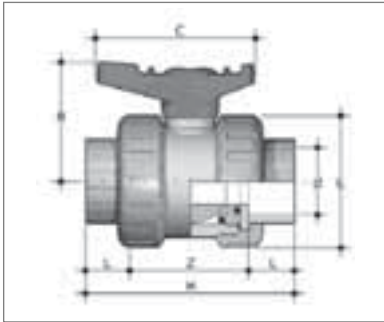

IPS Socket Connections - Dimension (inches)							
Size	d	L	Z	H	E	B	C
1/2	0.84	0.89	2.01	3.78	2.09	1.97	2.56
3/4	1.05	1.00	2.13	4.13	2.44	2.28	2.99
1	1.32	1.13	2.34	4.61	2.80	2.56	3.35
1-1/4	1.66	1.26	2.83	5.35	3.31	2.99	3.94
1-1/2	1.90	1.38	3.03	5.79	3.86	3.35	4.41
2	2.38	1.50	3.84	6.85	4.61	4.06	5.39

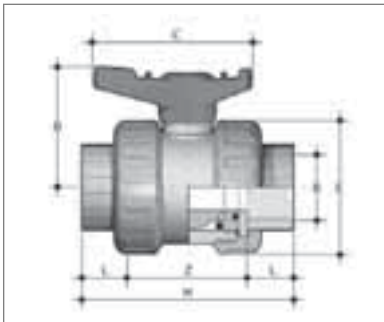

Female NPT Threaded Connections - Dimension (inches)							
Size	R	L	Z	H	E	B	C
1/2	1/2-NPT	0.70	2.14	3.54	2.09	1.97	2.56
3/4	3/4-NPT	0.71	2.24	3.66	2.44	2.28	2.99
1	1-NPT	0.89	2.55	4.33	2.80	2.56	3.35
1-1/4	1-1/4-NPT	0.99	3.02	5.00	3.31	2.99	3.94
1-1/2	1-1/2-NPT	0.97	3.21	5.16	3.86	3.35	4.41
2	2-NPT	1.17	4.01	6.34	4.61	4.06	5.39

### Weights

Size (inches)	Approximate Weight (lbs)	
	PVC	
	IPS Socket	FNPT Threaded
1/2	0.32	0.32
3/4	0.49	0.49
1	0.69	0.69
1-1/4	1.11	1.11
1-1/2	1.60	1.60
2	2.74	2.74

### Flow Coefficients

Size	C <sub>v</sub>
1/2	14.0
3/4	27.0
1	53.9
1-1/4	77.0
1-1/2	123
2	238

### Pressure – Temperature Ratings

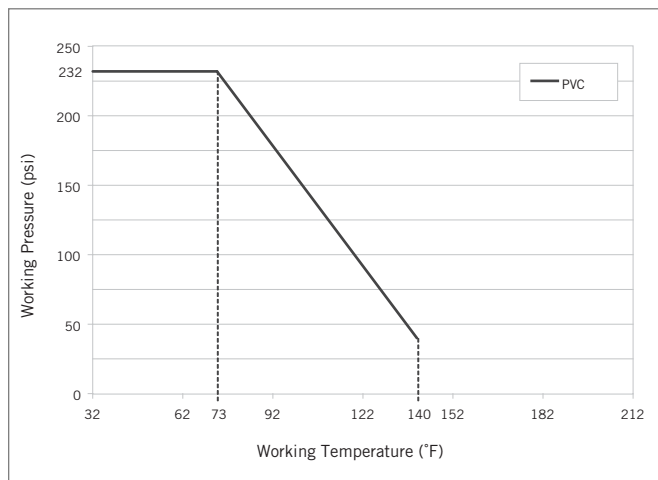

### Pressure Loss Chart

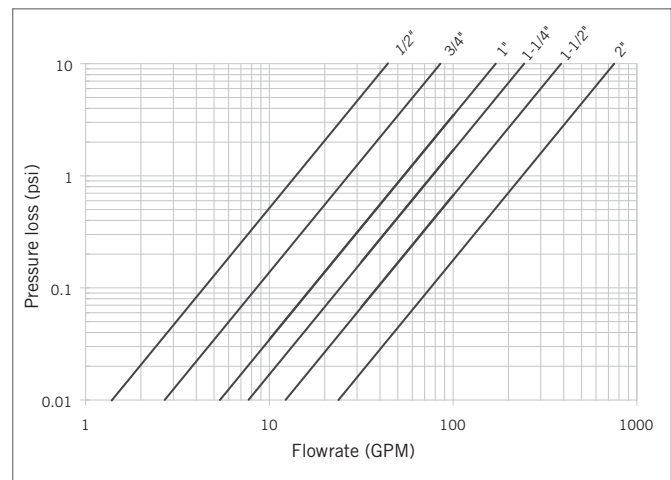

## VE SERIES BALL VALVES

### Components

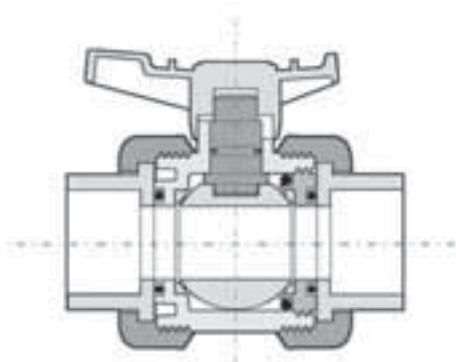
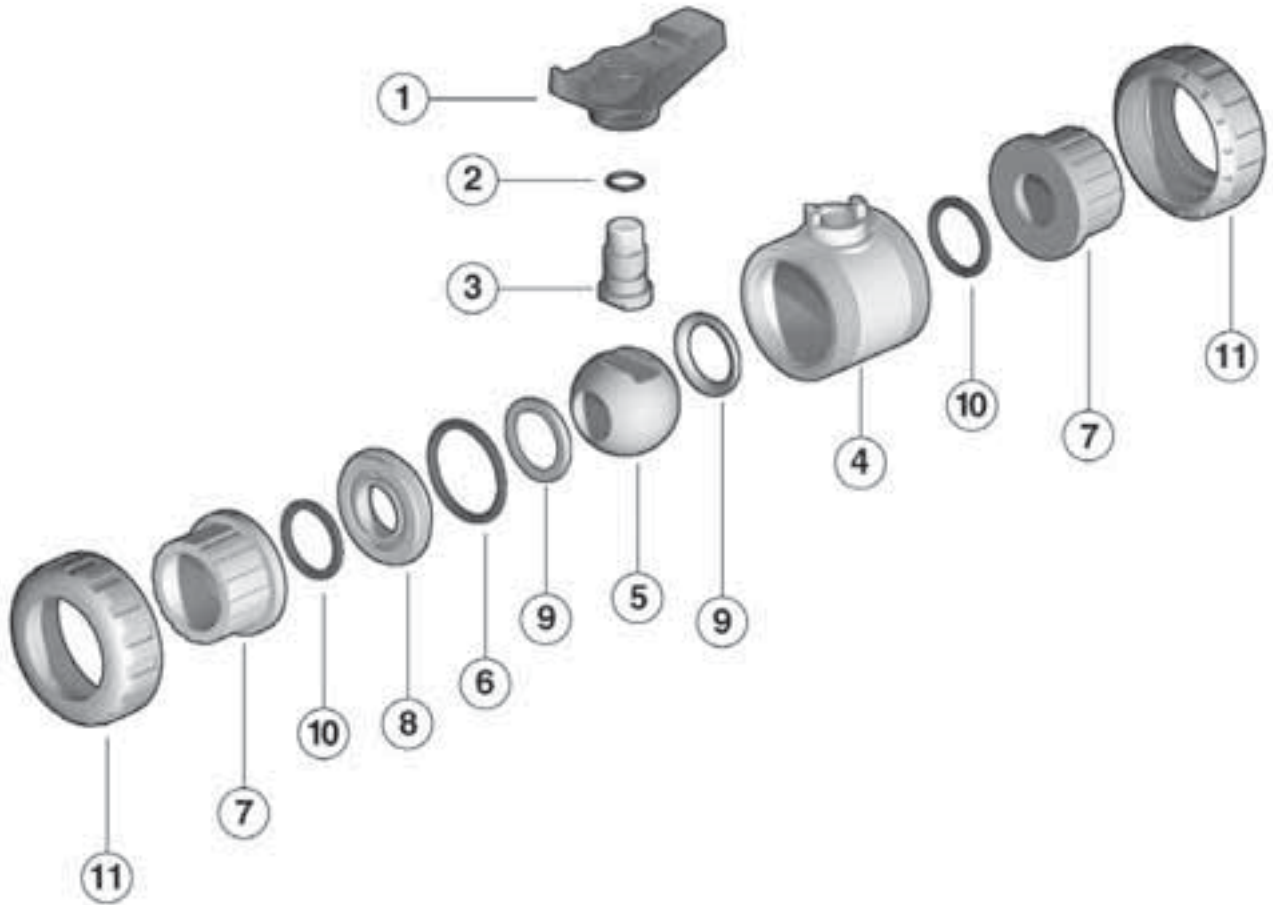

#	Component	Material	Qty
1	handle	High Impact PVC	1
2	stem o-ring	EPDM	1
3	stem	PVC	1
4	body	PVC	1
5	ball	PVC	1
6	body o-ring	EPDM	1
7*	end connector	PVC	2
8	support for ball seat	PVC	1
9	ball seat	PTFE – HDPE blend	2
10	socket o-ring	EPDM	2
11*	union nut	PVC	2

\* Spare parts available

## VE SERIES BALL VALVES

### Installation Procedures

1. Remove the union nuts (part #11 on previous page) and slide them onto the pipe.
2. Please refer to the appropriate connection style sub-section:
  - a. For socket style, solvent cement the end connectors (7) onto the pipe ends. For correct joining procedure, please refer to the section entitled, *“Joining Methods – Solvent Cementing”* in the IPEX Industrial Technical Manual Series, *“Volume I: Vinyl Process Piping Systems”*. **Be sure to allow sufficient cure time before continuing with the valve installation.**
  - b. For threaded style, thread the end connectors (7) onto the pipe ends. For correct joining procedure, please refer to the section entitled, *“Joining Methods – Threading”* in the IPEX Industrial Technical Manual Series, *“Volume I: Vinyl Process Piping Systems”*.
3. Open and close the valve to ensure that the ball seat support (8) is at the desired adjustment. If adjustment is required, ensure that the valve is in the closed position then remove the handle (1) from the valve stem. Line up the moldings on the handle with the slots in the ball seat support. Tighten or loosen to the desired position then replace the handle on the valve stem.
4. Ensure that the valve is in the closed position, and that the socket o-rings (10) are properly fitted in their grooves. Carefully place the valve in the system between the two end connections.
5. Tighten the union nut on the side opposite to that which is marked “ADJUST”. Hand tightening is typically sufficient to maintain a seal for the maximum working pressure. Over-tightening may damage the threads on the valve body and/or the union nut and may even cause the union nut to crack.
6. Tighten the union nut on the side marked “ADJUST”. Tightening the union nuts in this order results in the best possible valve performance due to optimum positioning and sealing of the ball and seat support system.
7. Open and close the valve to again ensure that the cycling performance is adequate. If adjustment is required, place the valve in the closed position, loosen the union nuts, remove the valve from system and then continue from Step 3.



## VE SERIES BALL VALVES

### Valve Maintenance

#### Disassembly

1. If removing the valve from an operating system, isolate the valve from the rest of the system. **Be sure to depressurize and drain the isolated branch and valve before continuing.**
2. Loosen both union nuts (11) and drop the valve out of the line. If retaining the socket o-rings (10), take care that they are not lost when removing the valve from the line.
3. To disassemble, place the valve in the closed position then remove the handle (1) from the valve stem.
4. Line up the moldings on the handle with the slots in the ball seat support (found on the side marked "ADJUST"). Loosen and remove the ball seat support (8) by turning in a counterclockwise direction.
5. Carefully press the ball (5) out of the valve body, taking care not to score or damage the outer surface.
6. To remove the stem (3), press it into the valve body (4) from above.
7. The stem o-ring (2), body o-ring (6), and ball seats (9) can now be removed and/or replaced.

#### Assembly

**Note:** Before assembling the valve components, it is advisable to lubricate the o-rings with a water soluble lubricant. **Be sure to consult the "IPEX Chemical Resistance Guide" and/or other trusted resources to determine specific lubricant-rubber compatibilities.**

1. Firmly place the ball seat (9) in the groove on the opposite end inside the valve body (4).
2. Properly fit the stem o-ring (2) in the groove on the stem (3), then insert the stem from the inside of the valve body.
3. Ensure that the valve stem is in the closed position then insert the ball (5) into the valve body taking care not to score or damage the outer surface.
4. Check that the ball seat (9) and body o-ring (6) are properly fitted on the ball seat support (8), then slightly hand tighten into the valve body. Line up the moldings on the handle (1) with the slots in the ball seat support then tighten by turning in a clockwise direction.
5. Replace the handle on the valve stem then cycle the valve open and closed to determine whether or not the performance is adequate. If so desired, the handle can be removed and used to make further adjustments.
6. Properly fit the socket o-rings (10) in their respective grooves.
7. Place the end connectors (7) into the union nuts (11), then thread onto the valve body taking care that the socket o-rings remain properly fitted in their grooves.



## MP SERIES COMPACT BALL VALVES

IPEX MP Series Compact Ball Valves are ideally suited to all kinds of plumbing and industrial applications where a compact, inexpensive on/off valve is required. The simple one piece PVC body with integral end connections eliminates potential problems caused by improper adjustment of the ball seating. MP Series Compact Ball Valves are part of our complete Xirtec®140 systems of pipe, valves, and fittings, engineered and manufactured to our strict quality, performance, and dimensional standards.

### Valve Availability

Body Material:	PVC
Size Range:	1/2" through 2"
Pressure:	150psi
Seats:	Teflon® (PTFE)
Seals:	EPDM
End Connections:	Socket (IPS) Threaded (FNPT)



ASTM D1784  
ASTM D2464  
ASTM D2466  
ASTM D2467  
ASTM F1498



ANSI B1.20.1



NSF 14/61



## MP SERIES COMPACT BALL VALVES

### Sample Specification

#### 1.0 Ball Valves - MP

##### 1.1 Material

- The valve body and ball shall be made of PVC compound which shall meet or exceed the requirements of cell classification 12454 according to ASTM D1784.

##### 1.2 Seats

- The ball seats shall be made of Teflon® (PTFE).

##### 1.3 Seals

- The o-ring seals shall be made of EPDM.

1.4 All wetted parts of the valves shall comply with NSF Standard 14/61 for potable water.

#### 2.0 Connections

##### 2.1 Socket style

- The IPS socket PVC end connections shall conform to the dimensional standards ASTM D2466 and ASTM D2467.

##### 2.2 Threaded style

- The female NPT threaded PVC end connections shall conform to the dimensional standards ASTM D2464, ASTM F1498, and ANSI B1.20.1.

#### 3.0 Design Features

- The valve shall be composed of a one piece PVC body.
- The end connections shall be an integral part of the body.
- All sizes shall allow for bi-directional flow.

#### 3.1 Pressure Rating

- All sizes shall be rated at 150psi at 73°F (23°C) (non-shock).

#### 3.2 Markings

- All valves shall be marked to indicate size, material designation, and manufacturers name or trade mark.

#### 3.3 Color Coding

- All PVC Schedule 40 valves shall be color-coded white.
- All PVC Schedule 80 valves shall be color-coded dark gray.

4.0 All valves shall be Xirtec® 140 by IPEX or approved equal.

### Dimensions and Weights

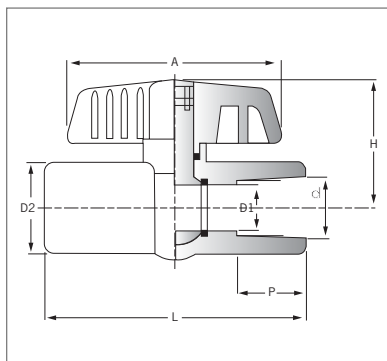

Size	Dimension (inches)								
	D1	d Socket	d Threaded	P	L	D2	H	A	W (lbs)
1/2	0.59	0.84	1/2 NPT	0.88	3.11	1.38	1.85	2.76	0.24
3/4	0.79	1.05	3/4 NPT	1.00	3.54	1.58	2.24	3.03	0.35
1	0.98	1.32	1 NPT	1.13	4.13	1.89	2.40	3.50	0.52
1-1/4	1.26	1.66	1-1/4 NPT	1.25	4.76	2.13	2.60	3.50	0.74
1-1/2	1.54	1.90	1-1/2 NPT	1.38	5.00	2.44	2.91	4.37	1.06
2	1.97	2.38	2 NPT	1.50	5.87	2.95	3.15	5.47	1.72

### Flow Coefficients

Size	C <sub>v</sub>
1/2	8.80
3/4	13.2
1	25.2
1-1/4	38.5
1-1/2	51.3
2	96.7

## MP SERIES COMPACT BALL VALVES

### Pressure – Temperature Ratings

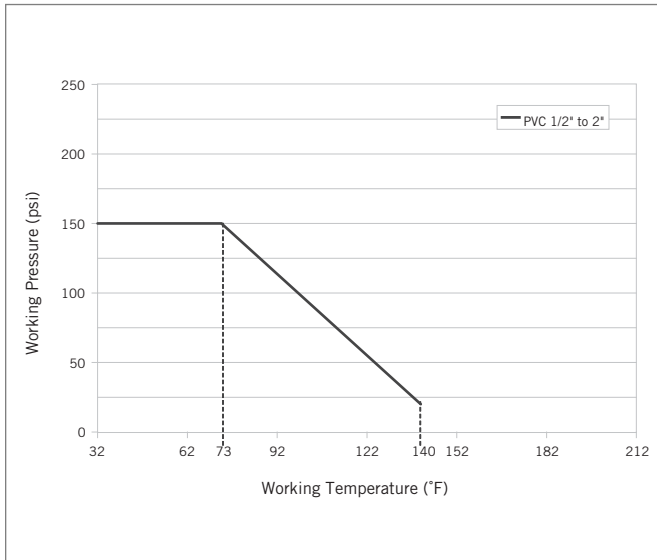

### Pressure Loss Chart

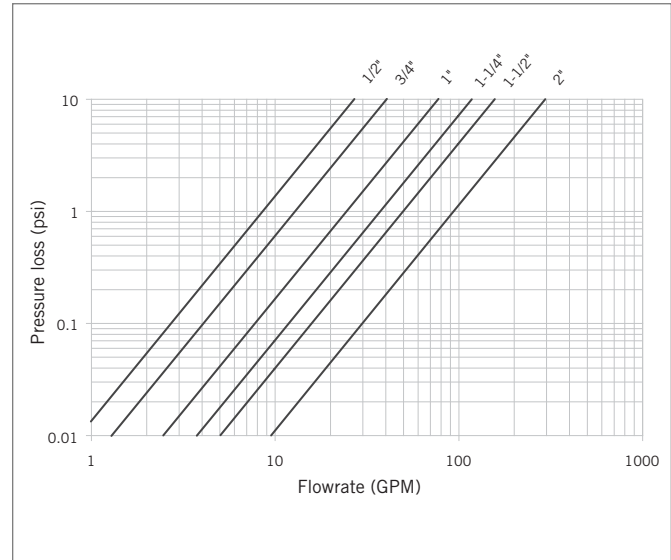

BALL VALVES

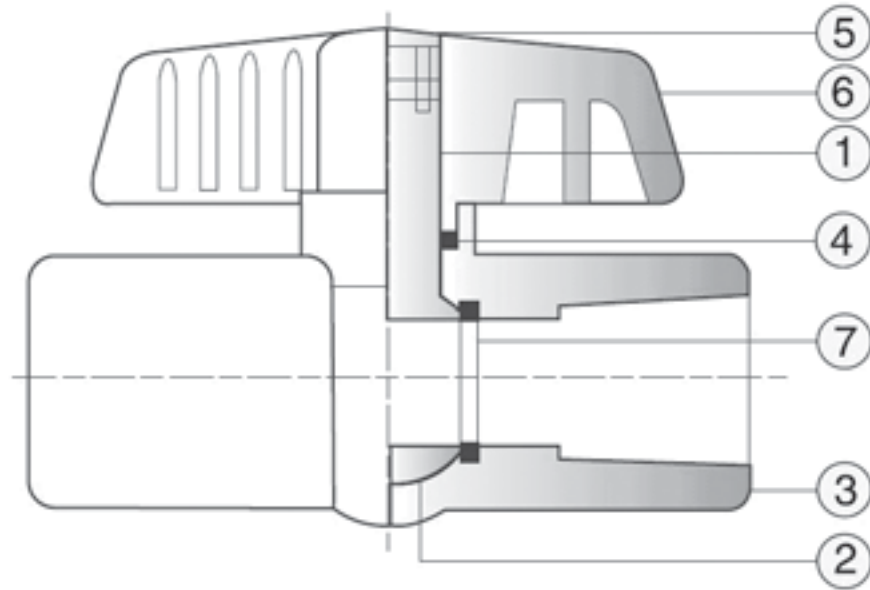

#	Component	Material	Qty
1	stem	PVC	1
2	ball	PVC	1
3	body	PVC (white) / PVC (gray)	1
4	stem o-ring	EPDM	1
5	cap	ABS	1
6	handle	ABS	1
7	seat	PTFE	2

## MP SERIES COMPACT BALL VALVES

### Installation Procedures

1. Please refer to the appropriate connection style sub-section:
  - a. For socket style, solvent cement each pipe end into the body of the valve. For correct joining procedure, please refer to the section entitled, "*Joining Methods – Solvent Cementing*" in the IPEX Industrial Technical Manual Series, "*Volume I: Vinyl Process Piping Systems*". **Be sure to allow sufficient cure time before pressurizing the system.**
  - b. For threaded style, thread each pipe end into the body of the valve. For correct joining procedure, please refer to the section entitled, "*Joining Methods – Threading*" in the IPEX Industrial Technical Manual Series, "*Volume I: Vinyl Process Piping Systems*".

### Removal From the System

1. If removing the valve from an operating system, isolate the valve from the rest of the system. **Be sure to depressurize and drain the isolated branch and valve before continuing.**
2. Please refer to the appropriate connection style sub-section:
  - a. For socket style, cut the pipe as close to the ends of the valve body as possible. The valve can now be replaced.
  - b. For threaded style, unthread the pipe ends from the valve body. The valve can now be reused and/or replaced.

**Note:** The MP Compact Ball Valve is a molded-in-place valve. It cannot be disassembled.

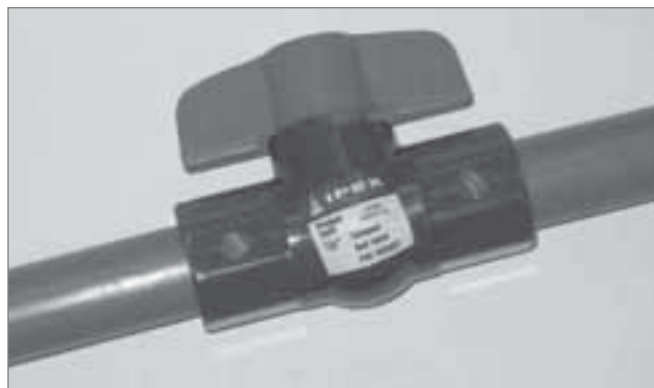

## TK SERIES 3-WAY BALL VALVES

IPEX TK Series 3-Way Ball Valves can be used for flow diverting, mixing, or on/off isolation. They will replace a Tee + 2 valve linkage assembly at reduced cost and space, along with shorter installation and maintenance time. The patented seat stop carrier allows for in-line micro-adjustment of the ball seating, and features o-ring cushioning to minimize wear and prevent seizing. Integral mounting flange and bracketing allows for direct actuation and simple support, while a locking handle can prevent improper positioning. TK Series 3-Way Ball Valves are part of our complete Xirtec®140 systems of pipe, valves, and fittings, engineered and manufactured to our strict quality, performance, and dimensional standards.

### Valve Availability

Body Material:	PVC
Size Range:	1/2" through 2"
Pressure:	232psi
Seats:	Teflon® (PTFE)
Seals:	EPDM or Viton® (FPM)
End Connections:	Socket (IPS) Threaded (FNPT)



ASTM D1784  
ASTM D2464  
ASTM D2466  
ASTM D2467  
ASTM F1498



ANSI B1.20.1



## TK SERIES 3-WAY BALL VALVES

### Sample Specification

#### 1.0 Ball Valves - TK

##### 1.1 Material

- The valve body, stem, ball, end connectors, and unions shall be made of PVC compound which shall meet or exceed the requirements of cell classification 12454 according to ASTM D1784.

##### 1.2 Seats

- The ball seats shall be made of Teflon® (PTFE).

##### 1.3 Seals

- The o-ring seals shall be made of EPDM.
- or The o-ring seals shall be made of Viton® (FPM).

- 1.4 All wetted parts of the valves shall comply with standards that are equivalent to NSF Standard 61 for potable water.

#### 2.0 Connections

##### 2.1 Socket style

- The IPS socket PVC end connectors shall conform to the dimensional standards ASTM D2466 and ASTM D2467.

##### 2.2 Threaded style

- The female NPT threaded PVC end connectors shall conform to the dimensional standards ASTM D2464, ASTM F1498, and ANSI B1.20.1.

#### 3.0 Design Features

- All valves shall be true union at all three ports.
- All sizes shall be full port.
- Valve design shall permit positive shutoff of any of the three ports.
- Balls shall be of T-port or L-port design (specifier must select one).
- The valve shall have blocking seat supports at all three ports.

- The threaded carrier (ball seat support) shall be adjustable with the valve installed.
- The valve body, union nuts, and carrier shall have deep square style threads for increased strength.
- The ball shall be machined smooth to minimize wear on valve seats.
- All valve seats shall have o-ring backing cushions to compensate for wear and prevent seizure of the ball.
- The thickness of the valve body shall be the same at all three ports.
- The stem design shall feature a shear point above the o-ring to maintain system integrity in the unlikely event of a stem breakage.
- The handle shall feature a locking mechanism to prevent unintentional movement.
- The handle shall incorporate a feature to allow the valve position to be secured with a padlock.
- The handle shall incorporate a removable tool for adjustment of the threaded carrier.
- The top of the stem shall incorporate molded features to indicate port location and ball position.
- All valves shall have integrally molded mounting flanges for support and actuation.

#### 3.1 Pressure Rating

- All valves shall be rated at 232psi at 73°F (23°C).

#### 3.2 Markings

- All valves shall be marked to indicate size, material designation, and manufacturer's name or trade mark.

#### 3.3 Color Coding

- All PVC valves shall be color-coded dark gray.

- 4.0 All valves shall be Xirtec® 140 by IPEX or approved equal.

## TK SERIES 3-WAY BALL VALVES

### Dimensions

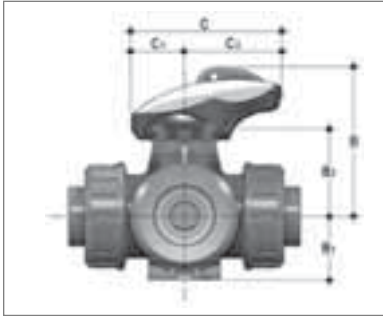

Size	Dimension (inches)					
	C	C1	C2	B	B1	B2
1/2	3.29	1.16	2.13	3.44	1.30	1.97
3/4	3.86	1.40	2.46	3.88	1.54	2.22
1	4.13	1.46	2.68	4.17	1.77	2.42
1-1/4	5.49	2.01	3.48	5.31	2.01	3.01
1-1/2	5.49	2.01	3.48	5.47	2.24	3.17
2	6.06	2.01	4.06	6.26	2.72	3.84

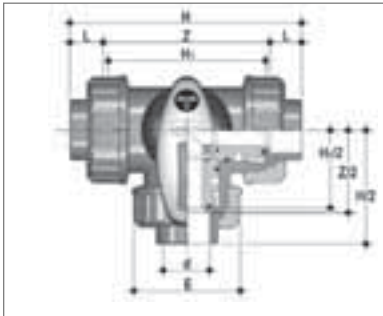

Size	IPS Socket Connections - Dimension (inches)					
	d	L	Z	H	H1	E
1/2	0.84	0.91	3.43	5.20	3.15	2.17
3/4	1.05	1.00	4.26	6.27	3.94	2.60
1	1.32	1.13	4.59	6.85	4.33	2.95
1-1/4	1.66	1.26	5.55	8.07	5.16	3.43
1-1/2	1.90	1.38	6.20	8.96	5.83	3.94
2	2.38	1.50	7.50	10.51	7.05	4.80

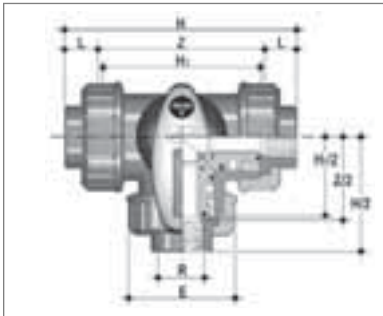

Size	Female NPT Threaded Connections - Dimension (inches)					
	R	L	Z	H	H1	E
1/2	1/2-NPT	0.71	3.56	4.96	3.15	2.17
3/4	3/4-NPT	0.71	4.35	5.76	3.94	2.60
1	1-NPT	0.89	4.78	6.56	4.33	2.95
1-1/4	1-1/4-NPT	0.99	5.73	7.71	5.16	3.43
1-1/2	1-1/2-NPT	0.97	6.38	8.32	5.83	3.94
2	2-NPT	1.17	7.66	9.99	7.05	4.80

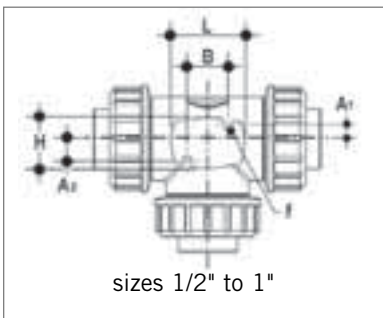

Size	Mounting Flanges - Dimension (inches)					
	A <sub>1</sub>	A <sub>2</sub>	B	L	H	f
1/2	0.28	0.38	0.81	1.46	1.00	0.18
3/4	0.31	0.47	0.87	1.65	1.18	0.18
1	0.35	0.49	1.18	1.97	1.32	0.24
1-1/4	0.41	0.53	1.42	2.60	1.57	0.24
1-1/2	0.45	0.57	1.46	2.80	1.69	0.28
2	0.59	0.79	1.77	3.35	1.69	0.28

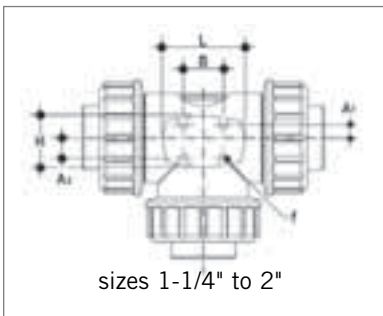

## TK SERIES 3-WAY BALL VALVES

### Dimensions (cont'd)

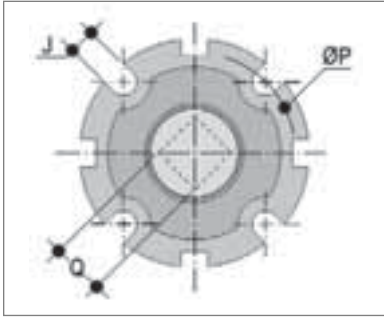

Size	Dimension (inches)		
	ISO	J	P
1/2	F04	0.20	1.65
3/4	F05	0.28	1.97
1	F05	0.28	1.97
1-1/4	F07	0.35	2.76
1-1/2	F07	0.35	2.76
2	F07	0.35	2.76

### Weights

Size	Approximate Weight (lbs)	
	IPS Socket	FNPT Threaded
1/2	0.77	0.77
3/4	1.32	1.32
1	1.87	1.87
1-1/4	2.98	2.98
1-1/2	3.86	3.86
2	6.50	6.50

### Flow Coefficients

Size	C <sub>v</sub>				
	Position				
	A	B	C	D	E
1/2	3.85	2.45	4.55	13.7	5.11
3/4	9.50	6.65	10.2	26.6	10.5
1	14.4	9.80	17.2	53.2	18.6
1-1/4	27.3	18.9	32.2	73.5	33.3
1-1/2	33.3	23.1	42.0	119	43.4
2	63.0	43.4	84.0	224	85.4

### Pressure - Temperature Ratings

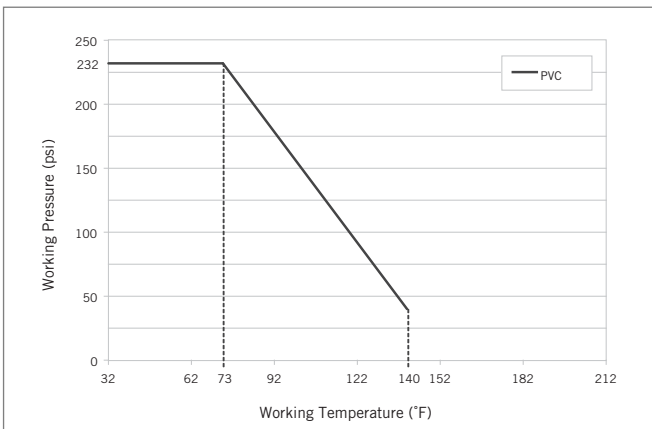

## TK SERIES 3-WAY BALL VALVES

### Operating Positions

Position	T-Port	L-Port
0°	mixing	diverting
90°	diverting	closed
180°	straight flow	closed
270°	diverting	diverting

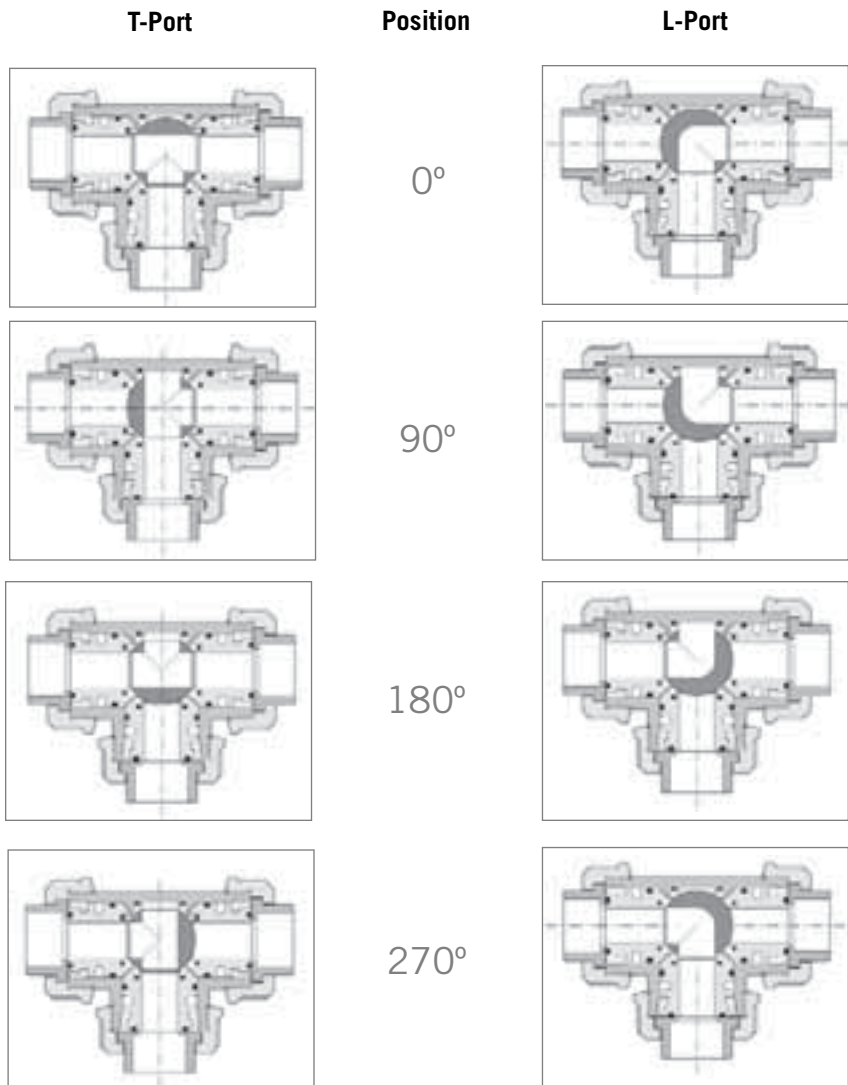

**BALL VALVES**

## TK SERIES 3-WAY BALL VALVES

### Pressure Loss Charts

Position A:

- T-Port
- Center Inlet
- Diverting Flow

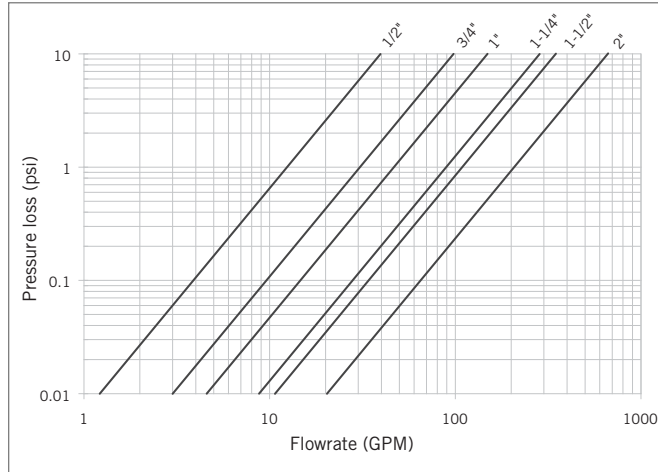
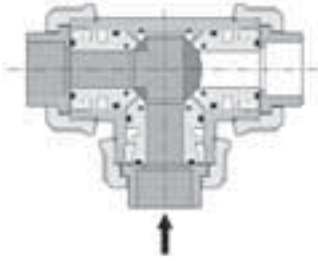

Position B:

- T-Port
- Center Inlet
- Separating Flow

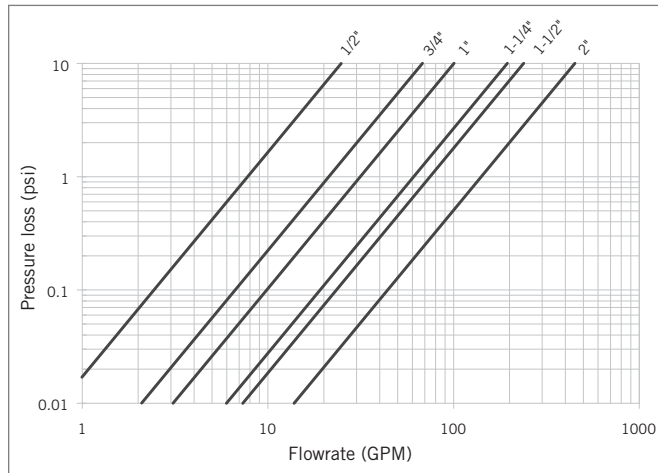
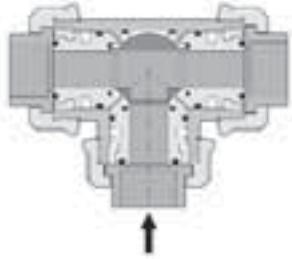

Position C:

- T-Port
- Side Inlet
- Diverting Flow

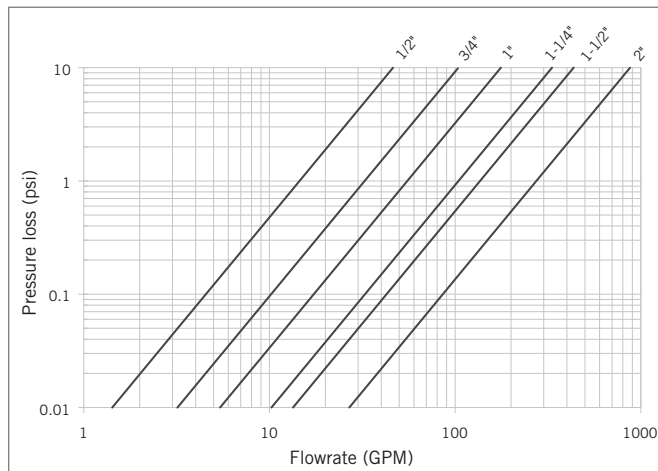
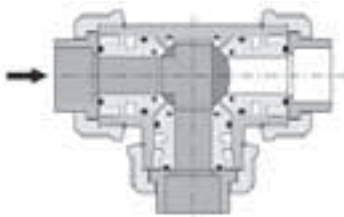

## TK SERIES 3-WAY BALL VALVES

### Pressure Loss Charts (cont'd)

Position D:

- T-Port
- Side Inlet
- Straight Flow

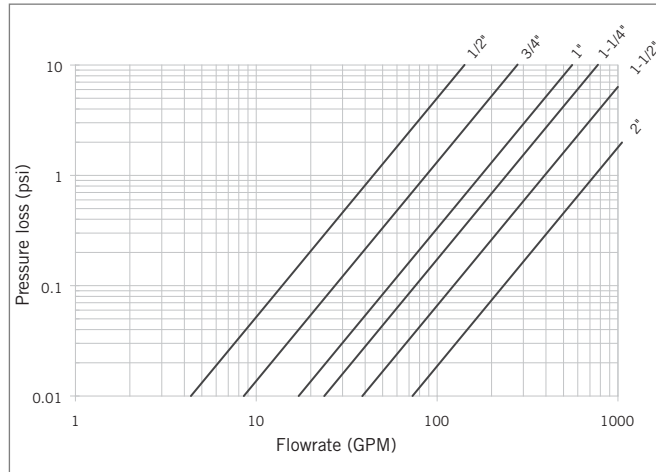
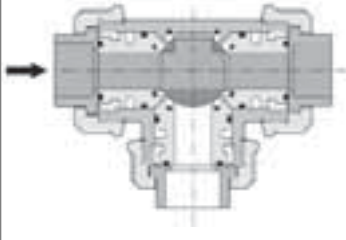

Position E:

- L-Port
- Any Inlet
- Diverting Flow

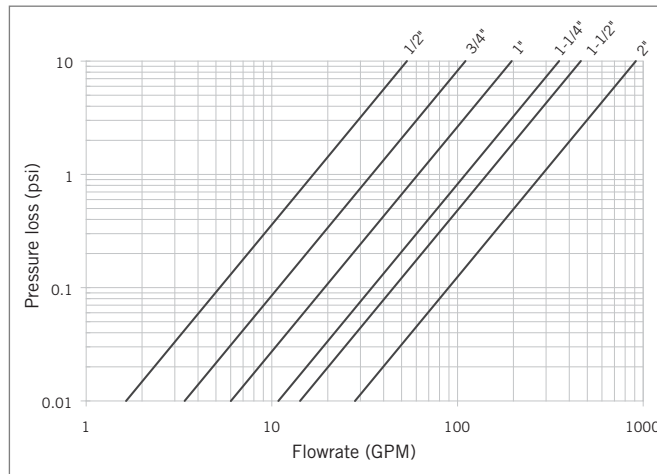
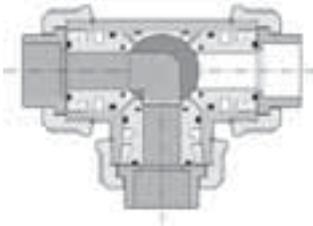

### TK SERIES 3-WAY BALL VALVES

#### Components

BALL VALVES

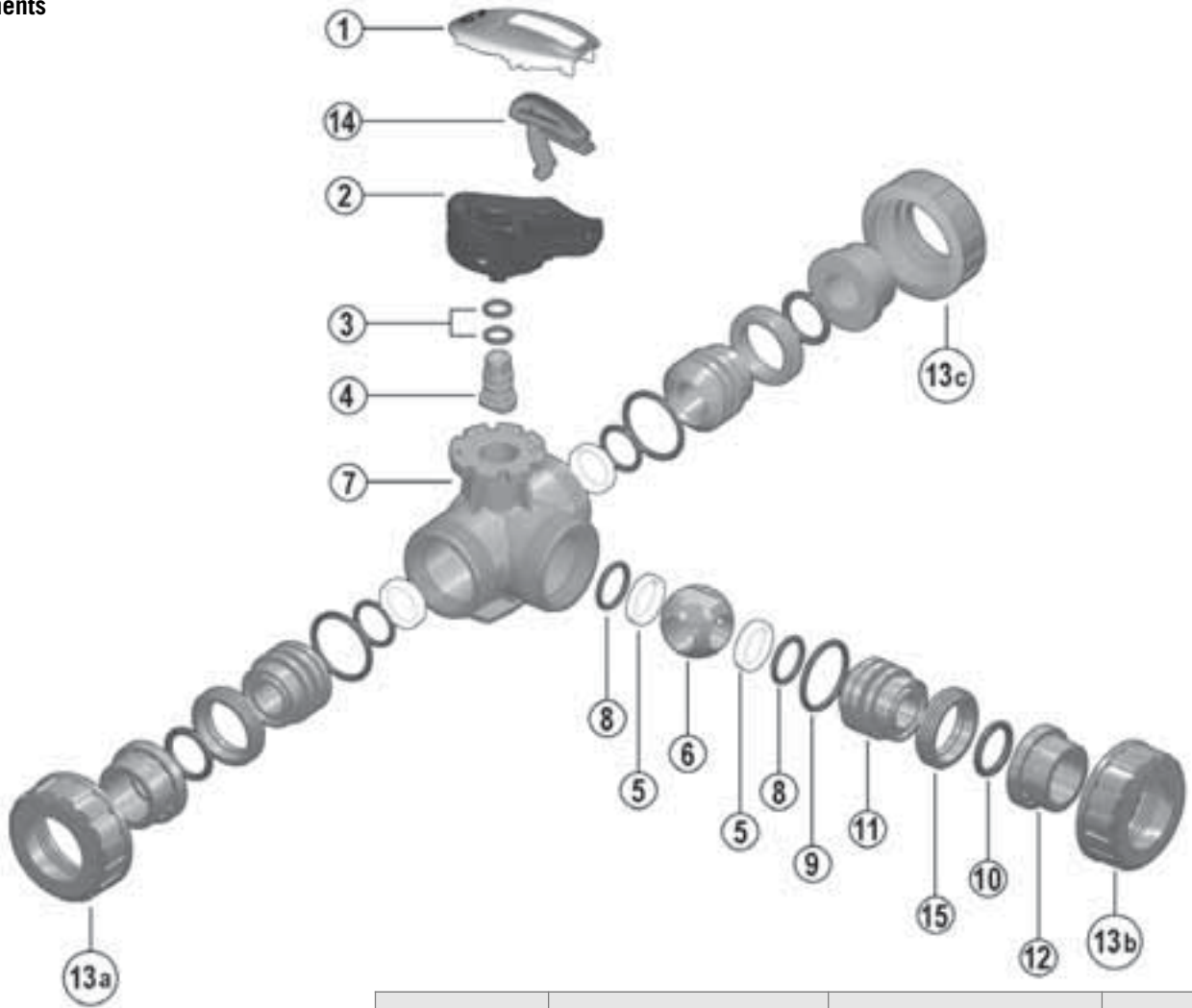

#	Component	Material	Qty
1*	insert tool	PVC	1
2	handle	PVC	1
3*	stem o-ring	EPDM or Viton®	2
4	stem	PVC	1
5	ball seat	PTFE	4
6	ball	PVC	1
7	body	PVC	1
8*	backing o-ring	EPDM or Viton®	4
9*	body o-ring	EPDM or Viton®	3
10*	socket o-ring	EPDM or Viton®	3
11	support for ball seat	PVC	3
12*	end connector	PVC	3
13*	union nut	PVC	3
14	blocking button	POM	1
15	stop ring	PVC	3

\* Spare parts available.

## TK SERIES 3-WAY BALL VALVES

### Installation Procedures

1. For socket and threaded style connections, remove the union nuts (part #13 on previous page) and slide them onto the pipe. For flanged connections, remove the union nut / flange assemblies from the valve.
2. Please refer to the appropriate connection style sub-section:
  - a. For socket style, solvent cement the end connectors (12) onto the pipe ends. For correct joining procedure, please refer to the section entitled, *“Joining Methods – Solvent Cementing”* in the IPEX Industrial Technical Manual Series, *“Volume I: Vinyl Process Piping Systems”*. **Be sure to allow sufficient cure time before continuing with the valve installation.**
  - b. For threaded style, thread the end connectors (12) onto the pipe ends. For correct joining procedure, please refer to the section entitled, *“Joining Methods – Threading”* in the IPEX Industrial Technical Manual Series, *“Volume I: Vinyl Process Piping Systems”*.
3. Open and close the valve to ensure that the seat supports (11) are at the desired adjustment. If adjustment is required, remove the insert tool (1) from the handle (2). Line up the moldings on the tool with the slots in the seat supports. Tighten or loosen to the desired position then replace the tool on the handle. For correct alignment of the ball and seat support system, adjustment should begin with the center port.
4. Ensure that the socket o-rings (10) are properly fitted in their grooves then carefully place the valve in the system between the end connections. If anchoring is required, fix the valve to the supporting structure via the integral mounting flange on the bottom of the valve body (7).
5. Tighten the three union nuts. Hand tightening is typically sufficient to maintain a seal for the maximum working pressure. Over-tightening may damage the threads on the valve body and/or the union nut, and may even cause the union nut to crack.
6. Open and close the valve to ensure that the cycling performance is adequate. If adjustment is required, loosen the union nuts, remove the valve from the system, and then continue from Step 3.

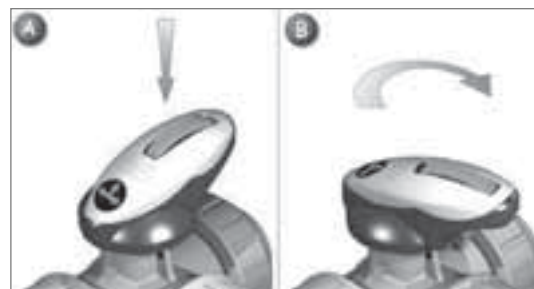

## TK SERIES 3-WAY BALL VALVES

### Valve Maintenance

#### Disassembly

1. If removing the valve from an operating system, isolate the valve from the rest of the system. **Be sure to depressurize and drain the isolated branch and valve before continuing.**
2. Loosen the three union nuts (13) and drop the valve out of the line. If retaining the socket o-rings (10), take care that they are not lost when removing the valve from the line.
3. To disassemble, rotate the handle (2) to the following position:
  - a. For T-Port valves, the three arrows must line up with the three valve ports (The valve must be open at all three ports).
  - b. For L-Port valves, the two arrows must line up with ports "a" and "b" (see component diagram).
4. Remove the insert tool (1) from the handle then line up the moldings on the tool with the slots in the seat supports (11). Loosen and remove all three seat supports from the valve body (7).
5. Remove the ball (6) from the valve body while taking care not to score or damage the outer surface.
6. Remove the handle from the stem (4) by pulling upwards. To remove the stem, push it into the valve body from above.
7. Remove the seats (5), backing o-rings (8), and body o-rings (9) from the seat supports.
8. Remove the seat and backing o-ring from the inside of the valve body.
9. Remove the stem o-rings (3).
10. The valve components can now be checked for problems and/or replaced.



#### Assembly

**Note:** Before assembling the valve components, it is advisable to lubricate the o-rings with a water soluble lubricant. **Be sure to consult the "IPEX Chemical Resistance Guide" and/or other trusted resources to determine specific lubricant-rubber compatibilities.**

1. Properly fit the stem o-rings (3) in the grooves on the stem (4), then insert the stem from the inside of the valve body (7).
2. Line up the markings on the stem with the ports in the valve body.
3. Replace the backing o-ring (8) and seat (5) at the back of the valve body.
4. Insert the ball (6) into the valve body while ensuring that the ports line up with the markings on the stem.
5. Ensure that all body o-rings (9), backing o-rings, and seats are properly fitted on the three seat supports (11). Starting with the center port, tighten each support into the valve body using the insert tool (1).
6. Replace the handle (2) on the stem while ensuring that the position markings on the handle line up with those on the stem. Replace the insert tool on the handle.
7. Properly fit the socket o-rings (10) in their respective grooves.
8. Place the end connectors (12) into the union nuts (13), then thread onto the valve body taking care that the socket o-rings remain properly fitted in their grooves.

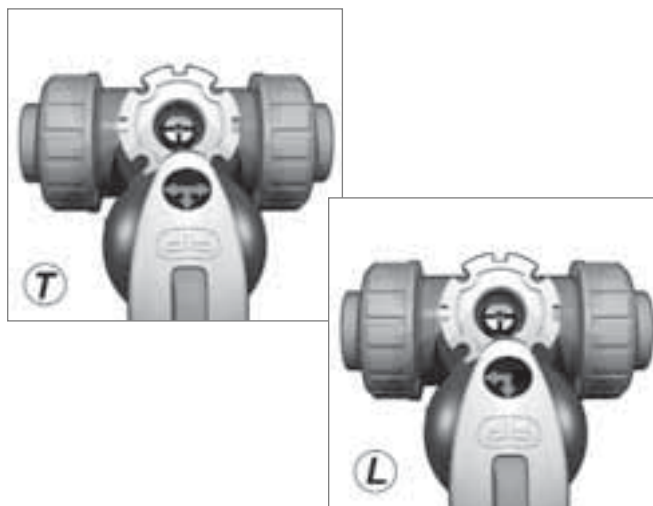

## TKD SERIES 3-WAY BALL VALVES

IPEX TKD Series 3-Way Ball Valves can be used for flow diverting, mixing, or on/off isolation. They will replace a Tee + 2 valve linkage assembly at reduced cost and space, along with shorter installation and maintenance time. The patented seat stop carrier allows for in-line microadjustment of the ball seating, and features o-ring cushioning to minimize wear and prevent seizing. The TKD also includes our patented DUAL BLOCK® locking union nut system, which ensures the nuts are held in position even under severe service conditions such as high vibration or thermal expansion. Integral mounting flange and bracketing allows for direct actuation and simple support, while a locking handle can prevent improper positioning. TKD Series 3-Way Ball Valves are part of our complete Xirtec®140 systems of pipe, valves and fittings, engineered and manufactured to our strict quality, performance, and dimensional standards.

### Valve Availability

Body Material:	PVC
Size Range:	1/2" through 2"
Pressure:	232psi
Seats:	Teflon® (PTFE)
Seals:	EPDM or Viton® (FKM)
End Connections:	Socket (IPS) Threaded (FNPT)



ASTM D1784  
ASTM D2464  
ASTM D2466  
ASTM D2467  
ASTM F1498



ANSI B1.20.1



## TKD SERIES 3-WAY BALL VALVES

**Sample Specification****1.0 Ball Valves - TKD****1.1 Material**

- The valve body, stem, ball, end connectors, and unions shall be made of PVC compound which shall meet or exceed the requirements of cell classification 12454 according to ASTM D1784.

**1.2 Seats**

- The ball seats shall be made of Teflon® (PTFE).

**1.3 Seals**

- The o-ring seals shall be made of EPDM.
- or The o-ring seals shall be made of Viton® (FKM).

- 1.4** All wetted parts of the valves shall comply with standards that are equivalent to NSF Standard 61 for potable water.

**2.0 Connections****2.1 Socket style**

- The IPS socket PVC end connectors shall conform to the dimensional standards ASTM D2466 and ASTM D2467.

**2.2 Threaded style**

- The female NPT threaded PVC end connectors shall conform to the dimensional standards ASTM D2464, ASTM F1498, and ANSI B1.20.1.

**3.0 Design Features**

- All valves shall be true union at all three ports.
- All sizes shall be full port.
- Valve design shall permit positive shutoff of any of the three ports.
- Balls shall be of T-port or L-port design (specifier must select one).
- The valve shall have blocking seat supports at all three ports.

- The threaded carrier (ball seat support) shall be adjustable with the valve installed.
- The valve body, union nuts, and carrier shall have deep square style threads for increased strength.
- The ball shall be machined smooth to minimize wear on valve seats.
- All valve seats shall have o-ring backing cushions to compensate for wear and prevent seizure of the ball.
- The thickness of the valve body shall be the same at all three ports.
- The stem design shall feature a shear point above the o-ring to maintain system integrity in the unlikely event of a stem breakage.
- The valve shall include the DUAL BLOCK® union nut locking mechanism
- The handle shall incorporate an optional feature to allow the valve position to be secured with a padlock.
- The handle shall incorporate a removable tool for adjustment of the threaded carrier.
- The top of the stem shall incorporate molded features to indicate port location and ball position.
- All valves shall have integrally molded mounting flanges for support and actuation

**3.1 Pressure Rating**

- All valves shall be rated at 232psi at 73°F (23°C).

**3.2 Markings**

- All valves shall be marked to indicate size, material designation, and manufacturers name or trade mark.

**3.3 Color Coding**

- All PVC valves shall be color-coded dark gray.

- 4.0** All valves shall be Xirtec® 140 by IPEX or approved equal.

## TKD SERIES 3-WAY BALL VALVES

### Dimensions

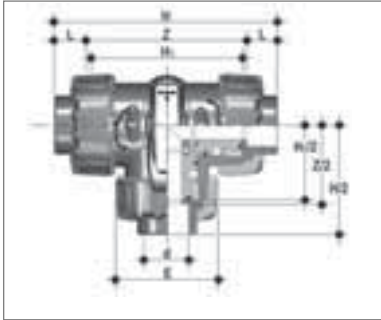

IPS Socket Connections - Dimension (inches)						
Size (d)	DN	E	H	H1	L	Z
1/2	0.59	2.13	5.20	3.15	0.91	3.43
3/4	0.79	2.56	6.27	3.94	1.00	4.26
1	0.98	2.87	6.85	4.33	1.13	4.59
1-1/4	1.26	3.39	8.07	5.16	1.26	5.55
1-1/2	1.57	3.86	8.96	5.83	1.38	6.20
2	1.97	4.80	10.51	7.05	1.50	7.50

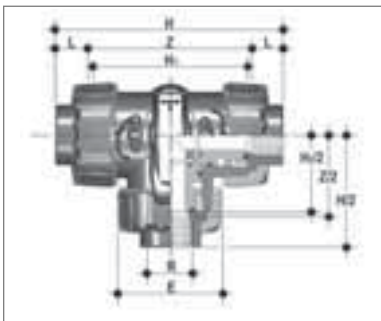

Female NPT Socket Connections - Dimension (inches)						
Size (R)	DN	E	H	H1	L	Z
1/2	0.59	2.13	4.96	3.15	0.71	3.56
3/4	0.79	2.56	5.76	3.94	0.71	4.35
1	0.98	2.87	6.56	4.33	0.89	4.78
1-1/4	1.26	3.39	7.71	5.16	0.99	5.73
1-1/2	1.57	3.86	8.32	5.83	0.97	6.38
2	1.97	4.80	9.99	7.05	1.17	7.66

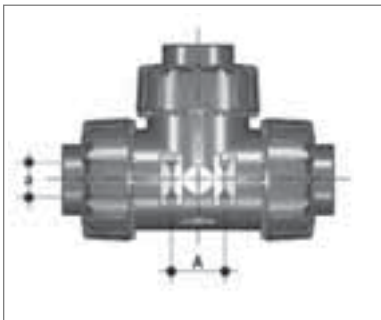

Mounting Flanges - Dimension (inches)			
Size	DN	a	A
1/2	0.59	0.79	1.22
3/4	0.79	0.79	1.22
1	0.98	0.79	1.22
1-1/4	1.26	1.18	1.97
1-1/2	1.57	1.18	1.97
2	1.97	1.18	1.97

## TKD SERIES 3-WAY BALL VALVES

### Weights

Size (inches)	Approximate Weight (lbs)	
	IPS Socket	FNPT Threaded
1/2	0.68	0.68
3/4	1.21	1.21
1	1.74	1.74
1-1/4	2.81	2.81
1-1/2	3.66	3.66
2	6.17	6.17

### Flow Coefficients

Size	C <sub>v</sub>				
	Position				
	A	B	C	D	E
1/2	3.85	2.45	4.55	13.7	5.11
3/4	9.50	6.65	10.2	26.6	10.5
1	14.4	9.80	17.2	53.2	18.6
1-1/4	27.3	18.9	32.2	73.5	33.3
1-1/2	33.3	23.1	42.0	119	43.4
2	63.0	43.4	84.0	224	85.4

BALL VALVES

### Pressure - Temperature Ratings

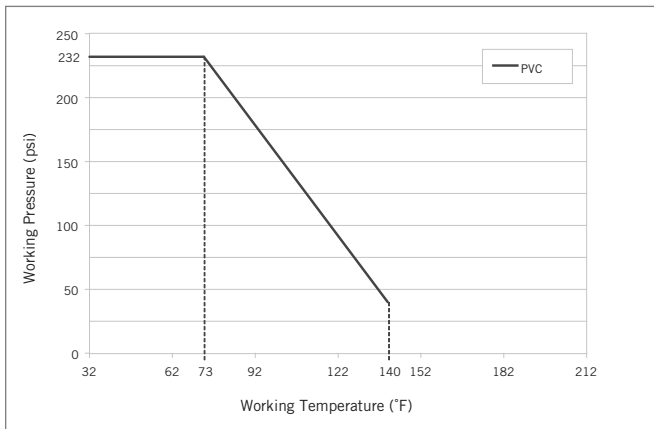

## TKD SERIES 3-WAY BALL VALVES

### Operating Positions

Position	T-Port	L-Port
0°	mixing	diverting
90°	diverting	closed
180°	straight flow	closed
270°	diverting	diverting

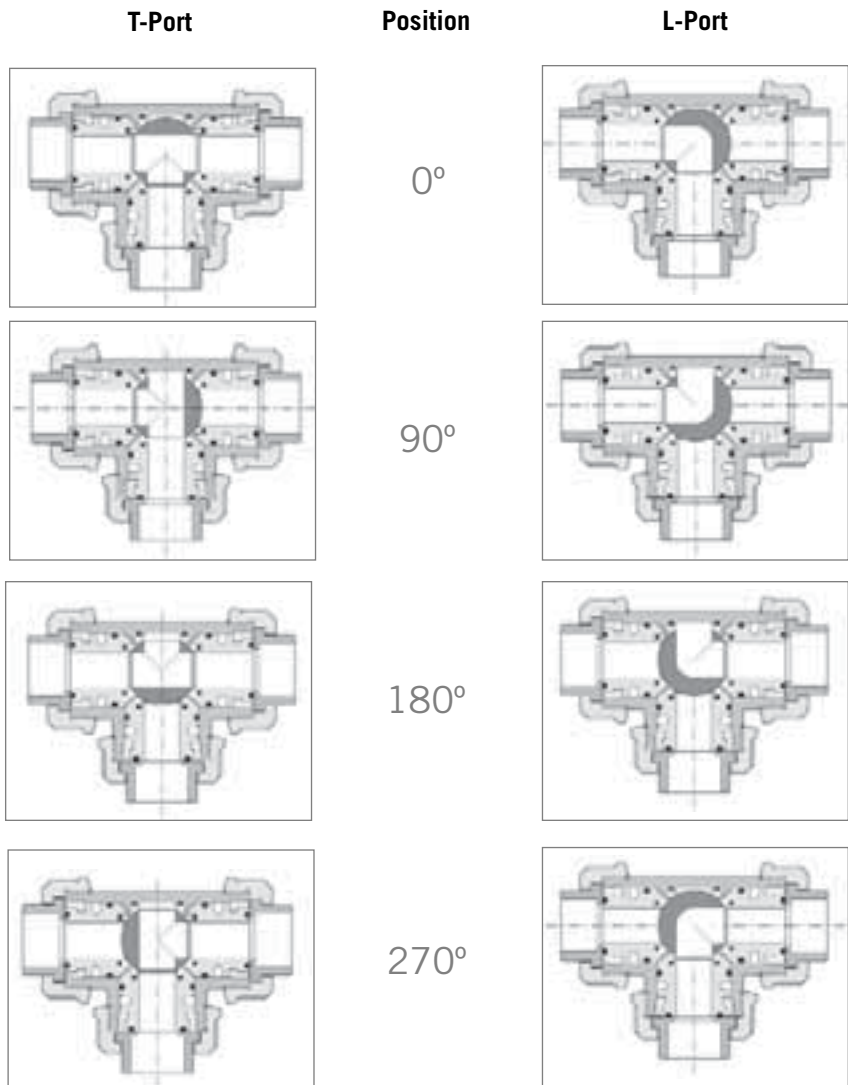

**BALL VALVES**

### TKD SERIES 3-WAY BALL VALVES

#### Pressure Loss Charts

BALL VALVES

Position A:

- T-Port
- Center Inlet
- Diverting Flow

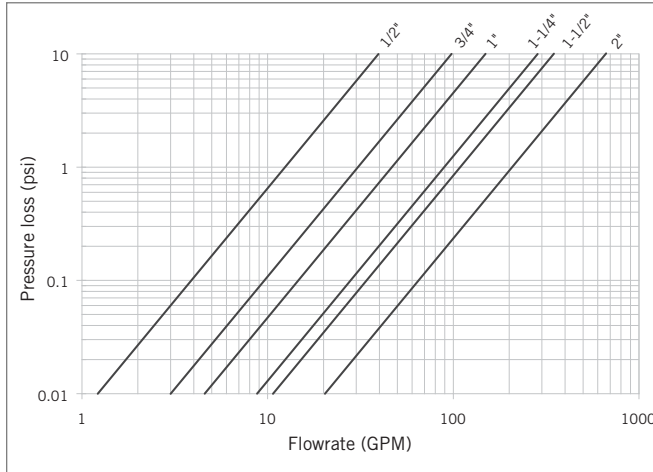
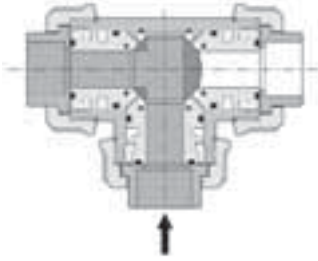

Position B:

- T-Port
- Center Inlet
- Separating Flow

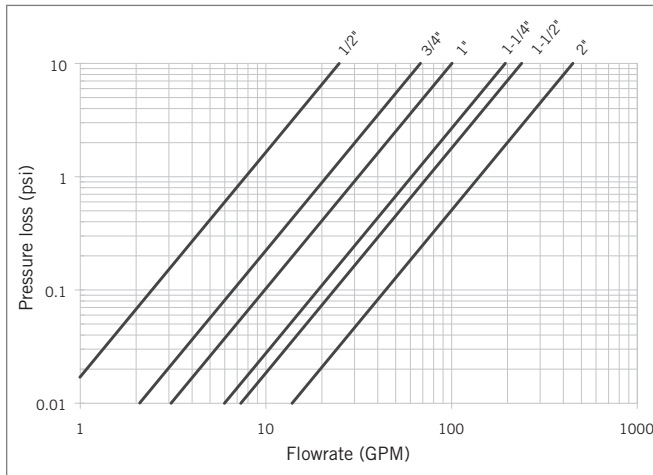
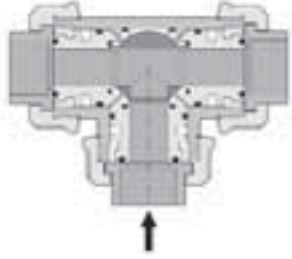

Position C:

- T-Port
- Side Inlet
- Diverting Flow

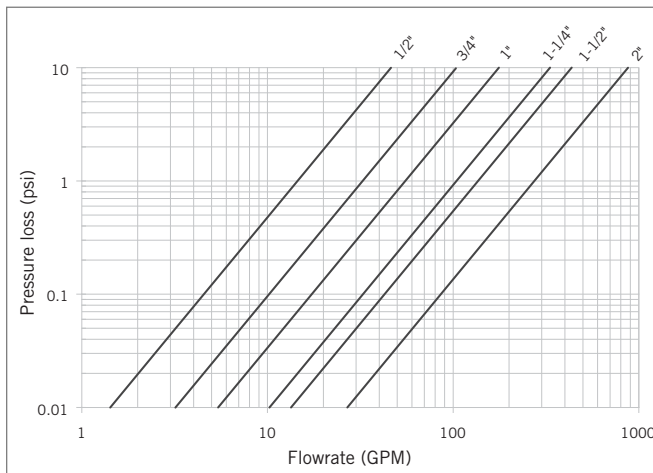
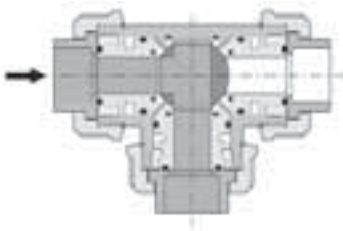

## TKD SERIES 3-WAY BALL VALVES

### Pressure Loss Charts (cont'd)

Position D:

- T-Port
- Side Inlet
- Straight Flow

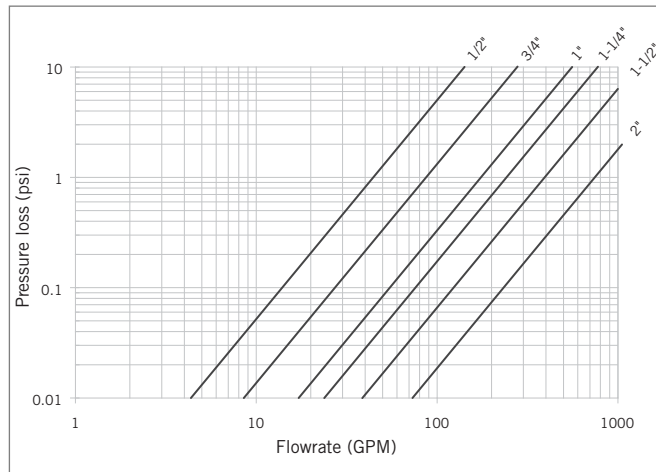
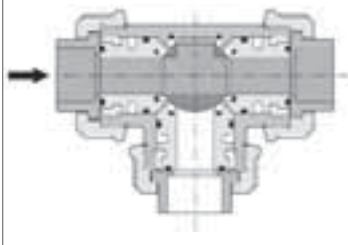

Position E:

- L-Port
- Any Inlet
- Diverting Flow

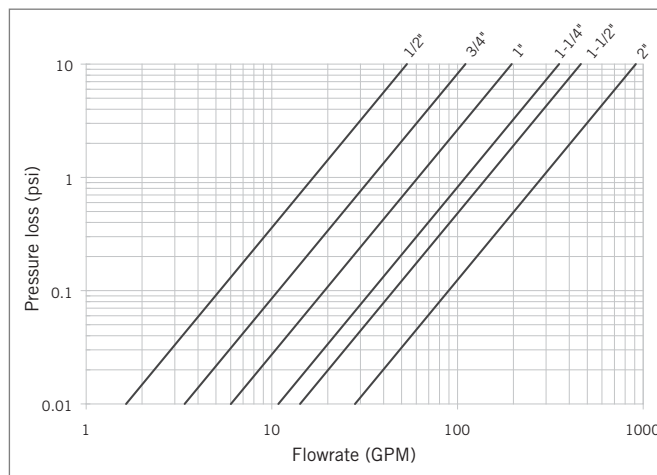
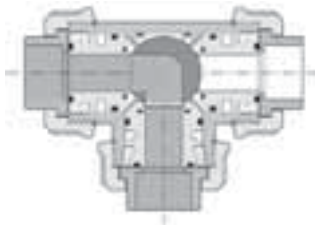

## TKD SERIES 3-WAY BALL VALVES

### Components

BALL VALVES

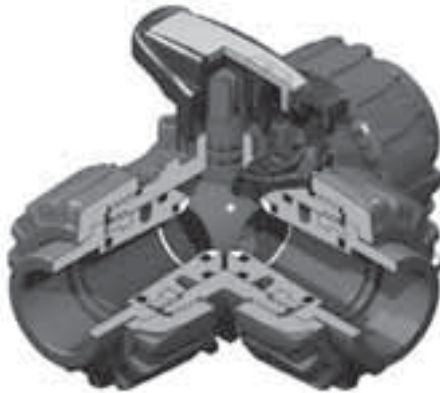
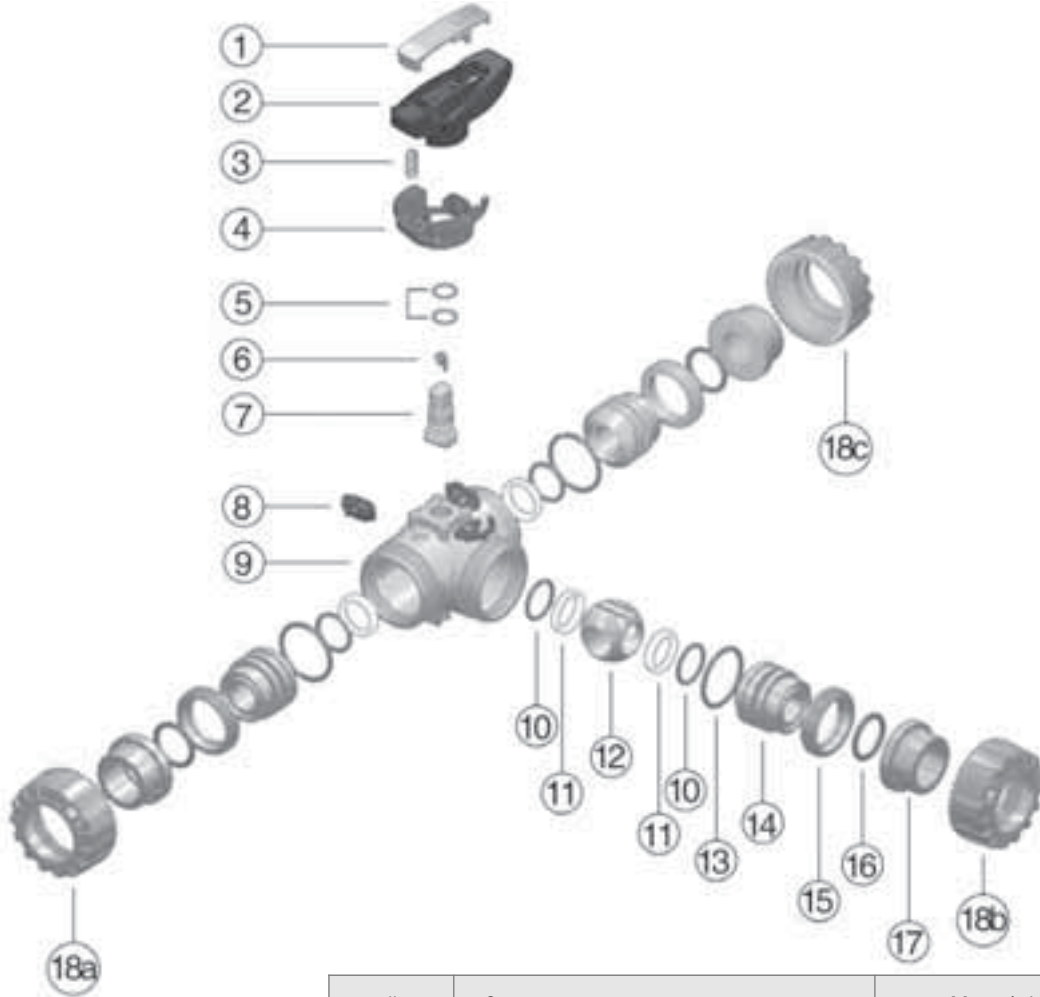

#	Component	Material	Qty
1	insert	U-PVC	1
2	handle	U-PVC	1
3	spring (SHKD)	Stainless Steel	1
4**	safety handle block (SHKD)	PP-GR	1
5*	stem o-rings	EPDM-FKM	2
6	position indicator	POM	1
7	stem	U-PVC	1
8	Dual Block®	POM	3
9	body	U-PVC	1
10*	support o-ring for ball seat	EPDM-FKM	4
11*	ball seat	PTFE	4
12	ball	U-PVC	1
13	radial seal o-ring	EPDM-FKM	3
14	support for ball seat	U-PVC	3
15	stop ring	U-PVC	3
16*	socket seal o-ring	EPDM-FKM	3
17*	end connector	U-PVC	3
18abc	union nuts	U-PVC	3

\* Spare parts available.

\*\* Optional feature

## TKD SERIES 3-WAY BALL VALVES

### Installation Procedures

1. For socket and threaded style connections, remove the union nuts (part #18 on previous page) and slide them onto the pipe. For flanged connections, remove the union nut / flange assemblies from the valve.
2. Please refer to the appropriate connection style sub-section:
  - a. For socket style, solvent cement the end connectors (17) onto the pipe ends. For correct joining procedure, please refer to the section entitled, *“Joining Methods – Solvent Cementing”* in the IPEX Industrial Technical Manual Series, *“Volume I: Vinyl Process Piping Systems”*. **Be sure to allow sufficient cure time before continuing with the valve installation.**
  - b. For threaded style, thread the end connectors (17) onto the pipe ends. For correct joining procedure, please refer to the section entitled, *“Joining Methods – Threading”* in the IPEX Industrial Technical Manual Series, *“Volume I: Vinyl Process Piping Systems”*.
  - c. For flanged style, join the union nut / flange assemblies to the pipe flanges. For correct joining procedure, please refer to the section entitled, *“Joining Methods – Flanging”* in the IPEX Industrial Technical Manual Series, *“Volume I: Vinyl Process Piping Systems”*.
3. Open and close the valve to ensure that the seat supports (14) are at the desired adjustment. If adjustment is required, remove the insert tool (1) from the handle (2). Line up the moldings on the tool with the slots in the seat supports. Tighten or loosen to the desired position then replace the tool on the handle. **For correct alignment of the ball and seat support system, adjustment should begin with the center port.**
4. Ensure that the socket o-rings (16) are properly fitted in their grooves then carefully place the valve in the system between the end connections. If anchoring is required, fix the valve to the supporting structure via the integral mounting flange on the bottom of the valve body (9).
5. Tighten the three union nuts. Hand tightening is typically sufficient to maintain a seal for the maximum working pressure. **Over-tightening may damage the threads on the valve body and/or the union nut, and may even cause the union nut to crack.**
6. Check the installation of the dedicated lock nut device DUAL BLOCK® (8) on the valve body.
7. Open and close the valve to ensure that the cycling performance is adequate. If adjustment is required, loosen the union nuts, remove the valve from the system, and then continue from Step 3.



## TKD SERIES 3-WAY BALL VALVES

## Valve Maintenance

## Disassembly

1. If removing the valve from an operating system, isolate the valve from the rest of the system. **Be sure to depressurize and drain the isolated branch and valve before continuing.**
2. Unlock the Dual Block® system by compressing the lever (8). Loosen the three union nuts (18) and drop the valve out of the line. If retaining the socket o-rings (16), take care that they are not lost when removing the valve from the line.
3. To disassemble, rotate the handle (2) to the following position:
  - a. For T-Port valves, the three arrows must line up with the three valve ports (The valve must be open at all three ports).
  - b. For L-Port valves, the two arrows must line up with ports "a" and "b" (see component diagram).
4. Remove the insert tool (1) from the handle then line up the moldings on the tool with the slots in the seat supports (14). Loosen and remove all three seat supports from the valve body (9).
5. Remove the ball (12) from the valve body while taking care not to score or damage the outer surface.
6. Remove the handle from the stem (7) by pulling upwards. To remove the stem, push it into the valve body from above.
7. Remove the seats (11), backing o-rings (10), and body o-rings (13) from the seat supports.
8. Remove the seat and backing o-ring from the inside of the valve body.
9. Remove the stem o-rings (5).
10. The valve components can now be checked for problems and/or replaced.

## Assembly

**Note:** Before assembling the valve components, it is advisable to lubricate the o-rings with a water soluble lubricant. **Be sure to consult the "IPEX Chemical Resistance Guide" and/or other trusted resources to determine specific lubricant-rubber compatibilities.**

1. Properly fit the stem o-rings (5) in the grooves on the stem (7), then insert the stem from the inside of the valve body (9).
2. Line up the markings on the stem with the ports in the valve body.
3. Replace the backing o-ring (10) and seat (11) at the back of the valve body.
4. Insert the ball (12) into the valve body while ensuring that the ports line up with the markings on the stem.
5. Ensure that all body o-rings (13), backing o-rings, and seats are properly fitted on the three seat supports (14). **Starting with the center port**, tighten each support into the valve body using the insert tool (1).
6. Replace the handle (2) on the stem while ensuring that the position markings on the handle line up with those on the stem. Replace the insert tool on the handle.
7. Properly fit the socket o-rings (16) in their respective grooves.
8. Place the end connectors (17) into the union nuts (18), then thread onto the valve body taking care that the socket o-rings remain properly fitted in their grooves.

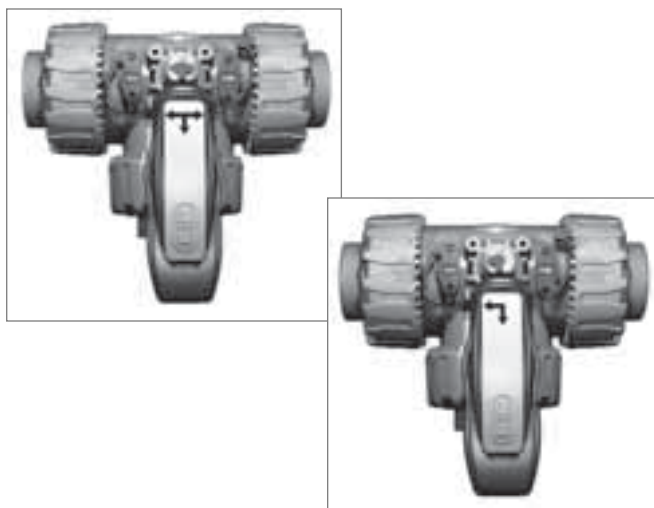

## VT SERIES 3-WAY BALL VALVES

IPEX VT Series 3-Way Ball Valves can be used for flow diverting, mixing, or on/off isolation. They will replace a Tee + 2 valve linkage assembly at reduced cost and space, along with shorter installation and maintenance time. Molded features on the body allow for simple mounting and actuation while in-line ball seat adjustments are easily achieved by tightening the union nuts. VT Series 3-Way Ball Valves are part of our complete Xirtec®140 and SFPP systems of pipe, valves, and fittings, engineered and manufactured to our strict quality, performance, and dimensional standards.

### Valve Availability

Body Material:	PVC, PP
Size Range:	1/2" through 2"
Pressure:	150psi
Seats:	Teflon® (PTFE)
Seals:	EPDM or Viton® (FPM)
End Connections:	Socket (IPS) Threaded (FNPT) Socket (Metric)



ASTM D1784  
ASTM D2464  
ASTM D2466  
ASTM D2467  
ASTM D4101  
ASTM F1498



ANSI B1.20.1



ISO 11922-1



## VT SERIES 3-WAY BALL VALVES

### Sample Specification

#### 1.0 Ball Valves - VT

##### 1.1 Material

- The valve body, stem, ball, end connectors, and unions shall be made of PVC compound which shall meet or exceed the requirements of cell classification 12454 according to ASTM D1784.
- or The valve body, stem, ball, end connectors, and unions shall be made of stabilized PP homopolymer compound, also containing a RAL 7032 pigment, which shall meet or exceed the requirements of Type I Polypropylene according to ASTM D4101.

##### 1.2 Seats

- The ball seats shall be made of Teflon® (PTFE).

##### 1.3 Seals

- The o-ring seals shall be made of EPDM.
- or The o-ring seals shall be made of Viton® (FPM).

- 1.4 All wetted parts of the valves shall comply with standards that are equivalent to NSF Standard 61 for potable water.

#### 2.0 Connections

##### 2.1 Socket style

- The IPS socket PVC end connectors shall conform to the dimensional standards ASTM D2466 and ASTM D2467.
- or The Metric socket PP end connectors shall conform to the dimensional standard ISO 11922-1.

##### 2.2 Threaded style

- The female NPT threaded PVC end connectors shall conform to the dimensional standards ASTM D2464, ASTM F1498, and ANSI B1.20.1.
- or The female NPT threaded PP end connectors shall conform to the dimensional standards ASTM F1498, and ANSI B1.20.1.

##### 3.0 Design Features

- All valves shall be true union at all three ports.
- All sizes shall be full port.
- Valve design shall permit positive shutoff of any of the three ports.
- Balls shall be of T-port or L-port design (specifier must select one).
- The valve body, union nuts, and carrier shall have deep square style threads for increased strength.
- The ball shall be machined smooth to minimize wear on valve seats.
- All valve seats shall have o-ring backing cushions to compensate for wear and prevent seizure of the ball.
- The thickness of the valve body shall be the same at all three ports.
- The handle shall incorporate molded features to indicate port location and ball position.
- The top of the stem shall incorporate molded features to indicate port location and ball position.
- All valves shall have integrally molded mounting pads.

##### 3.1 Pressure Rating

- All valves shall be rated at 150psi at 73°F (23°C).

##### 3.2 Markings

- All valves shall be marked to indicate size, material designation, and manufacturers name or trade mark.

##### 3.3 Color Coding

- All PVC valves shall be color-coded dark gray.
- or All PP valves shall be color-coded beige gray.

- 4.0 All valves shall be Xirtec®140 or PP by IPEX or approved equal.

## VT SERIES 3-WAY BALL VALVES

### Dimensions

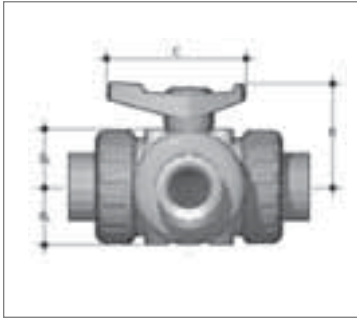

Dimension (inches)				
Size	d	B	C	B1
1/2	0.84	2.01	2.56	1.08
3/4	1.05	2.36	2.99	1.28
1	1.32	2.64	3.35	1.44
1-1/4	1.66	2.95	3.94	1.69
1-1/2	1.90	3.50	4.41	2.03
2	2.38	4.13	5.39	2.34

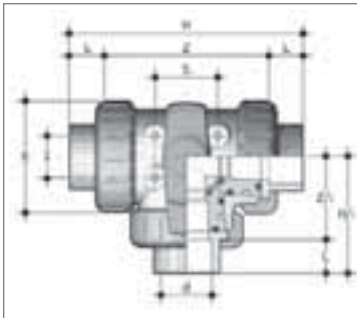

IPS Socket Connections - Dimension (inches)							
Size	d	L	Z	H	E	I1	I
1/2	0.84	0.89	3.03	4.80	2.09	0.94	0.94
3/4	1.05	1.00	3.58	5.59	2.44	1.22	0.98
1	1.32	1.13	3.96	6.22	2.80	1.57	1.06
1-1/4	1.66	1.26	4.92	7.44	3.31	1.61	1.26
1-1/2	1.90	1.38	5.31	8.07	3.86	2.09	1.10
2	2.38	1.50	6.56	9.57	4.61	2.28	1.38

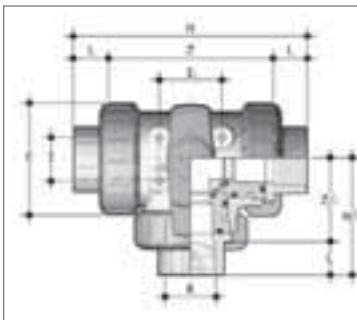

Female NPT Threaded Connections - Dimension (inches)							
Size	R	L	Z	H	E	I1	I
1/2	1/2-NPT	0.70	3.17	4.57	2.09	0.94	0.94
3/4	3/4-NPT	0.71	3.69	5.10	2.44	1.22	0.98
1	1-NPT	0.89	4.15	5.93	2.80	1.57	1.06
1-1/4	1-1/4-NPT	0.99	5.12	7.09	3.31	1.61	1.26
1-1/2	1-1/2-NPT	0.97	5.50	7.44	3.86	2.09	1.10
2	2-NPT	1.17	6.73	9.06	4.61	2.28	1.38

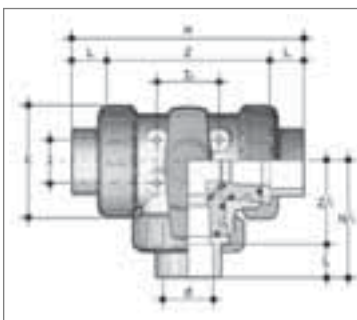

Metric Socket Connections - Dimension (inches)							
Size	d	L	Z	H	E	I1	I
20mm	0.79	0.57	3.23	4.37	2.09	0.93	0.93
25mm	0.98	0.63	3.74	5.00	2.48	1.20	0.96
32mm	1.26	0.71	4.29	5.71	2.80	1.55	1.04
40mm	1.57	0.81	5.12	6.73	3.31	1.58	1.24
50mm	1.97	0.93	6.10	7.95	3.82	2.05	1.10
63mm	2.48	1.08	7.20	9.37	4.57	2.22	1.34

**BALL VALVES**

## VT SERIES 3-WAY BALL VALVES

### Weights

Size	Approximate Weight (lbs)		
	PVC		PP
	IPS Socket	FNPT Threaded	Metric Socket
1/2	0.54	0.53	0.39
3/4	0.85	0.80	0.60
1	1.23	1.25	0.88
1-1/4	1.93	1.86	1.36
1-1/2	2.84	2.73	1.90
2	4.60	4.41	3.09

### Flow Coefficients

Size	C <sub>v</sub>				
	Position				
	A	B	C	D	E
1/2	3.85	2.45	4.55	13.7	5.11
3/4	9.50	6.65	10.2	26.6	10.5
1	14.4	9.80	17.2	53.2	18.6
1-1/4	27.3	18.9	32.2	73.5	33.3
1-1/2	33.3	23.1	42.0	119	43.4
2	63.0	43.4	84.0	224	85.4

BALL VALVES

### Pressure - Temperature Ratings

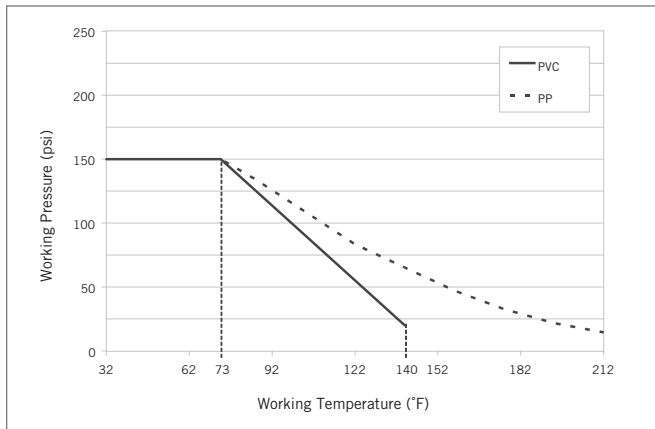

## VT SERIES 3-WAY BALL VALVES

### Operating Positions

Position	T-Port	L-Port
0°	mixing	diverting
90°	diverting	closed
180°	straight flow	closed
270°	diverting	diverting

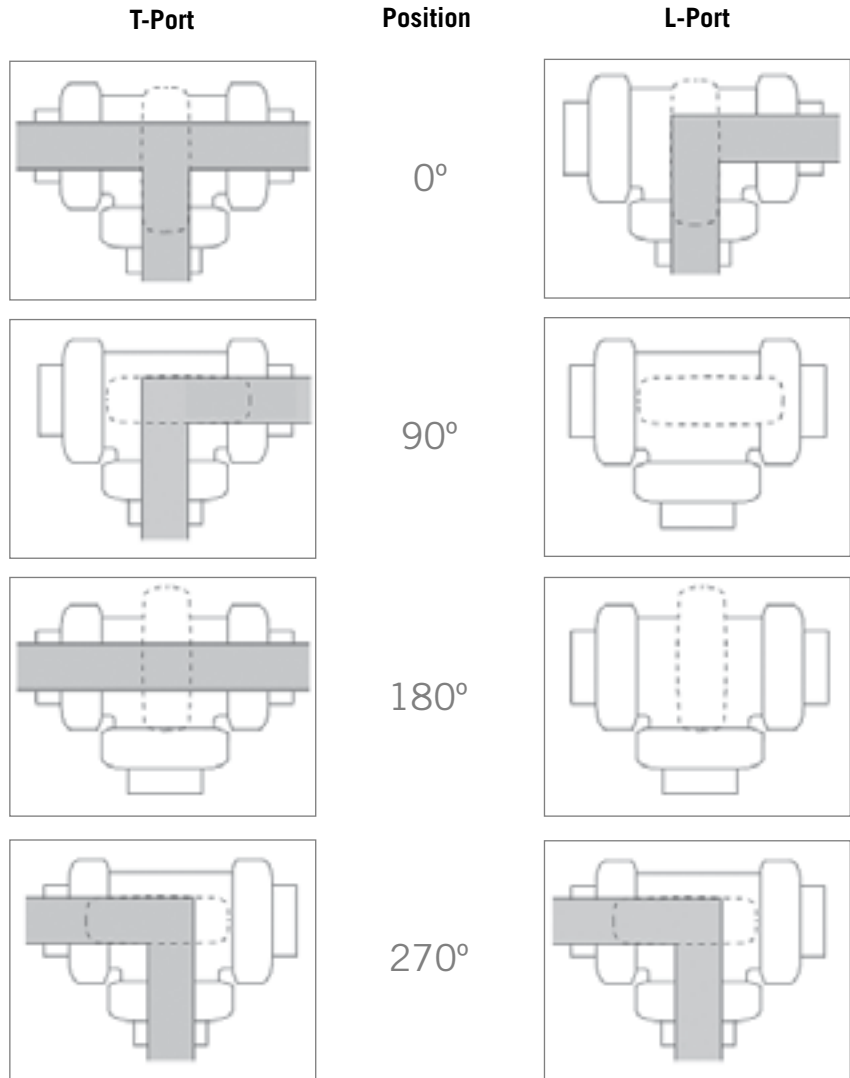

BALL VALVES

## VT SERIES 3-WAY BALL VALVES

### Pressure Loss Charts

#### Position A:

- T-Port
- Center Inlet
- Diverting Flow

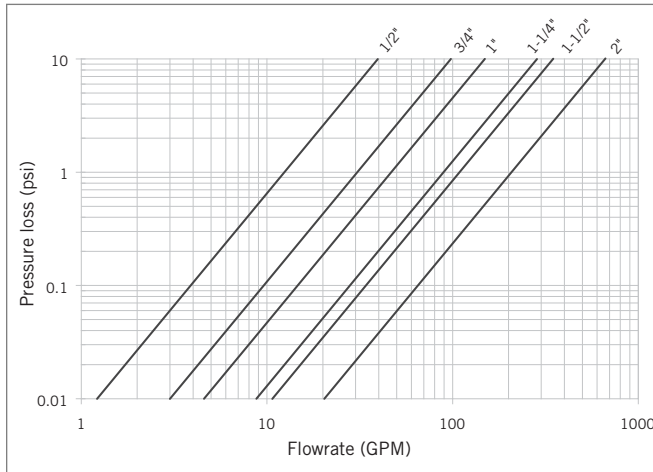
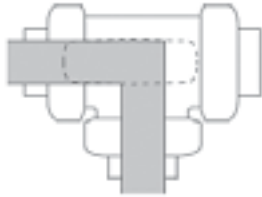

#### Position B:

- T-Port
- Center Inlet
- Separating Flow

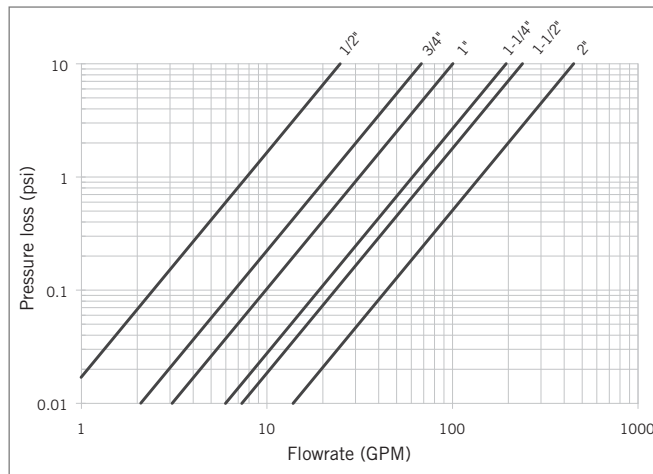
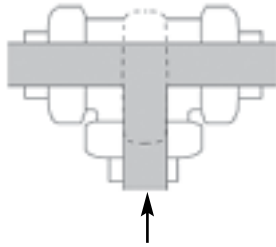

#### Position C:

- T-Port
- Side Inlet
- Diverting Flow

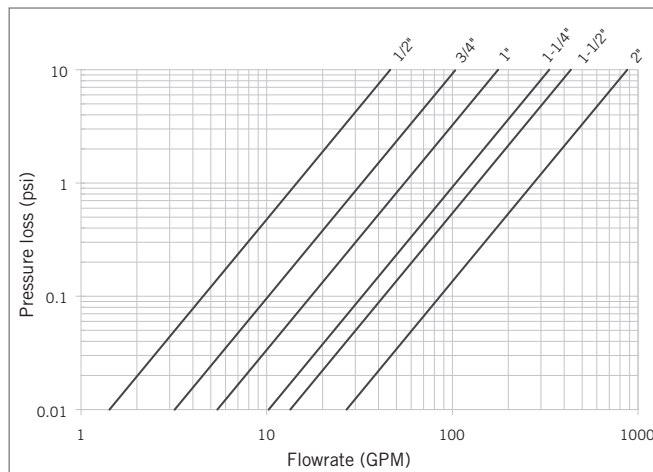
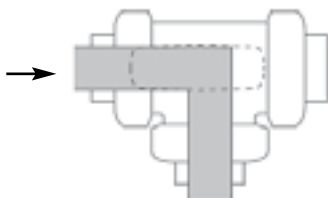

## VT SERIES 3-WAY BALL VALVES

### Pressure Loss Charts (cont'd)

Position D:

- T-Port
- Side Inlet
- Straight Flow

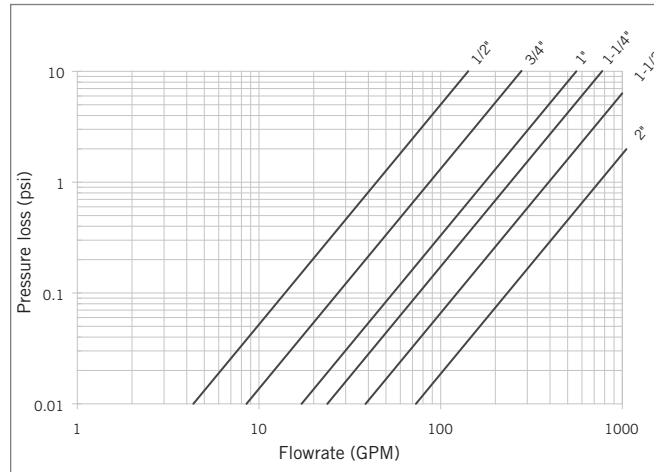
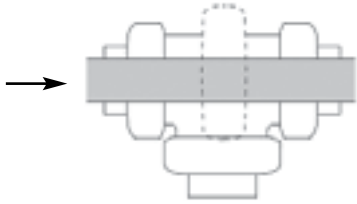

Position E:

- L-Port
- Any Inlet
- Diverting Flow

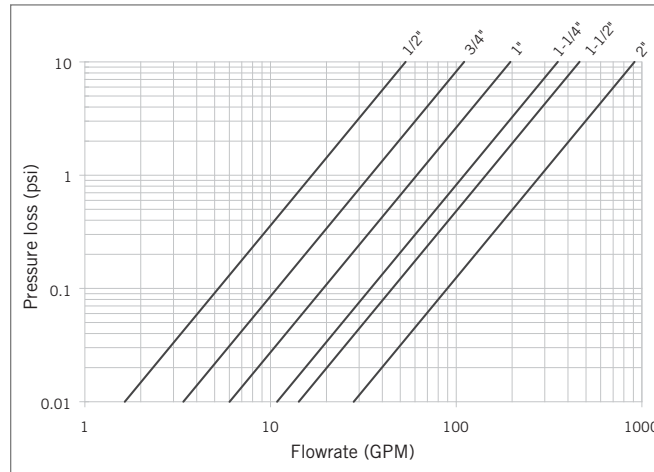
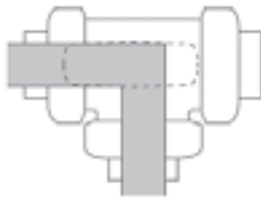

## VT SERIES 3-WAY BALL VALVES

### Components

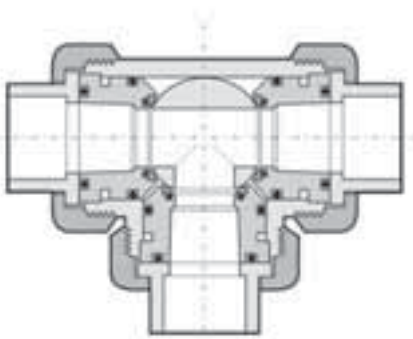
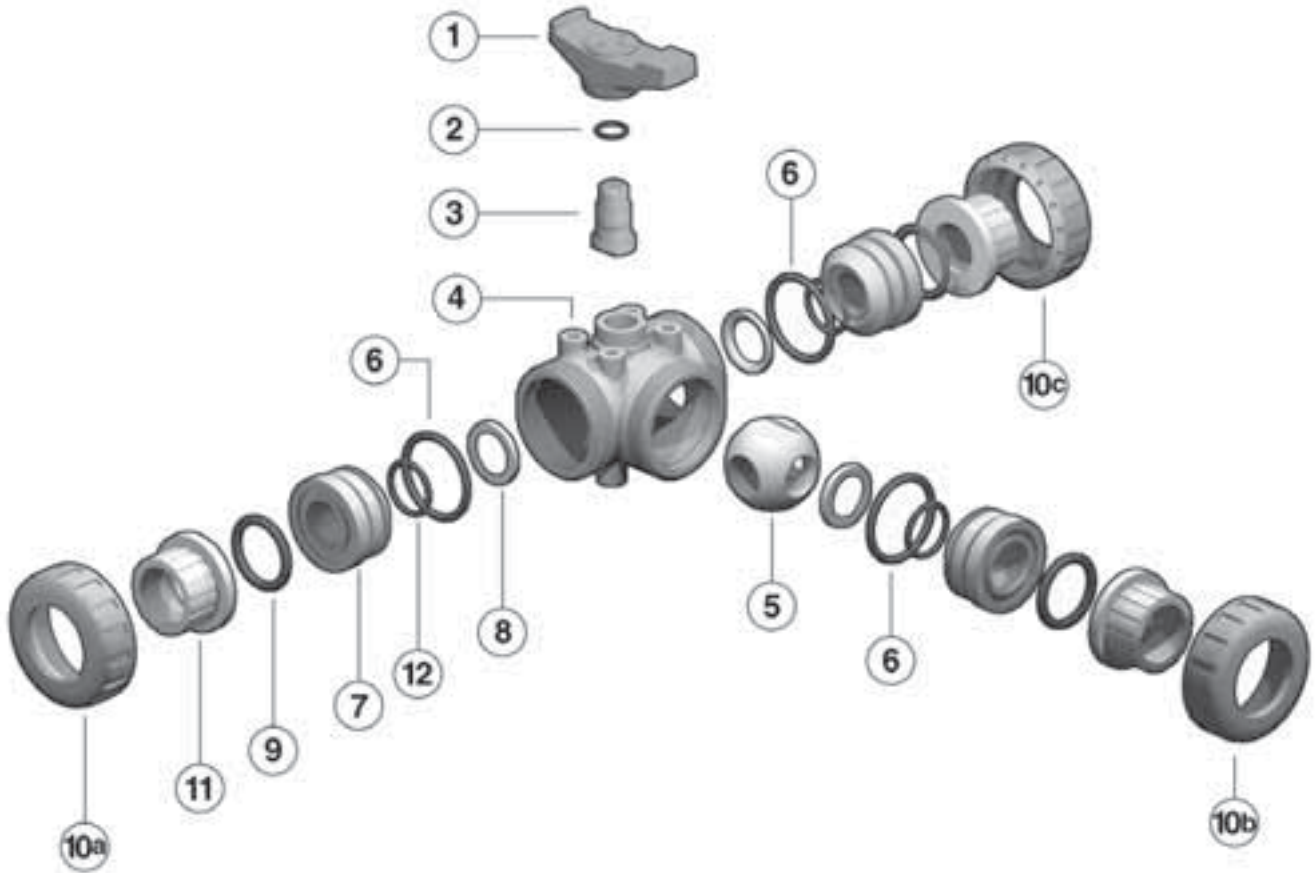

#	Component	Material	Qty
1*	handle	High Impact PVC	1
2*	stem o-ring	EPDM or Viton®	1
3*	stem	PVC / PP	1
4	body	PVC / PP	1
5*	ball	PVC / PP	1
6*	body o-ring	EPDM or Viton®	3
7	support for ball seat	PVC / PP	3
8*	ball seat	PTFE	3
9*	socket o-ring	EPDM or Viton®	3
10*	union nut	PVC / PP	3
11*	end connector	PVC / PP	3
12	backing o-ring	EPDM or Viton®	3

\* Spare parts available.

## VT SERIES 3-WAY BALL VALVES

### Installation Procedures

1. For socket and threaded style connections, remove the union nuts (part #10 on previous page) and slide them onto the pipe. For flanged connections, remove the union nut / flange assemblies from the valve.
2. Please refer to the appropriate connection style sub-section:
  - a. For socket style, solvent cement the end connectors (11) onto the pipe ends. For correct joining procedure, please refer to the section entitled, *“Joining Methods – Solvent Cementing”* in the IPEX Industrial Technical Manual Series, *“Volume I: Vinyl Process Piping Systems”*. **Be sure to allow sufficient cure time before continuing with the valve installation.**
  - b. For threaded style, thread the end connectors (11) onto the pipe ends. For correct joining procedure, please refer to the section entitled, *“Joining Methods – Threading”* in the IPEX Industrial Technical Manual Series, *“Volume I: Vinyl Process Piping Systems”*.
3. Ensure that the socket o-rings (9) are properly fitted in their grooves then carefully place the valve in the system between the end connections.
4. Tighten the union nut on the side marked “TIGHTEN” (10a). Hand tightening is typically sufficient to maintain a seal for the maximum working pressure. Over-tightening may damage the threads on the valve body and/or the union nut, and may even cause the union nut to crack.
5. Tighten the remaining two union nuts (10b and 10c). Tightening the union nuts in this order results in the best possible valve performance due to optimum positioning and sealing of the ball and seat support system.
6. Open and close the valve to ensure that the cycling performance is adequate. If adjustment is required, loosen and/or tighten only the 10b and 10c union nuts.

## VT SERIES 3-WAY BALL VALVES

### Valve Maintenance

#### Disassembly

1. If removing the valve from an operating system, isolate the valve from the rest of the system. **Be sure to depressurize and drain the isolated branch and valve before continuing.**
2. Loosen the three union nuts (10) and drop the valve out of the line. If retaining the socket o-rings (9), take care that they are not lost when removing the valve from the line.
3. To disassemble, turn the handle (1) to a position parallel with the two side ports of the valve body (4).
4. Carefully press the ball (5) and support (7) out of the valve body from one of the side ports, taking care not to score or damage the sealing surfaces.
5. Remove the remaining two seat supports from the valve body.
6. Remove the handle (1) from the stem (3). Press the stem into the valve body from above to remove.
7. The stem o-ring (2), body o-rings (6), ball seats (8), and backing o-rings (12) can now be removed and/or replaced.



#### Assembly

**Note:** Before assembling the valve components, it is advisable to lubricate the o-rings with a water soluble lubricant. **Be sure to consult the “IPEX Chemical Resistance Guide” and/or other trusted resources to determine specific lubricant-rubber compatibilities.**

1. Properly fit the stem o-ring (2) in the groove on the stem (3), then insert the stem from the inside of the valve body (4).
2. Line up the markings on the stem with the ports in the valve body.
3. Insert the ball (5) into the valve body while ensuring that the ports line up with the markings on the stem.
4. Ensure that the backing o-rings (12), ball seats (8), and body o-rings (6) are all properly fitted on the three seat supports (7) then carefully insert each of them into the valve body.
5. Replace the handle (1) on the stem while ensuring that the position markings on the handle line up with those on the stem.
6. Properly fit the socket o-rings (9) in their respective grooves.
7. Place the end connectors (11) into the union nuts (10), then thread onto the valve body taking care that the socket o-rings remain properly fitted in their grooves.



## SECTION THREE: BUTTERFLY VALVES

### FK SERIES BUTTERFLY VALVES

IPEX FK Series Butterfly Valves offer superior strength and chemical resistance in highly corrosive environments and process flow conditions. The special trapezoid shape of the liner and a serrated body cavity guarantee a bubble tight seal while keeping break-away torque at an absolute minimum. This versatile industrial valve features double self-lubricating seals, direct actuator mount capability, and the option of either a lever handle or mounted gear box. A special integral stainless steel lug version provides for full bi-directional operation allowing disassembly of the downstream flange connection without weakening the integrity of the upstream connection to the pressurized line. FK Series Butterfly Valves are part of our complete Xirtec®140, Corzan® and SFPP systems of pipe, valves, and fittings, engineered and manufactured to our strict quality, performance, and dimensional standards.

#### Valve Availability

Body Material:	Glass reinforced PP (GRPP)
Disc Material:	PP, PVC, CPVC, PVDF
Size Range:	1-1/2" through 12"
Pressure:	150psi (1-1/2" to 10") 120psi (12")
Seats:	EPDM or Viton® (FPM)
Seals:	EPDM or Viton® (FPM)
Body Style:	Wafer or Lugged
Control Style:	Lever Handle or Mounted Gear Box
End Connections:	Flanged (ANSI 150)



ASTM D1784  
ASTM D3222  
ASTM D4101



ANSI B16.5



## FK SERIES BUTTERFLY VALVES

**Sample Specification****1.0 Butterfly Valves - FK****1.1 Material**

- The valve body shall be made of glass reinforced polypropylene (GRPP) obtained from homopolymer polypropylene (PPH).
- The valve disc shall be made of stabilized PP homopolymer compound, also containing a RAL 7032 pigment, which shall meet or exceed the requirements of Type I Polypropylene according to ASTM D4101.
- or The valve disc shall be made of PVC compound which shall meet or exceed the requirements of cell classification 12454 according to ASTM D1784.
- or The valve disc shall be made of Corzan® CPVC compound which shall meet or exceed the requirements of cell classification 23447 according to ASTM D1784.
- or The valve disc shall be made of virgin, non-regrind PVDF compound which shall meet or exceed the requirements of Table 1 according to ASTM D3222.
- The valve shaft shall be made of 420 stainless steel.

**1.2 Seats**

- The disc liner shall be made of EPDM.
- or The disc liner shall be made of Viton® (FPM).

**1.3 Seals**

- The o-ring seals shall be made of EPDM.
- or The o-ring seals shall be made of Viton® (FPM).

**1.4** All wetted parts of the valves shall comply with standards that are equivalent to NSF Standard 61 for potable water.

**2.0 Connections****2.1 Flanged style**

- The ANSI 150 flanged connections shall conform to the dimensional standard ANSI B16.5.

**3.0 Design Features**

- The valve shall be of either wafer or lugged design (specifier must select one).
- The lugged style shall feature permanently integrated stainless steel lugs. No field inserted lugs allowed.
- Manual control of the valve shall be achieved through the use of either a lever handle or mounted gear box (specifier must select one).
- The shaft shall have standard ISO square dimensions for direct mounting of actuators.
- The disc seat shall be a trapezoidal elastomeric liner and provide a bubble tight seal.
- The liner shall completely isolate the valve body from the process flow.
- The liner shall function as a flange gasket on both sides of the valve.
- The body cavity shall feature special channeling to prevent liner slippage and compression.
- The disc, seats, and seals shall be the only wetted parts.
- Teflon® seated o-ring seals shall prevent the stainless steel shaft from becoming wetted.

**3.1 Pressure Rating**

- Valve sizes 1-1/2" through 10" shall be rated at 150psi at 73°F (23°C).
- Valve sizes 12" shall be rated at 120psi at 73°F (23°C).

**3.2 Markings**

- All valves shall be marked to indicate size, material designation, and manufacturers name or trade mark.

**3.3 Color Coding**

- All valves shall be color-coded beige gray.

**4.0** All valves shall be by IPEX or approved equal.

## FK SERIES BUTTERFLY VALVES

### Dimensions

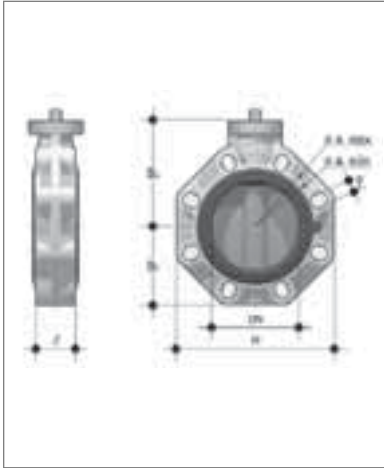

Dimension (inches)									
Size	DN	Z	B1	B2	H	A <sub>min</sub>	A <sub>max</sub>	f	# holes
1-1/2	1.57	1.30	4.17	2.36	5.20	3.90	4.29	0.75	4
2	1.97	1.69	4.41	2.76	5.79	4.53	4.94	0.75	4
2-1/2	2.56	1.81	4.69	3.15	6.50	5.04	5.67	0.75	4
3	3.15	1.93	5.24	3.66	7.28	5.71	6.30	0.75	8
4	3.94	2.20	5.79	4.21	8.31	6.50	7.48	0.75	8
5	4.92	2.52	6.57	4.72	9.45	8.03	8.46	0.91	8
6	5.91	2.76	7.09	5.28	10.55	9.06	9.53	0.91	8
8	7.87	2.80	8.94	6.34	12.72	11.02	11.73	0.91	8
10	9.84	4.49	9.76	8.27	15.94	13.19	14.25	1.00	12
12	11.81	4.49	12.01	9.65	18.70	15.35	17.01	1.14	12

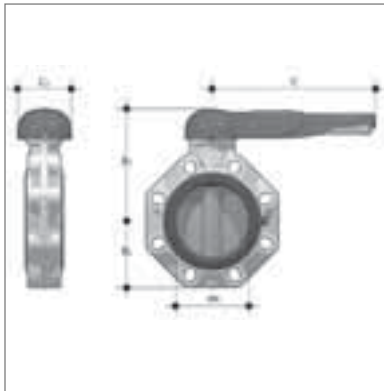

Lever Handle - Dimension (inches)						
Size	DN	C1	C	B2	B3	# holes
1-1/2	1.57	3.94	6.89	2.36	5.39	4
2	1.97	3.94	6.89	2.76	5.63	4
2-1/2	2.56	4.33	10.71	3.15	6.46	4
3	3.15	4.33	10.71	3.66	7.01	8
4	3.94	4.33	10.71	4.21	7.56	8
5	4.92	4.33	12.99	4.72	8.35	8
6	5.91	4.33	12.99	5.28	8.86	8
8	7.87	4.80	16.54	6.34	10.71	8

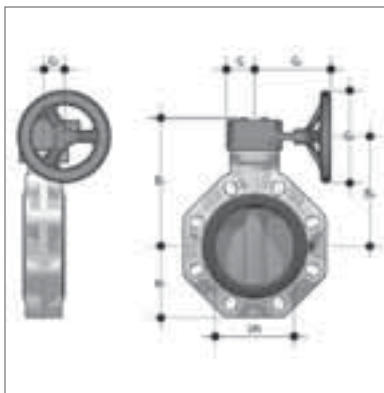

Mounted Gear Box - Dimension (inches)									
Size	DN	G2	G	G1	G3	B2	B5	B6	# holes
2-1/2	2.56	1.54	1.89	5.31	4.92	3.15	6.85	5.75	4
3	3.15	1.54	1.89	5.31	4.92	3.66	7.40	6.30	8
4	3.94	1.54	1.89	5.31	4.92	4.21	7.95	6.85	8
5	4.92	1.54	1.89	5.67	7.87	4.72	8.74	7.64	8
6	5.91	1.54	1.89	5.67	7.87	5.28	9.25	8.15	8
8	7.87	2.36	2.56	8.03	7.87	6.34	11.30	10.08	8
10	9.84	2.99	3.46	9.29	9.84	8.27	12.48	11.06	12
12	11.81	2.99	3.46	9.29	9.84	9.65	14.72	13.31	12

## FK SERIES BUTTERFLY VALVES

### Dimensions (cont'd)

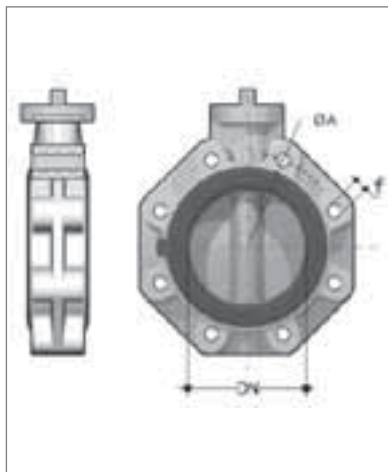

ANSI Lugged - Dimension (inches)				
Size	DN	A	f	# holes
1-1/2	1.57	3.87	1/2 - UNC	4
2	1.97	4.75	5/8 - UNC	4
2-1/2	2.56	5.50	5/8 - UNC	4
3	3.15	6.00	5/8 - UNC	8
4	3.94	7.50	5/8 - UNC	8
5	4.92	8.50	3/4 - UNC	8
6	5.91	9.50	3/4 - UNC	8
8	7.87	11.75	3/4 - UNC	8
10	9.84	14.25	7/8 - UNC	12
12	11.81	17.00	7/8 - UNC	12

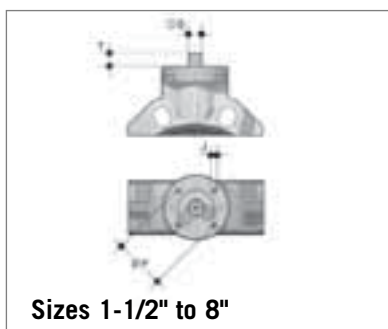

Sizes 1-1/2" to 8"

Mounting Pad for Actuation - Dimension (inches)					
Size	ISO	J	P	T	Q
1-1/2	F05	0.28	1.97	0.47	0.43
2	F05	0.28	1.97	0.47	0.43
2-1/2	F05 / F07	0.28 / 0.35	1.97 / 2.76	0.47	0.43
3	F07	0.35	2.76	0.63	0.55
4	F07	0.35	2.76	0.63	0.55
5	F07	0.35	2.76	0.75	0.67
6	F07	0.35	2.76	0.75	0.67
8	F10	0.43	4.02	0.94	0.87
10	F10 / F12 / F14	0.43 / 0.51 / 0.67	4.02 / 4.92 / 5.51	1.14	1.06
12	F10 / F12 / F14	0.43 / 0.51 / 0.67	4.02 / 4.92 / 5.51	1.14	1.06

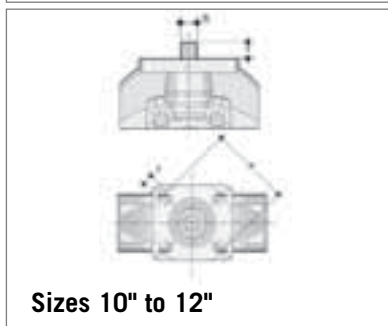

Sizes 10" to 12"

### Weights

Size	Approximate Weight (lbs)		
	Valve	w/ Handle	w/ Gear Box
1-1/2	1.27	1.98	-
2	1.66	2.38	-
2-1/2	2.20	3.24	5.29
3	3.09	4.12	6.17
4	3.86	4.89	6.94
5	5.62	6.83	9.81
6	7.28	8.49	11.46
8	13.23	14.88	20.50
10	26.46	-	41.01
12	41.89	-	56.44

## FK SERIES BUTTERFLY VALVES

### Pressure – Temperature Ratings

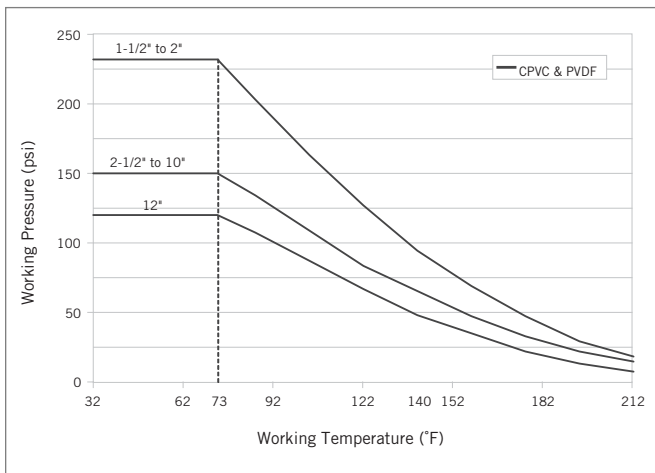
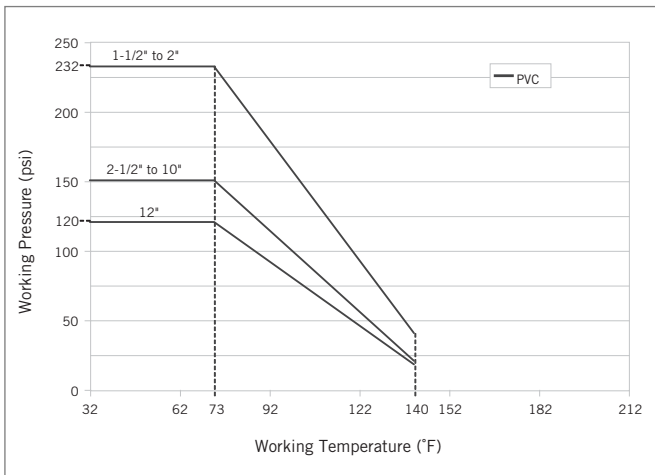
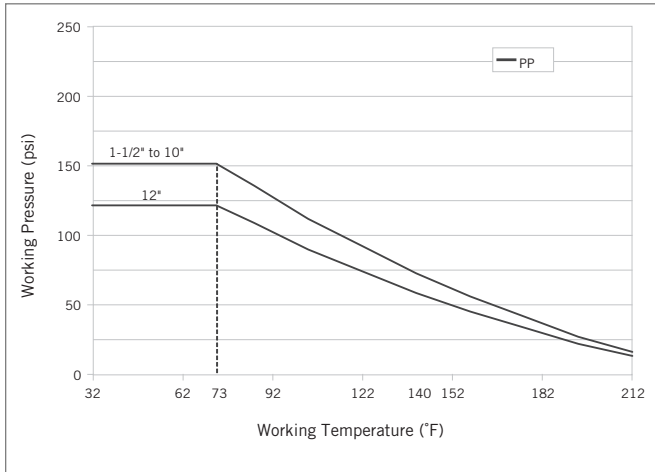

### Flow Coefficients

Size	Cv
1-1/2	70
2	90
2-1/2	119
3	249
4	413
5	690
6	1309
8	2135
10	3724
12	5712

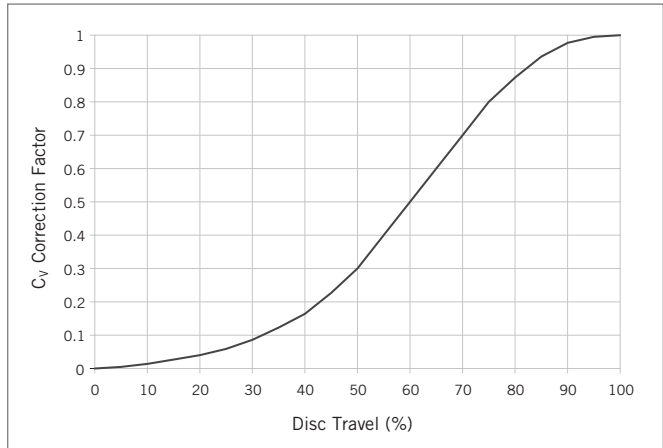

### Pressure Loss Chart

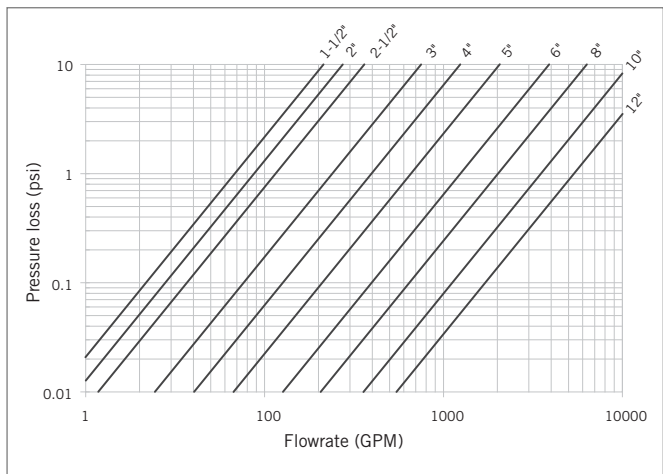

**Note:** FK lugged butterfly valves in end-of-line applications are rated to full pressures – no de-rating is necessary.

BUTTERFLY VALVES

## FK SERIES BUTTERFLY VALVES

### Components

Sizes 1-1/2" to 2"

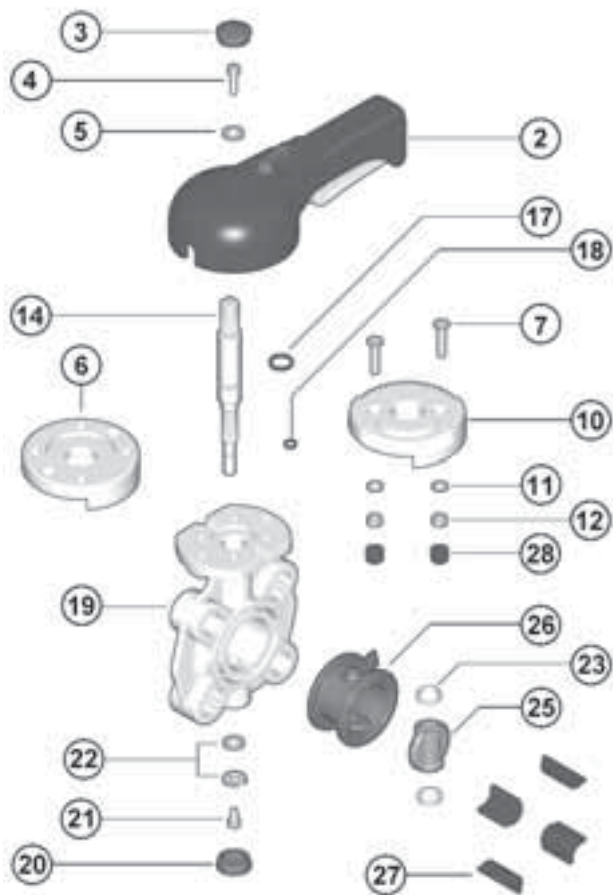

Sizes 2-1/2" to 8"

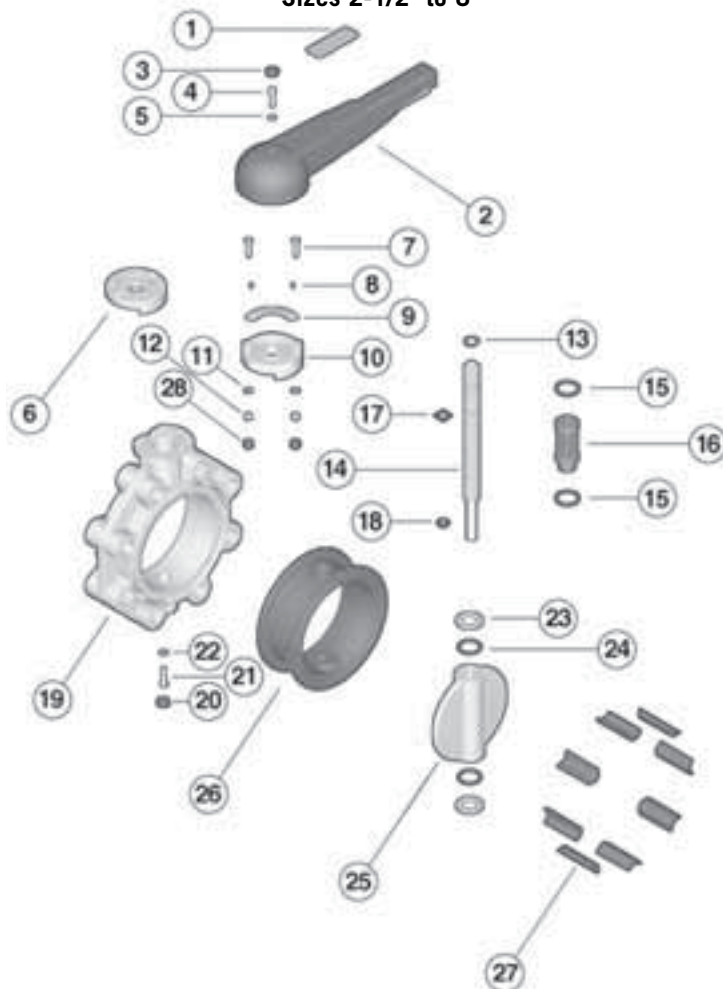

BUTTERFLY VALVES

#	Component	Material	Qty
1*	handle insert	ABS	1
2*	handle	PVC	1
3*	cap	PE	1
4*	screw	SS	1
5*	washer	SS	1
6	spacer pad	GRPP	1
7	screw	SS	2
8	screw	SS	2
9	ratchet	SS	1
10	pad	GRPP	1
11	washer	SS	2
12	nut	SS	2
13	retaining ring	SS	1
14*	shaft	420 SS	1

#	Component	Material	Qty
15*	bushing o-ring	EPDM or Viton®	2
16	bushing	Nylon	1
17*	shaft o-ring	EPDM or Viton®	1
18*	shaft o-ring	EPDM or Viton®	1
19	body	GRPP	1
20	cap	PE	1
21	screw	SS	1
22	washer	SS	1
23*	anti-friction ring	PTFE	2
24*	disc o-ring	EPDM or Viton®	2
25*	disc	PP / PVC / CPVC / PVDF	1
26*	primary liner	EPDM or Viton®	1
27	inserts	ABS	4 or 8
28	cap	PE	2

\* Spare parts available.

## FK SERIES BUTTERFLY VALVES

### Components (cont'd)

Sizes 10" to 12"

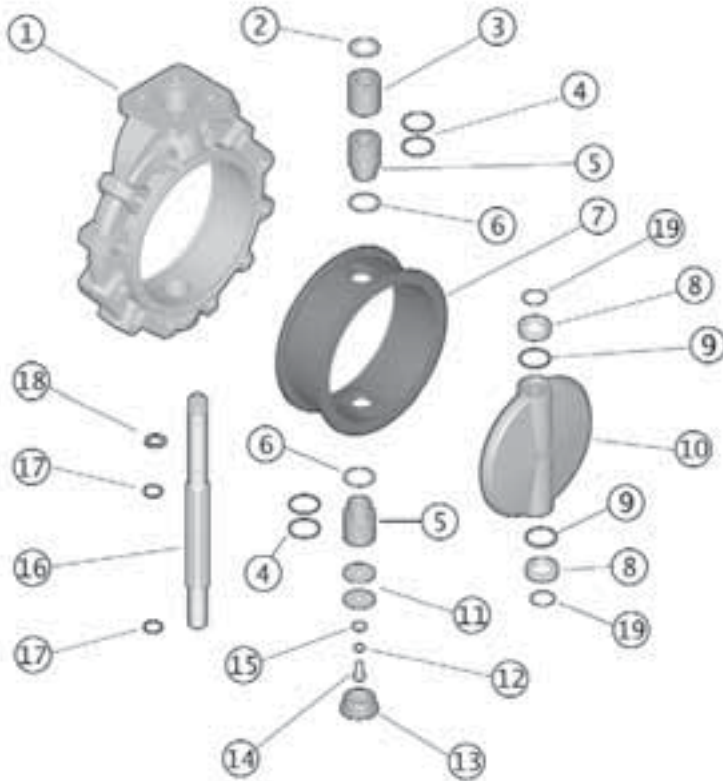

Infinite Adjustable Handle Kit

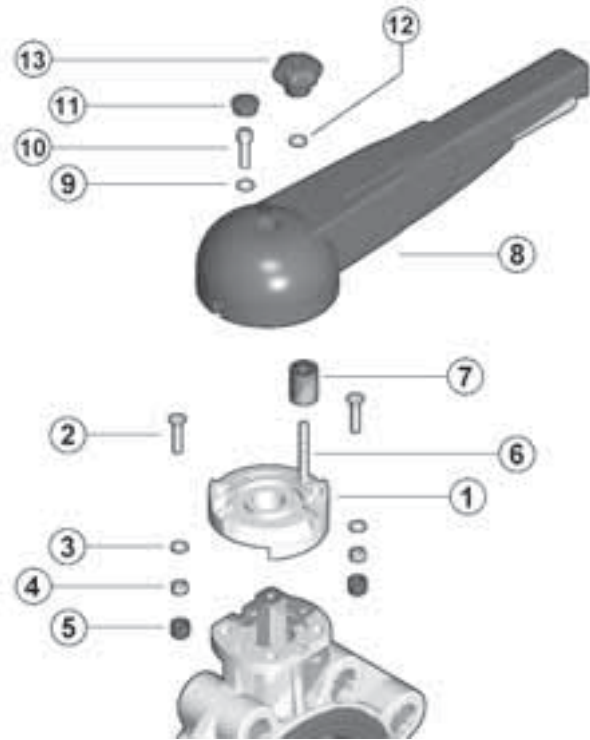

BUTTERFLY VALVES

#	Component	Material	Qty
1	body	GRPP	1
2	washer	SS	1
3	bushing	PP	1
4*	bushing o-ring	EPDM or Viton®	4
3	bushing for o-ring	PP	2
6	washer	PTFE	2
7*	primary liner	EPDM or Viton®	1
8*	anti-friction ring	PTFE	2
9*	disc o-ring	EPDM or Viton®	2
10*	disc	PP / PVC / CPVC / PVDF	1
11	washer	SS	2
12	washer	SS	1
13	cap	PE	1
14	screw	SS	1
15	washer	SS	1
16*	shaft	420 SS	1
17*	shaft o-ring	EPDM or Viton®	2
18	retaining ring	SS	1
19	o-ring	EPDM or Viton®	2

#	Component	Material	Qty
1	pad	GRPP	1
2	screw	SS	2
3	washer	SS	2
4	nut	SS	2
5	cap	PE	2
6	screw	SS	1
7	spacer	PVC	1
8	handle	PVC	1
9	washer	SS	1
10	screw	SS	1
11	cap	PE	1
12	washer	SS	1
13	knob	PP	1

\* Spare parts available.

## FK SERIES BUTTERFLY VALVES

### Installation Procedures

1. For the lever handle style, attach the handle (part #2 on previous pages) to the valve body (19) using the supplied bolt (4) and washer (5). Affix the cap (3) over the bolt.
2. For non-lugged style sizes 1-1/2" through 8", push the inserts (27) into the body holes according to the position chart below.
3. Ensure that the length of the bolts is sufficient for the size of valve being installed. Due to the varying designs of plastic flanges, there is no recommended minimum length. However, a length that results in at least 5 exposed threads on each side should be sufficient.
4. Please refer to the appropriate application sub-section:
  - a. For typical inline installation, ensure that the disc is in the partially closed position then carefully insert the valve into the piping system between the two flanges. Insert the bolts, washers, and nuts (if necessary), then hand tighten. Take care to properly line up the valve and flanges as any misalignment may cause leakage.
  - b. For lugged version end of line installation, ensure that the disc is in the partially closed position then carefully position the valve on the flange. Insert the bolts, and washers, then hand tighten. Take care to properly line up the valve and flange as any misalignment may cause leakage.
5. To avoid damage to the primary gasket, cycle the valve to the open position before tightening the bolts. For correct joining procedure, please refer to the section entitled, "Joining Methods – Flanging" in the IPEX Industrial Technical Manual Series, "Volume I: Vinyl Process Piping Systems". **The bolts should be tightened in an even pattern to the nominal torque in the table below.** These torque ratings are sufficient to maintain a watertight seal at the maximum rated operating pressure.

**Note:** If the process media is dirty or contains suspended particles, it is advisable to install the valve in an orientation in which the shaft is not vertical (see diagrams). Over time, particles may collect at the bottom of the valve posing a threat to the seal between the disc, liner, and shaft.

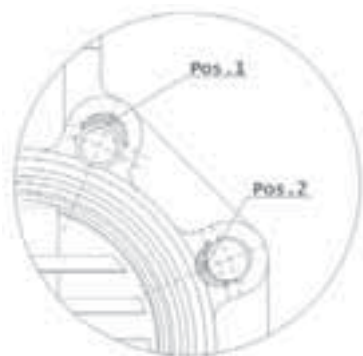
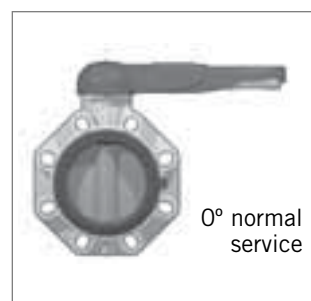
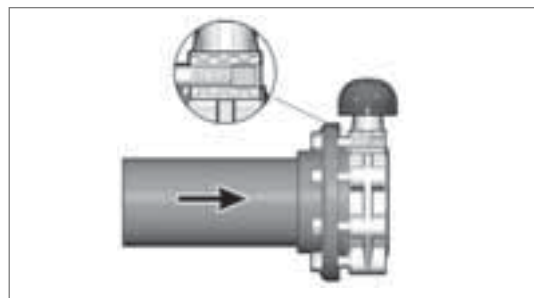
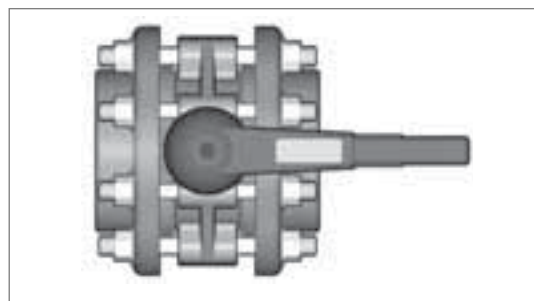

Size	ANSI 150 Insert Position	Nominal Bolt Torque (ft-lbs)
1-1/2	POS 1	7
2	-	9
2-1/2	POS 2	11
3	POS 2	13
4	POS 2	15
5	POS 2	26
6	POS 2	30
8	POS 2	41
10	-	52
12	-	52

## FK SERIES BUTTERFLY VALVES

### Valve Maintenance

#### Disassembly

1. If removing the valve from an operating system, isolate the valve from the rest of the system. **Be sure to depressurize and drain the isolated branch before continuing.**
2. Cycle the valve to a partially open position then loosen each bolt holding the valve to the pipe flange(s). Please refer to the section entitled, “*Joining Methods – Flanging*” in the IPEX Industrial Technical Manual Series, “*Volume I: Vinyl Process Piping Systems*” for a recommended bolt tightening pattern diagram. Follow the same pattern when disassembling the flanged joint(s) then carefully remove the valve from the line.



#### Sizes 1-1/2" to 8":

3. For the lever handle style:
  - a. Remove the cap (3) then loosen the screw (4) and washer (5) to remove the handle (2).
  - b. Loosen the screws (7) then remove the washers (11), nuts (12), caps (28), and the pad (10) from the valve body (19).
4. For the mounted gear box style:
  - a. Loosen and remove the bolts and washers fixed to the gear box. Carefully remove the gear box from the valve taking care not to damage the stem.
  - b. Loosen the screws (7) then remove the washers (11), nuts (12), caps (28), and the spacer pad (6) from the valve body (19).
5. Remove the cap (20) then loosen and remove the screw (21) and washer (22) from the base of the valve body.
6. Carefully pull the shaft (14) out of the valve body then remove the disc (25).
7. Remove the primary liner (26) from the valve body.
8. Remove the nylon bushing (16) and o-rings (15) from the valve body (sizes 2-1/2" to 8").
9. Remove the disc anti-friction rings (23), and o-rings (24, sizes 2-1/2" to 8").
10. Remove the retaining ring (13, sizes 2-1/2" to 8") and o-rings (17, 18) from the shaft.
11. The valve components can now be checked for problems and/or replaced.

#### Sizes 10" to 12":

3. Loosen and remove the bolts and washers fixed to the gear box. Carefully remove the gear box from the valve taking care not to damage the stem.
4. Remove the cap (13) then loosen and remove the screw (14) and washers (11, 12, and 15) from the base of the valve body (1).
5. Carefully pull the shaft (16) out of the valve body then remove the disc (10).
6. Remove the primary liner (7) from the valve body.
7. Remove the upper and lower bushings (3, 5), washers (2, 6), and o-rings (4) from the valve body.
8. Remove the disc anti-friction rings (8) and o-rings (9, 19).
9. Remove the retaining ring (18) and o-rings (17) from the shaft.
10. The valve components can now be checked for problems and/or replaced.

## FK SERIES BUTTERFLY VALVES

### Valve Maintenance (cont'd)

#### Assembly

**Note:** Before assembling the valve components, it is advisable to lubricate the o-rings with a water soluble lubricant. **Be sure to consult the "IPEX Chemical Resistance Guide" and/or other trusted resources to determine specific lubricant-rubber compatibilities.**



#### Sizes 1-1/2" to 8":

1. Insert the primary liner (26) into the valve body (19). Ensure that the proper holes line up with those on the body.
2. Properly fit the o-rings (15) on the nylon bushing (16) (sizes 2-1/2" to 8") then insert the Teflon washer and bushing into the valve body from above.
3. Properly fit the disc o-rings (24, sizes 2-1/2" to 8") and anti-friction rings (23) on the disc (25), then insert into the valve liner taking care to center the holes.
4. Properly fit the o-rings (17, 18) and retaining ring (13, sizes 2-1/2" to 8") in their grooves on the shaft (14), then carefully insert into the valve body from above.
5. Fasten the shaft at the base of the valve body using the screw (21) and washer (22). Affix the cap (20) over the bolt.
6. For the lever handle style:
  - a. Place the pad (10) on the valve body then fasten using the screws (7), washers (11), nuts (12), and caps (28).
  - b. Affix the handle (2) using the screw (4), washer (5), and cap (3).
7. For the mounted gear box style:
  - a. Place the spacer pad (6) on the valve body then fasten using the screws (7), washers (11), nuts (12), and caps (28).
  - b. Carefully place the gear box on the stem, lining up the holes. Fasten using the necessary bolts and washers.

#### Sizes 10" to 12":

1. Insert the primary liner (7) into the valve body (1). Ensure that the proper holes line up with those on the body.
2. Properly fit the o-rings (4) on the upper and lower bushings (3, 5) then insert into the valve body from above and below along with the washers (2, 6).
3. Properly fit the disc o-rings (9, 19) and anti-friction rings (8) on the disc (10), then insert into the valve liner taking care to center the holes.
4. Properly fit the o-rings (17) and retaining ring (18) in their grooves on the shaft (16), then carefully insert into the valve body from above.
5. Fasten the shaft at the base of the valve body using the screw (14) and washers (11, 12, and 15). Affix the cap (13) over the bolt.
6. Carefully place the gear box on the stem, lining up the holes. Fasten using the necessary bolts and washers.

#### Operating Notes

The FK handle incorporates a locking mechanism that prevents unintentional rotation. When engaged, the spring-loaded handle release is locked and the valve cannot be cycled. A padlock can be installed through this portion of the handle as an additional safety precaution.



## FE SERIES BUTTERFLY VALVES

IPEX FE Series Butterfly Valves incorporate many features of our industrial FK valve, yet the all PVC construction and EPDM liner make this valve the perfect choice for water and light industrial applications. The special trapezoid shape of the liner and serrated body cavity guarantee a bubble tight seal while keeping break-away torque at an absolute minimum. This versatile valve features double self-lubricating seals, direct actuator mount capability, and the option of either a lever handle or mounted gear box. Inserting stainless steel lugs into special molded features in the body allows for end of line installation. FE Series Butterfly Valves are part of our complete Xirtec®140 systems of pipe, valves, and fittings, engineered and manufactured to our strict quality, performance, and dimensional standards.



ASTM D1784



ANSI B16.5

### Valve Availability

Body Material:	PVC
Disc Material:	PVC
Size Range:	1-1/2" through 12"
Pressure:	232psi (1-1/2" to 2") 150psi (2-1/2" to 8") 75psi (10" to 12")
Seats:	EPDM
Seals:	EPDM
Body Style:	Wafer
Control Style:	Lever Handle or Mounted Gear Box
End Connections:	Flanged (ANSI 150)



## FE SERIES BUTTERFLY VALVES

### Sample Specification

#### 1.0 Butterfly Valves - FE

##### 1.1 Material

- The valve body and disc shall be made of PVC compound which shall meet or exceed the requirements of cell classification 12454 according to ASTM D1784.
  - The valve shaft shall be made of zinc plated steel (sizes 1-1/2" to 8").
- or
- The valve shaft shall be made of 420 stainless steel (sizes 10" and 12").

##### 1.2 Seats

- The disc liner shall be made of EPDM.

##### 1.3 Seals

- The o-ring seals shall be made of EPDM.

- 1.4 All wetted parts of the valves shall comply with standards that are equivalent to NSF Standard 61 for potable water.

#### 2.0 Connections

##### 2.1 Flanged style

- The ANSI 150 flanged connections shall conform to the dimensional standard ANSI B16.5.

#### 3.0 Design Features

- The valve shall be of wafer design.
- Manual control of the valve shall be achieved through the use of either a lever handle or mounted gear box (specifier must select one).
- The shaft shall have standard ISO square dimensions for direct mounting of actuators.

- The disc seat shall be a trapezoidal elastomeric liner and provide a bubble tight seal.
- The liner shall completely isolate the valve body from the process flow.
- The liner shall function as a flange gasket on both sides of the valve.
- The body cavity shall feature special channeling to prevent liner slippage and compression.
- The disc, seats, and seals shall be the only wetted parts.
- Teflon® seated o-ring seals shall prevent the shaft from becoming wetted.

#### 3.1 Pressure Rating

- All valves sizes 1-1/2" through 2" shall be rated at 232psi at 73°F (23°C).
- All valves sizes 2-1/2" through 8" shall be rated at 150psi at 73°F (23°C).
- All valves sizes 10" through 12" shall be rated at 75psi at 73°F (23°C).

#### 3.2 Markings

- All valves shall be marked to indicate size, material designation, and manufacturers name or trade mark.

#### 3.3 Color Coding

- All valves shall be color-coded dark gray.

- 4.0 All valves shall be Xirtec®140 by IPEX or approved equal.

## FE SERIES BUTTERFLY VALVES

### Dimensions



Dimension (inches)										
Size	DN	Z	B2	B3	H	A <sub>min</sub>	A <sub>max</sub>	f	# holes	Pattern
1-1/2	1.57	1.30	2.36	4.17	5.20	3.68	4.29	0.75	4	square
2	1.97	1.69	2.76	4.45	5.79	4.25	4.88	0.75	4	square
2-1/2	2.56	1.81	3.15	4.84	6.50	5.04	5.67	0.75	4	square
3	3.15	1.93	3.54	5.59	5.12	5.71	6.26	0.75	4	rectangular
4	3.94	2.20	4.13	5.98	5.91	6.50	7.48	0.75	4	rectangular
5	4.92	2.52	4.76	6.93	7.28	8.03	8.46	0.91	4	rectangular
6	5.91	2.76	5.20	7.44	8.27	9.06	9.53	0.91	4	rectangular
8	7.87	2.80	6.34	8.46	12.80	11.02	11.73	0.91	8	square
10	9.84	4.49	8.27	9.76	15.94	14.25	14.25	1.00	12	square
12	11.81	4.49	9.65	12.01	18.70	17.00	17.00	1.00	12	square

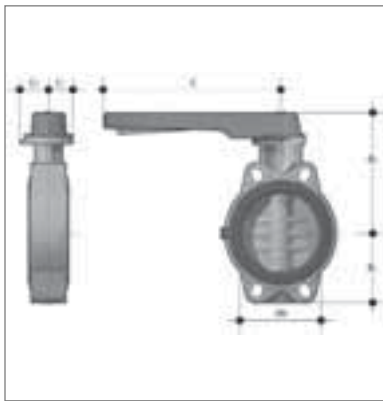

Lever Handle - Dimension (inches)								
Size	DN	C1	C2	C	B2	B3	# holes	Pattern
1-1/2	1.57	1.77	1.65	6.89	2.36	5.35	4	square
2	1.97	1.77	1.65	6.89	2.76	5.63	4	square
2-1/2	2.56	1.77	2.09	9.84	3.15	6.61	4	square
3	3.15	1.77	2.09	9.84	3.54	7.17	4	rectangular
4	3.94	1.77	2.09	9.84	4.13	7.72	4	rectangular
5	4.92	1.77	2.09	13.19	4.76	8.46	4	rectangular
6	5.91	1.77	2.09	13.19	5.20	9.02	4	rectangular
8	7.87	2.56	3.23	16.73	6.34	12.17	8	square

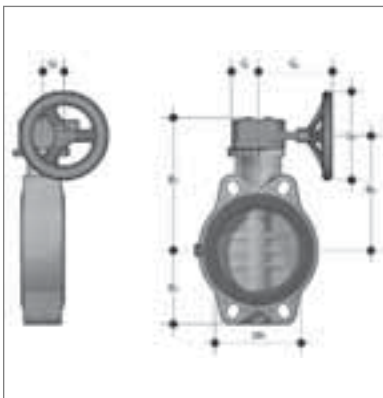

Mounted Gear Box - Dimension (inches)										
Size	DN	G2	G	G1	G3	B2	B5	B6	# holes	Pattern
2-1/2	2.56	1.54	1.89	5.31	4.92	3.15	6.81	5.71	4	square
3	3.15	1.54	1.89	5.31	4.92	3.54	7.36	6.26	4	rectangular
4	3.94	1.54	1.89	5.31	4.92	4.13	7.91	6.81	4	rectangular
5	4.92	1.54	1.89	5.67	7.87	4.76	8.66	7.56	4	rectangular
6	5.91	1.54	1.89	5.67	7.87	5.20	9.25	8.15	4	rectangular
8	7.87	2.36	2.56	6.89	7.87	6.34	11.34	10.12	8	square
10	9.84	2.99	3.46	9.29	9.84	8.27	12.48	11.06	12	square
12	11.81	2.99	3.46	9.29	9.84	9.65	14.72	13.31	12	square

## FE SERIES BUTTERFLY VALVES

### Dimensions (cont'd)

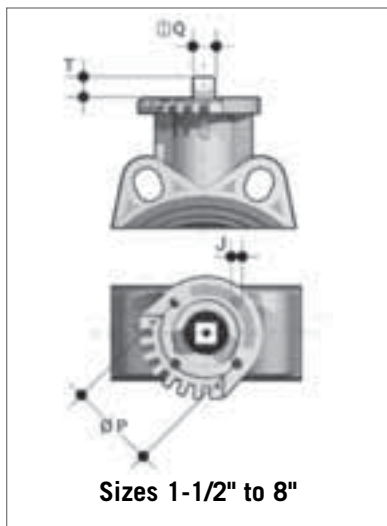

Mounting Pad for Actuation - Dimension (inches)					
Size	ISO	J	P	T	Q
1-1/2	F05	0.28	1.97	0.47	0.43
2	F05	0.28	1.97	0.47	0.43
2-1/2	F05 / F07	0.28 / 0.35	1.97 / 2.76	0.47	0.43
3	F07	0.35	2.76	0.63	0.55
4	F07	0.35	2.76	0.63	0.55
5	F07	0.35	2.76	0.75	0.67
6	F07	0.35	2.76	0.75	0.67
8	F10	0.43	4.02	0.94	0.87
10	F10 / F12 / F14	0.43 / 0.51 / 0.67	4.02 / 4.92 / 5.51	0.94	0.87
12	F10 / F12 / F14	0.43 / 0.51 / 0.67	4.02 / 4.92 / 5.51	0.94	0.87

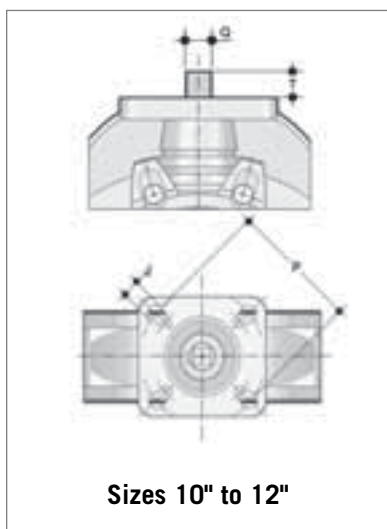

### Weights

Size	Approximate Weight (lbs)		
	Valve	w/ Handle	w/ Gear Box
1-1/2	1.27	1.82	-
2	1.66	2.23	-
2-1/2	2.20	3.13	5.25
3	3.09	3.62	5.73
4	3.86	4.39	6.50
5	5.62	6.68	9.70
6	7.28	8.22	11.24
8	13.23	18.17	20.41
10	26.46	-	41.01
12	41.89	-	56.44

## FE SERIES BUTTERFLY VALVES

### Pressure – Temperature Ratings

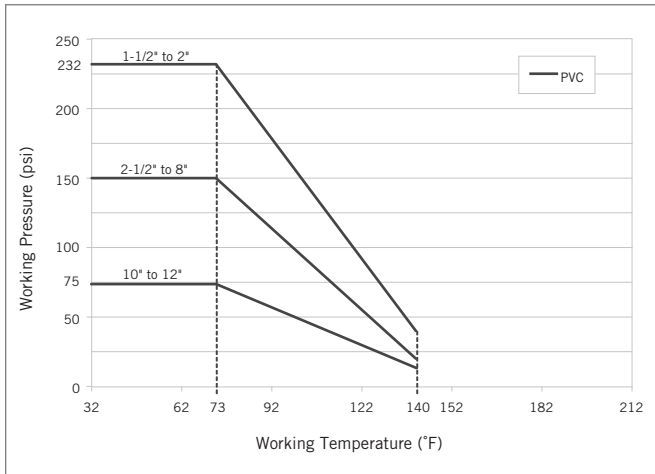

### Flow Coefficients

Size	Cv
1-1/2	70
2	90
2-1/2	119
3	249
4	413
5	690
6	1309
8	2135
10	3724
12	5712

### Pressure Loss Chart

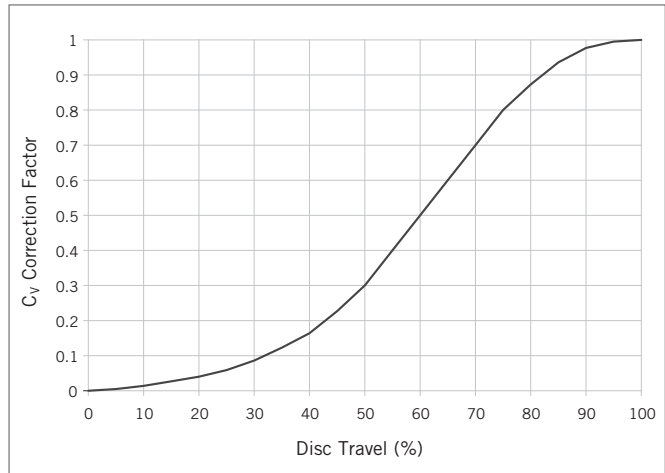
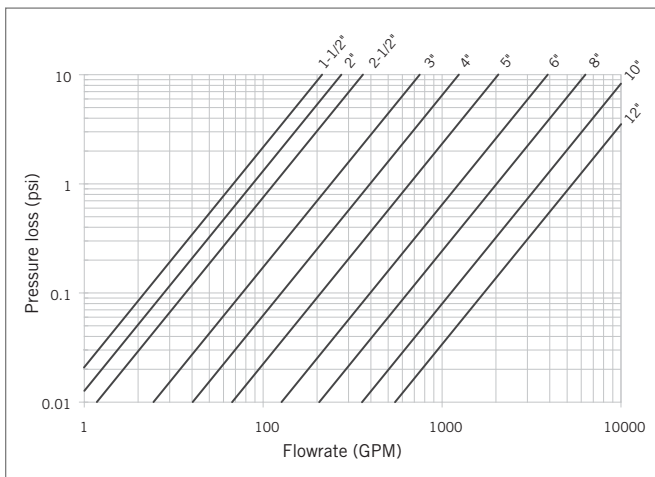

BUTTERFLY VALVES

## FE SERIES BUTTERFLY VALVES

### Components

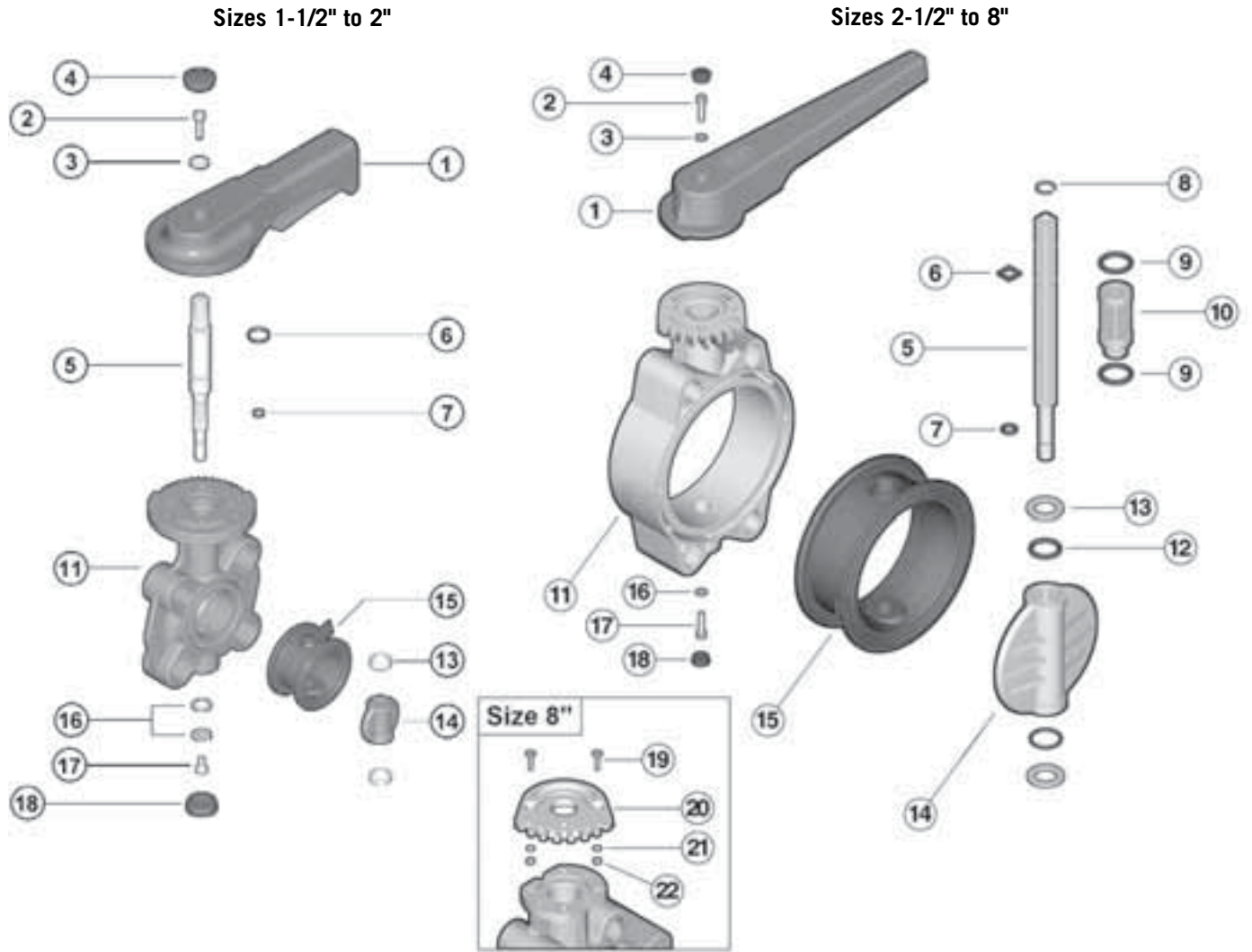

#	Component	Material	Qty
1*	handle	PVC	1
2	screw	SS	1
3	washer	SS	1
4	cap	PE	1
5*	shaft	zinc plated steel	1
6*	shaft o-ring	EPDM or Viton®	1
7*	shaft o-ring	EPDM or Viton®	1
8	retaining ring	SS	1
9*	bushing o-ring	EPDM or Viton®	2
10	bushing	Nylon	1
11	body	PVC	1

#	Component	Material	Qty
12*	disc o-ring	EPDM or Viton®	2
13*	anti-friction ring	PTFE	2
14*	disc	PVC	1
15*	primary liner	EPDM or Viton®	1
16	washer	SS	1
17	screw	SS	1
18	cap	PE	1
19	screw	SS	2
20	pad	PVC	1
21	washer	SS	2
22	nut	SS	2

\* Spare parts available.

## FE SERIES BUTTERFLY VALVES

### Components (cont'd)

Sizes 10" to 12"

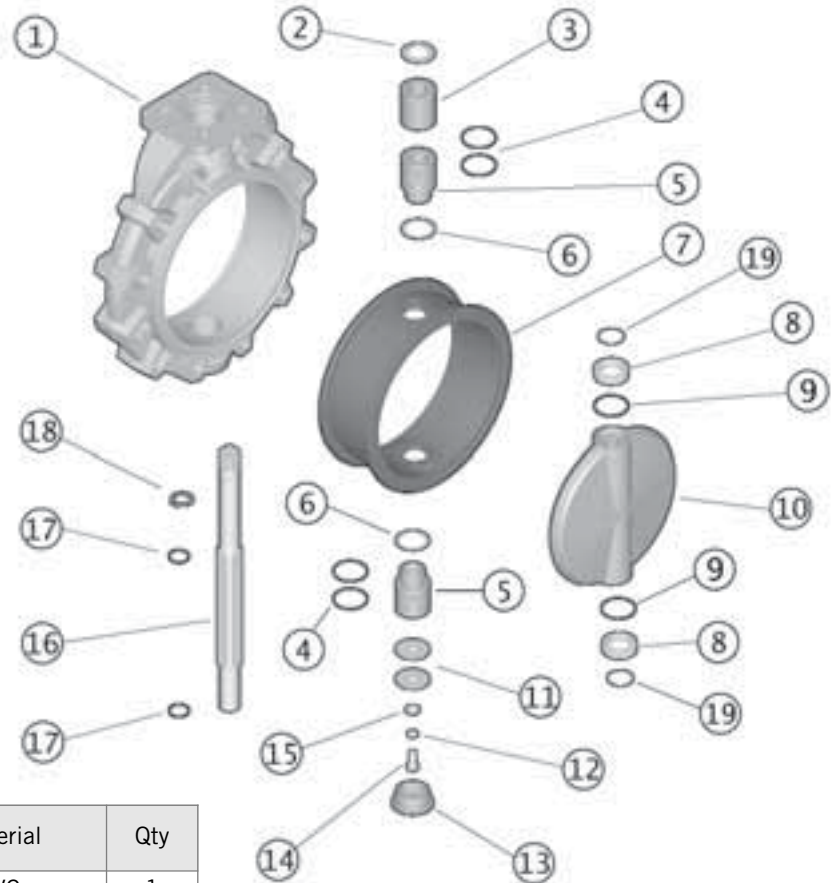

BUTTERFLY VALVES

#	Component	Material	Qty
1	body	PVC	1
2	washer	SS	1
3	bushing	PP	1
4*	bushing o-ring	EPDM	4
5	bushing for o-ring	PP	2
6	washer	PTFE	2
7*	primary liner	EPDM	1
8*	anti-friction ring	PTFE	2
9*	disc o-ring	EPDM	2
10*	disc	PVC	1
11	washer	SS	2
12	washer	SS	1
13	cap	PE	1
14	screw	SS	1
15	washer	SS	1
16*	shaft	420 SS	1
17*	shaft o-ring	EPDM	2
18	retaining ring	SS	1
19	o-ring	EPDM	2

\* Spare parts available.

## FE SERIES BUTTERFLY VALVES

### Installation Procedures

1. For the lever handle style, attach the handle (part #1 on previous pages) to the valve body (11) using the supplied bolt (2) and washer (3). Affix the cap (4) over the bolt.
2. Ensure that the length of the bolts is sufficient for the size of valve being installed. Due to the varying designs of plastic flanges, there is no recommended minimum length. However, a length that results in at least 5 exposed threads on each side should be sufficient.
3. Please refer to the appropriate application sub-section:
  - a. For typical inline installation, ensure that the disc is in the partially closed position then carefully insert the valve into the piping system between the two flanges. Insert the bolts, washers, and nuts (if necessary), then hand tighten. Take care to properly line up the valve and flanges as any misalignment may cause leakage.
  - b. For lugged version end of line installation, insert the necessary steel lugs into the valve body. Ensure that the disc is in the partially closed position then carefully position the valve on the flange. Insert the bolts, and washers, then hand tighten. Take care to properly line up the valve and flange as any misalignment may cause leakage.
4. To avoid damage to the primary gasket, cycle the valve to the open position before tightening the bolts. For correct joining procedure, please refer to the section entitled, "Joining Methods – Flanging" in the IPEX Industrial Technical Manual Series, "Volume I: Vinyl Process Piping Systems". The bolts should be tightened in an even pattern to the nominal torque in the table below. These torque ratings are sufficient to maintain a watertight seal at the maximum rated operating pressure.

**Note:** End of line installation will cause the maximum rated pressure to be reduced to the values listed in the table below. If the process media is dirty or contains suspended particles, it is advisable to install the valve in an orientation in which the shaft is not vertical (see diagrams). Over time, particles may collect at the bottom of the valve posing a threat to the seal between the disc, liner, and shaft.

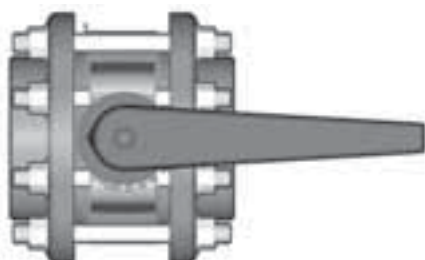
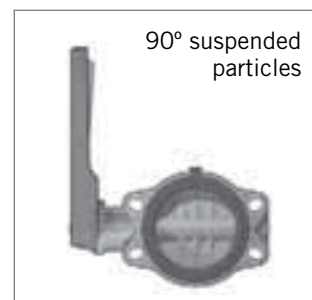
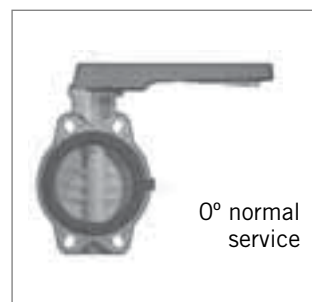
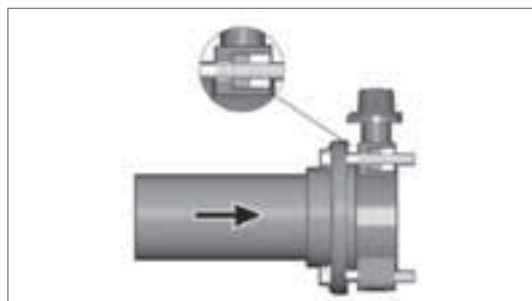

Size	Nominal Bolt Torque (ft-lbs)	Lugged P <sub>max</sub> (psi)
1-1/2	7	90
2	9	90
2-1/2	11	90
3	13	90
4	15	90
5	26	90
6	30	60
8	41	60
10	52	-
12	52	-

## FE SERIES BUTTERFLY VALVES

### Valve Maintenance

#### Disassembly

1. If removing the valve from an operating system, isolate the valve from the rest of the system. Be sure to depressurize and drain the isolated branch before continuing.
2. Cycle the valve to a partially open position then loosen each bolt holding the valve to the pipe flange(s). Please refer to the section entitled, "Joining Methods – Flanging" in the IPEX Industrial Technical Manual Series, "Volume I: Vinyl Process Piping Systems" for a recommended bolt tightening pattern diagram. Follow the same pattern when disassembling the flanged joint(s) then carefully remove the valve from the line.



#### Sizes 1-1/2" to 8":

3. For the lever handle style, remove the cap (4) then loosen the screw (2) and washer (3) to remove the handle (1).
4. For the mounted gear box style, loosen and remove the bolts and washers fixed to the gear box. Carefully remove the gear box from the valve taking care not to damage the stem.
5. For 8" sizes, loosen and remove the bolts (19), washers (21), and nuts (22) then remove the spacer pad (20) from the valve body.
6. Remove the cap (18) then loosen and remove the screw (17) and washer(s) (16) from the base of the valve body.
7. Carefully pull the shaft (5) out of the valve body then remove the disc (14).
8. Remove the primary liner (15) from the valve body.
9. Remove the nylon bushing (10) and o-rings (9) from the valve body (sizes 2-1/2" to 8").
10. Remove the disc anti-friction rings (13), and o-rings (12, sizes 2-1/2" to 8").
11. Remove the retaining ring (8, sizes 2-1/2" to 8") and o-rings (6, 7) from the shaft.
12. The valve components can now be checked for problems and/or replaced.

#### Sizes 10" to 12":

3. Loosen and remove the bolts and washers fixed to the gear box. Carefully remove the gear box from the valve taking care not to damage the stem.
4. Remove the cap (13) then loosen and remove the screw (14) and washers (11, 12, and 15) from the base of the valve body (1).
5. Carefully pull the shaft (16) out of the valve body then remove the disc (10).
6. Remove the primary liner (7) from the valve body
7. Remove the upper and lower bushings (3, 5), washers (2, 6), and o-rings (4) from the valve body.
8. Remove the disc anti-friction rings (8) and o-rings (4, 9).
9. Remove the retaining ring (18) and o-rings (17) from the shaft.
10. The valve components can now be checked for problems and/or replaced.

## FE SERIES BUTTERFLY VALVES

### Valve Maintenance (cont'd)

#### Assembly

**Note:** Before assembling the valve components, it is advisable to lubricate the o-rings with a water soluble lubricant. **Be sure to consult the “IPEX Chemical Resistance Guide” and/or other trusted resources to determine specific lubricant-rubber compatibilities.**



#### Sizes 1-1/2" to 8":

1. Insert the primary liner (15) into the valve body (11). Ensure that the proper holes line up with those on the body.
2. Properly fit the o-rings (9) on the nylon bushing (10) (sizes 2-1/2" to 8") then insert into the valve body from above.
3. Properly fit the disc o-rings (12, sizes 2-1/2" to 8") and anti-friction rings (13) on the disc (14), then insert into the valve liner taking care to center the holes.
4. Properly fit the o-rings (6, 7) and retaining ring (8, sizes 2-1/2" to 8") in their grooves on the shaft (6), then carefully insert into the valve body from above.
5. Fasten the shaft at the base of the valve body using the screw (17) and washer (16). Affix the cap (18) over the bolt.
6. For 8" sizes, affix the spacer pad (20) to the valve body using the screws (19), washers (21), and nuts (22).
7. For the lever handle style, affix the handle (1) using the screw (2), washer (3), and cap (4).
8. For the mounted gear box style, carefully place the gear box on the stem, lining up the holes. Fasten using the necessary bolts and washers.

#### Sizes 10" to 12":

1. Insert the primary liner (7) into the valve body (1). Ensure that the proper holes line up with those on the body.
2. Properly fit the o-rings (4) on the upper and lower bushings (3, 5) then insert into the valve body from above and below along with the washers (2, 6).
3. Properly fit the disc o-rings (4, 9) and anti-friction rings (8) on the disc (10), then insert into the valve liner taking care to center the holes.
4. Properly fit the o-rings (17) and retaining ring (18) in their grooves on the shaft (16), then carefully insert into the valve body from above.
5. Fasten the shaft at the base of the valve body using the screw (14) and washers (11, 12, and 15). Affix the cap (13) over the bolt.
6. Carefully place the gear box on the stem, lining up the holes. Fasten using the necessary bolts and washers.

## SECTION FOUR: DIAPHRAGM VALVES

### VM SERIES MANUAL DIAPHRAGM VALVES

IPEX VM Series Diaphragm Valves are the ideal solution for modulating flow and controlling dirty or contaminated fluids in a variety of applications. The weir-style design allows for precise throttling while the compact design allows for installation in any orientation. The modular nature of this valve results in many material, body style, and diaphragm options. VM Series Diaphragm Valves are part of our complete Xirtec®140, Corzan® and SFPP systems of pipe, valves, and fittings, engineered and manufactured to our strict quality, performance, and dimensional standards.

#### Valve Availability

Body Material:	PVC, CPVC, PP, PVDF
Size Range:	1/2" through 4"
Pressure:	150psi
Diaphragm:	EPDM, Viton® (FPM) or PTFE (EPDM backed)
Control Style:	Manual Handwheel
End Connections:	Spigot True Union (Socket) Flanged (ANSI 150)



ASTM D1784  
ASTM D1785  
ASTM D2466  
ASTM D2467  
ASTM D3222  
ASTM D4101  
ASTM F439  
ASTM F441



ANSI B16.5



ISO 10931  
ISO 11922-1



## VM SERIES MANUAL DIAPHRAGM VALVES

**Sample Specification****1.0 Diaphragm Valves - VM****1.1 Material**

- The valve body, including end connectors and unions, shall be made of PVC compound which shall meet or exceed the requirements of cell classification 12454 according to ASTM D1784.
- or The valve body, including end connectors and unions shall be made of Corzan® CPVC compound which shall meet or exceed the requirements of cell classification 23447 according to ASTM D1784.
- or The valve body, including end connectors and unions shall be made of stabilized PP homopolymer compound, also containing a RAL 7032 pigment, which shall meet or exceed the requirements of Type I Polypropylene according to ASTM D4101.
- or The valve body, including end connectors and unions shall be made of virgin, non-regrind PVDF compound which shall meet or exceed the requirements of Table 1 according to ASTM D3222.
- The valve bonnet assembly shall be made of high temperature, high strength, glass-filled polypropylene.

**1.2 Diaphragm**

- The diaphragm shall be made of EPDM.
- or The diaphragm shall be made of Viton® (FPM).
- or The diaphragm shall be made of PTFE (backed with EPDM).

**1.3** All wetted parts of the valves shall comply with standards that are equivalent to NSF Standard 61 for potable water.

**2.0 Connections****2.1 Spigot style**

- The IPS spigot PVC end connectors shall conform to the dimensional standard ASTM D1785.
- or The IPS spigot CPVC end connectors shall conform to the dimensional standard ASTM F441.
- or The Metric spigot PP end connectors shall conform to the dimensional standard ISO 11922-1.
- or The Metric spigot PVDF end connectors shall conform to the dimensional standard ISO 10931.

**2.2 Socket style**

- The IPS socket PVC end connectors shall conform to the dimensional standards ASTM D2466 and ASTM D2467.
- or The IPS socket CPVC end connectors shall conform to the dimensional standard ASTM F439.

- or The Metric socket PP end connectors shall conform to the dimensional standard ISO 11922-1.
- or The Metric socket PVDF end connectors shall conform to the dimensional standard ISO 10931.

**2.3 Flanged style**

- The ANSI 150 flanged PVC end connectors shall conform to the dimensional standard ANSI B16.5.
- or The ANSI 150 flanged CPVC end connectors shall conform to the dimensional standard ANSI B16.5.
- or The ANSI 150 flanged PP end connectors shall conform to the dimensional standard ANSI B16.5.
- or The ANSI 150 flanged PVDF end connectors shall conform to the dimensional standard ANSI B16.5.

**3.0 Design Features**

- All valves shall be weir-style for throttling applications.
- All bodies to be used with EPDM or Viton® diaphragms shall feature raised molded sealing rings (concentric).
- All bodies to be used with PTFE diaphragms shall be machined flat.
- All PTFE diaphragms shall feature a raised molded ring to combine sealing performance and longer life.
- All through bolts shall be made of 304 stainless steel.
- All manual valves shall have a rising position indicator.
- Bodies of all sizes and materials shall have mounting brass inserts.

**3.1 Pressure Rating**

- All valves shall be rated at 150psi at 73°F (23°C).

**3.2 Markings**

- All valves shall be marked to indicate size, material designation, and manufacturers name or trade mark.

**3.4 Color Coding**

- All PVC valves shall be color-coded dark gray.
- or All CPVC valves shall be color-coded light gray.
- or All PP valves shall be color-coded beige gray.
- or All PVDF valves shall not be color-coded and be white in appearance.
- All bonnet assemblies shall be color-coded red.

**4.0** All valves shall be Xirtec® 140, Corzan®, PP or PVDF by IPEX or approved equal.

## VM SERIES MANUAL DIAPHRAGM VALVES

### Dimensions

#### Spigot Connections

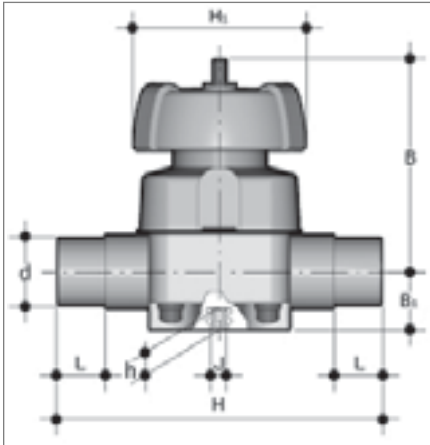

Size	Dimension (inches)			
	PVC / CPVC d (in)	PP / PVDF d (mm)	H	L
1/2	0.84	20	4.88	0.63
3/4	1.05	25	5.67	0.75
1	1.32	32	6.06	0.87
1-1/4	1.66	40	6.85	1.02
1-1/2	1.90	50	7.64	1.22
2	2.38	63	8.82	1.50
2-1/2	2.88	75	11.18	1.73
3	3.50	90	11.81	2.01
4	4.50	110	13.39	2.40

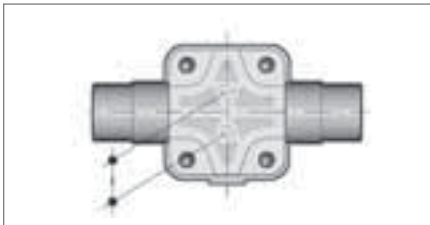

Size	Dimension (inches)					
	B1	B	H1	J	h	I
1/2	1.02	3.74	3.54	M6	0.47	0.98
3/4	1.02	3.74	3.54	M6	0.47	0.98
1	1.02	3.74	3.54	M6	0.47	0.98
1-1/4	1.57	4.96	4.53	M8	0.71	1.75
1-1/2	1.57	4.96	4.53	M8	0.71	1.75
2	1.57	5.83	5.51	M8	0.71	1.75
2-1/2	2.17	8.86	8.46	M12	0.91	3.94
3	2.17	8.86	8.46	M12	0.91	3.94
4	2.72	11.61	9.84	M12	0.91	4.72

#### True Union Connections

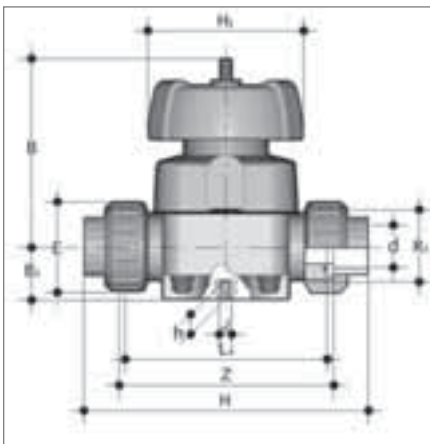

Size	Dimension (inches)							
	PVC / CPVC			PP / PVDF			LA	B1
	d (in)	H	Z	d (mm)	H	Z		
1/2	0.84	6.30	4.53	20	5.79	4.53	4.25	1.02
3/4	1.05	6.57	4.53	25	6.06	4.57	4.25	1.02
1	1.32	7.09	4.80	32	6.61	4.88	4.57	1.02
1-1/4	1.66	8.19	5.67	40	7.56	5.51	5.28	1.57
1-1/2	1.90	9.21	6.46	50	8.74	6.30	6.06	1.57
2	2.38	10.71	7.68	63	10.47	7.48	7.24	1.57

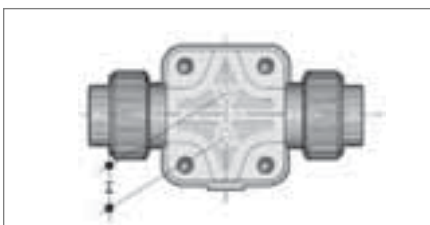

Size	Dimension (inches)						
	B	H1	E	R1	J	h	I
1/2	3.74	3.54	1.61	1	M6	0.47	0.98
3/4	3.74	3.54	1.97	1-1/4	M6	0.47	0.98
1	3.74	3.54	2.28	1-1/2	M6	0.47	0.98
1-1/4	4.96	4.53	2.83	2	M8	0.63	1.75
1-1/2	4.96	4.53	3.11	2-1/4	M8	0.63	1.75
2	5.83	5.51	3.86	2-3/4	M8	0.63	1.75

## VM SERIES MANUAL DIAPHRAGM VALVES

### ANSI 150 Flanged (Vanstone) Connections

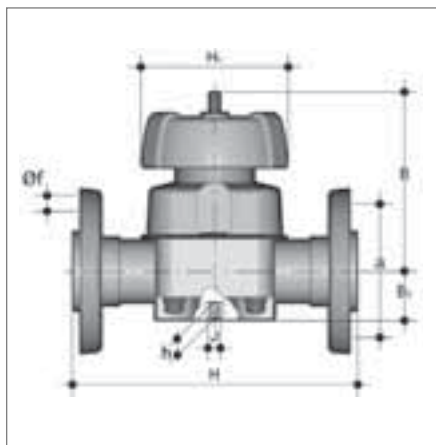

Size	Dimension (inches)				
	d	H	B1	B	H1
1/2	0.84	5.37	1.02	3.74	3.54
3/4	1.05	6.11	1.02	3.74	3.54
1	1.32	6.58	1.02	3.74	3.54
1-1/4	1.66	7.30	1.57	4.96	4.53
1-1/2	1.90	8.02	1.57	4.96	4.53
2	2.38	8.88	1.57	5.83	5.51
2-1/2	2.88	11.34	2.17	8.86	8.46
3	3.50	11.81	2.17	8.86	8.46
4	4.50	13.39	2.72	11.61	9.84

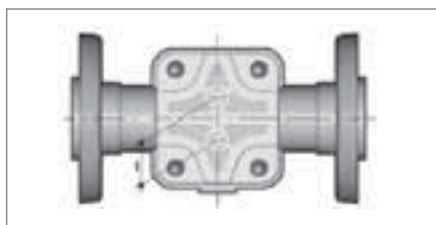

Size	# holes	Dimension (inches)				
		f	F	J	h	l
1/2	4	5/8	2-3/8	M6	0.47	0.98
3/4	4	5/8	2-3/4	M6	0.47	0.98
1	4	5/8	3-1/8	M6	0.47	0.98
1-1/4	4	5/8	3-1/2	M8	0.71	1.75
1-1/2	4	5/8	3-7/8	M8	0.71	1.75
2	4	3/4	4-3/4	M8	0.71	1.75
2-1/2	4	3/4	5-1/2	M12	0.91	3.94
3	4	3/4	6	M12	0.91	3.94
4	4	3/4	7-1/2	M12	0.91	4.72

### Diaphragm

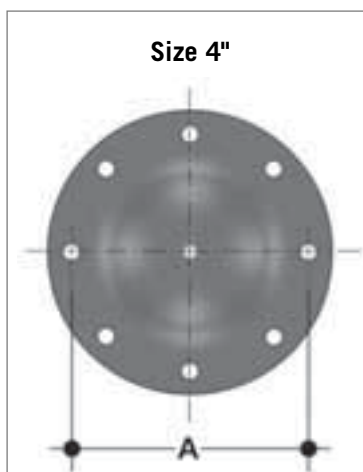
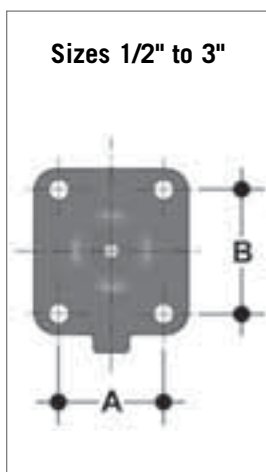

Size (inches)	Size (mm)	Dimension (inches)	
		A	B
1/2	20	1.81	2.13
3/4	25	1.81	2.13
1	32	1.81	2.13
1-1/4	40	2.56	2.76
1-1/2	50	2.56	2.76
2	63	3.07	3.23
2-1/2	75	4.49	5.00
3	90	4.49	5.00
4	110	7.60	-

## VM SERIES MANUAL DIAPHRAGM VALVES

### Weights

Size (inches)	Approximate Weight (lbs)									
	PVC			CPVC			PP		PVDF	
	Spigot	True Union	Flanged	Spigot	True Union	Flanged	Spigot	True Union	Spigot	True Union
1/2	1.54	1.83	1.92	1.59	1.90	1.99	1.32	1.57	1.70	2.32
3/4	1.54	1.90	2.06	1.59	1.97	2.13	1.32	1.65	1.70	2.48
1	1.54	1.97	2.26	1.59	2.05	2.34	1.32	1.72	1.70	2.61
1-1/4	3.31	3.64	4.23	3.44	3.79	4.41	2.65	3.13	3.77	4.60
1-1/2	3.31	3.81	4.53	3.44	3.97	4.72	2.65	3.22	3.77	4.79
2	5.29	6.17	7.31	5.51	6.43	7.63	4.19	5.25	5.89	7.60
2-1/2	15.43	n/a	18.23	16.01	n/a	18.95	13.23	n/a	17.28	n/a
3	15.43	n/a	18.60	16.01	n/a	19.33	13.23	n/a	17.15	n/a
4	23.15	n/a	28.34	23.94	n/a	29.39	19.84	n/a	25.65	n/a

### Pressure – Temperature Ratings

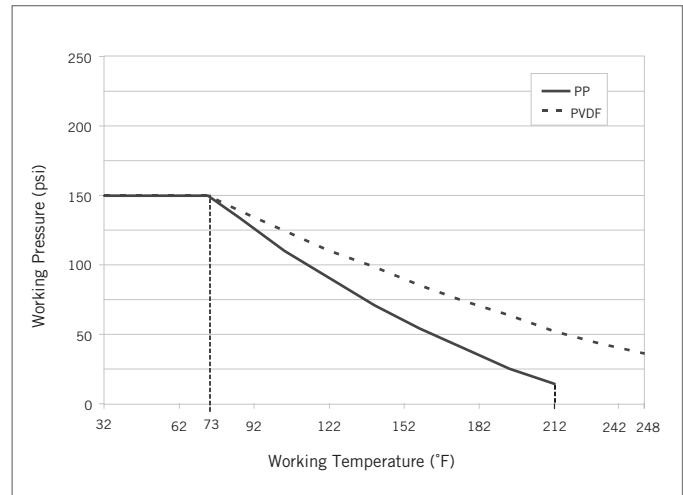
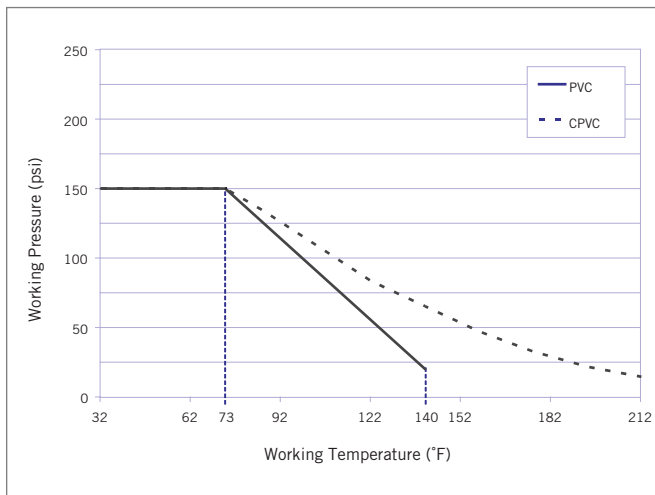

DIAPHRAGM VALVES

### Flow Coefficients

Size (in)	C <sub>v</sub>
1/2	6.51
3/4	9.52
1	12.3
1-1/4	21.0
1-1/2	29.1
2	53.6
2-1/2	91.0
3	140
4	189

### Pressure Loss Chart

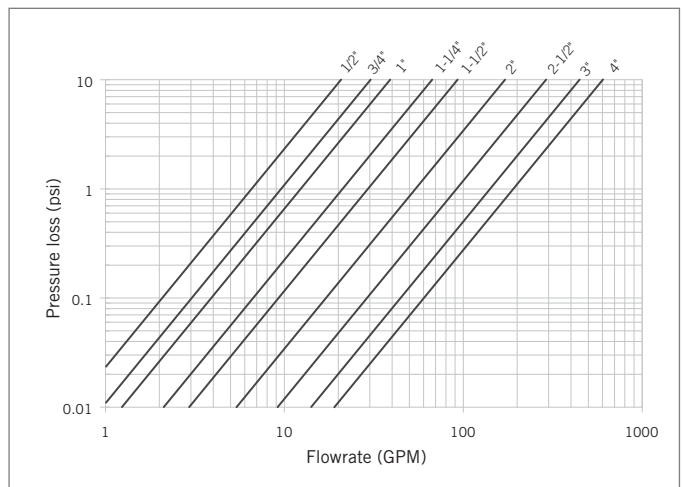

## VM SERIES MANUAL DIAPHRAGM VALVES

### Components

Sizes 1/2" to 2"

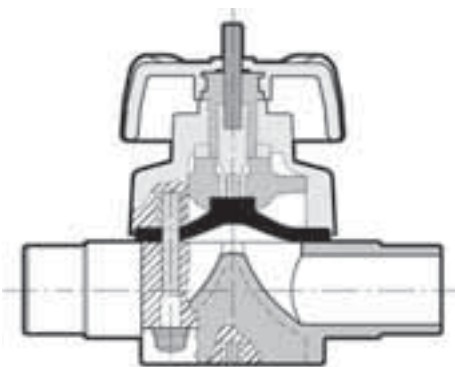
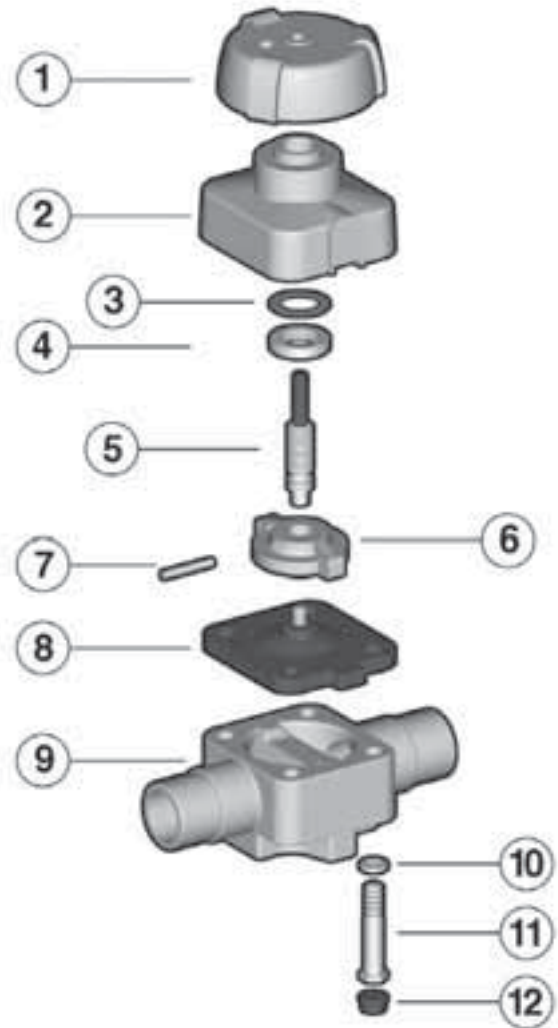

#	Component	Material	Qty
1*	handwheel	GFPP	1
2*	bonnet	GFPP	1
3*	compression bearing	POM	1
4*	security ring	brass	1
5*	indicator - stem	SS	1
6*	compressor	PBT	1
7*	pin	SS	1
8*	diaphragm	EPDM / Vitor® / PTFE	1
9*	valve body	PVC / CPVC / PP / PVDF	1
10*	washer	zinc plated steel	4
11*	hex bolt	zinc plated steel	4
12*	protective cap	PE	4

\* Spare parts available. Items 1 through 7 are supplied as an assembly.  
 Contact IPEX for availability of spare components for True Union and Flanged style valves.  
**Note: Sizes 2-1/2" to 4" have similar components.**

## VM SERIES MANUAL DIAPHRAGM VALVES

### Installation Procedures

1. The valve may be installed in any position or direction.
2. Please refer to the appropriate connection style sub-section:
  - a. For spigot style, solvent cement each pipe onto the ends of the valve body (part #9 on previous page). Ensure that excess solvent does not run into the body of the valve.
  - b. For true union style, remove the union nuts and slide them onto the pipe.
    - i. For socket style, solvent cement the end connectors onto the pipe ends. For correct joining procedure, please refer to the section entitled, *“Joining Methods - Solvent Cementing”* in the IPEX Industrial Technical Manual Series, *“Volume I: Vinyl Process Piping Systems”*. Ensure that excess solvent does not run into the body of the valve. **Be sure to allow sufficient cure time before continuing with the valve installation.**
    - ii. For threaded style, thread the end connectors onto the pipe ends. For correct joining procedure, please refer to the section entitled, *“Joining Methods - Threading”* in the IPEX Industrial Technical Manual Series, *“Volume I: Vinyl Process Piping Systems”*.
    - iii. Ensure that the socket o-rings are properly fitted in their grooves then carefully place the valve in the system between the two end connections.
    - iv. Tighten both union nuts. Hand tightening is typically sufficient to maintain a seal for the maximum working pressure. Over-tightening may damage the threads on the valve body and/or the union nut, and may even cause the union nut to crack.
  - c. For flanged style, join both flanges to the pipe flanges. For correct joining procedure, please refer to the section entitled, *“Joining Methods - Flanging”* in the IPEX Industrial Technical Manual Series, *“Volume I: Vinyl Process Piping Systems”*.
3. If anchoring is required, fix the valve to the supporting structure using the mounting holes on the bottom of the valve body.

## VM SERIES MANUAL DIAPHRAGM VALVES

### Valve Maintenance

#### Disassembly

1. If removing the valve from an operating system, isolate the valve from the rest of the line. **Be sure to depressurize and drain the valve and isolated branch.**
2. If necessary, detach the valve from the support structure by disassembling the threaded connections on the bottom of the valve body (9).
3. Please refer to the appropriate connection style sub-section:
  - a. For spigot style, cut the pipe on either side of the valve and remove from the line.
  - b. For true union connections, loosen both union nuts and drop the valve out of the line. If retaining the socket o-rings, take care that they are not lost when removing the valve from the line.
  - c. For flanged style, loosen each bolt holding the valve to the pipe flanges. Please refer to the section entitled, *“Joining Methods - Flanging”* in the IPEX Industrial Technical Manual Series, **“Volume I: Vinyl Process Piping Systems”** for a recommended bolt tightening pattern diagram. Follow the same pattern when disassembling the flanged joints then carefully remove the valve from the line.
4. Remove the protective caps (12), then loosen and remove the bolts (11) and washers (10) from the bottom of the valve body.
5. Loosen and remove the diaphragm (8) from the compressor (6).
6. Rotate the handwheel (1) clockwise until the stem-compressor assembly (5, 6, 7) is released.
7. The valve components can now be checked for problems and/or replaced.

**Note:** It is not recommended to attempt to further disassemble the handwheel/bonnet assembly as it may cause irreversible damage to the components.

Size (inches)	Tightening Torque (in-lbs)	
	EPDM / FPM	PTFE
1/2	70 - 90	90 - 105
3/4	70 - 90	90 - 105
1	70 - 90	90 - 105
1-1/4	105 - 125	125 - 140
1-1/2	105 - 125	125 - 140
2	140 - 160	205 - 230
2-1/2	350 - 400	400 - 440
3	350 - 400	400 - 440
4	310 - 350	325 - 370

#### Assembly

**Note:** Before assembling the valve components, it is advisable to lubricate the o-rings with a water soluble lubricant. **Be sure to consult the “IPEX Chemical Resistance Guide” and/or other trusted resources to determine specific lubricant-rubber compatibilities.**

1. Insert the stem-compressor assembly (5, 6, 7) into the bonnet (2) and tighten by threading in a counterclockwise (left-hand thread) direction. The guide tabs on the compressor must be lined up with the bonnet grooves before cycling the handwheel (1) to further retract the compressor.
2. Insert the diaphragm (8) into the compressor (6) and turn in a clockwise direction until sufficiently tight. Ensure that the tab lines up with the notched side of the bonnet then cycle the handwheel counterclockwise until the diaphragm is fully retracted.
3. Place the bonnet and diaphragm onto the valve body (9) taking care to properly line up the sealing surfaces.
4. Insert the bolts (11) and washers (10) and tighten in an even (cross-like) pattern (see bolt torque chart).
5. Replace the protective caps (12) on the bolt heads.



## VM SERIES PNEUMATIC DIAPHRAGM VALVES

IPEX VM Series Diaphragm Valves are the ideal solution for modulating flow and controlling dirty or contaminated fluids in a variety of applications. The weir-style design allows for precise throttling while the compact design allows for installation in any orientation. This pneumatically actuated version provides automatic control with an extensive range of options and accessories. The modular nature of this valve results in many material, body style, and diaphragm options. VM Series Diaphragm Valves are part of our complete Xirtec®140, Corzan® and SFPP systems of pipe, valves, and fittings, engineered and manufactured to our strict quality, performance, and dimensional standards.

### Valve Availability

Body Material:	PVC, CPVC, PP, PVDF
Size Range:	1/2" through 4"
Pressure:	150psi (1/2" to 2") 90psi (2-1/2" to 4")
Diaphragm:	EPDM, Viton® (FPM) or PTFE (EPDM backed)
Control Style:	Pneumatically Actuated
End Connections:	Spigot True Union (Socket) Flanged (ANSI 150)



ASTM D1784  
ASTM D1785  
ASTM D2466  
ASTM D2467  
ASTM D3222  
ASTM D4101  
ASTM F439  
ASTM F441



ANSI B16.5



ISO 10931  
ISO 11922-1



## VM SERIES PNEUMATIC DIAPHRAGM VALVES

### Sample Specification

#### 1.0 Diaphragm Valves - VM

##### 1.1 Material

- The valve body, including end connectors and unions, shall be made of PVC compound which shall meet or exceed the requirements of cell classification 12454 according to ASTM D1784.
- or The valve body, including end connectors and unions shall be made of Corzan® CPVC compound which shall meet or exceed the requirements of cell classification 23447 according to ASTM D1784.
- or The valve body, including end connectors and unions, shall be made of stabilized PP homopolymer compound, also containing a RAL 7032 pigment, which shall meet or exceed the requirements of Type I Polypropylene according to ASTM D4101.
- or The valve body, including end connectors and unions shall be made of virgin, non-regrind PVDF compound which shall meet or exceed the requirements of Table 1 according to ASTM D3222.
- The valve bonnet assembly shall be made of high temperature, high strength, glass-filled polypropylene.

##### 1.2 Diaphragm

- The diaphragm shall be made of EPDM.
- or The diaphragm shall be made of Viton® (FPM).
- or The diaphragm shall be made of PTFE (backed with EPDM).

- 1.3** All wetted parts of the valves shall comply with standards that are equivalent to NSF Standard 61 for potable water.

#### 2.0 Connections

##### 2.1 Spigot style

- The IPS spigot PVC end connectors shall conform to the dimensional standard ASTM D1785.
- or The IPS spigot CPVC end connectors shall conform to the dimensional standard ASTM F441.
- or The Metric spigot PP end connectors shall conform to the dimensional standard ISO 11922-1.
- or The Metric spigot PVDF end connectors shall conform to the dimensional standard ISO 10931.

##### 2.2 Socket style

- The IPS socket PVC end connectors shall conform to the dimensional standards ASTM D2466 and ASTM D2467.
- or The IPS socket CPVC end connectors shall conform to the dimensional standard ASTM F439.
- or The Metric socket PP end connectors shall conform to the dimensional standard ISO 11922-1.
- or The Metric socket PVDF end connectors shall conform to the dimensional standard ISO 10931.

##### 2.3 Flanged style

- The ANSI 150 flanged PVC end connectors shall conform to the dimensional standard ANSI B16.5.
- or The ANSI 150 flanged CPVC end connectors shall

- conform to the dimensional standard ANSI B16.5.
- or The ANSI 150 flanged PP end connectors shall conform to the dimensional standard ANSI B16.5.
- or The ANSI 150 flanged PVDF end connectors shall conform to the dimensional standard ANSI B16.5.

#### 3.0 Design Features

- All valves shall be weir-style for throttling applications.
- All bodies to be used with EPDM or Viton® diaphragms shall feature raised molded sealing rings (concentric).
- All bodies to be used with PTFE diaphragms shall be machined flat.
- All PTFE diaphragms shall feature a raised molded ring to combine sealing performance and longer life.
- All through bolts shall be made of 304 stainless steel.
- Bodies of all sizes and materials shall have mounting brass inserts.

#### 3.1 Actuators

- All actuators shall be made of glass-filled polypropylene
- All actuators shall feature a smooth top (no nut holes) for cleanliness.
- The edge of the actuator membrane shall be inside of the actuator protective housing.
- All springs shall be cut from spring grade steel for maximum memory life and epoxy coated for maximum chemical resistance.
- Fail safe to open and double-acting actuators shall feature weak springs located in the center of the actuator.
- Fail safe to close actuators shall feature three concentric springs located in the middle of the actuator.
- The following accessories shall be available for all actuators: position indicator, stroke limiter, stroke limiter with position indicator, limit switch, limit switch box, 3-15psi positioner, 4-20 mA positioner, solenoid pilot valve.

#### 3.2 Pressure Rating

- Valve sizes 1/2" through 2" shall be rated at 150psi at 73°F (23°C).
- Valve sizes 2-1/2" through 4" shall be rated at 90psi at 73°F (23°C).

#### 3.3 Markings

- All valves shall be marked to indicate size, material designation, and manufacturers name or trade mark.

#### 3.4 Color Coding

- All PVC valves shall be color-coded dark gray.
- or All CPVC valves shall be color-coded light gray.
- or All PP valves shall be color-coded beige gray.
- or All PVDF valves shall not be color-coded and be white in appearance.
- All bonnet assemblies shall be color-coded red.

- 4.0** All valves shall be Xirtec® 140, Corzan®, PP or PVDF by IPEX or approved equal.

## VM SERIES PNEUMATIC DIAPHRAGM VALVES

### Dimensions

#### Normally Open & Air to Air – Spigot Connections

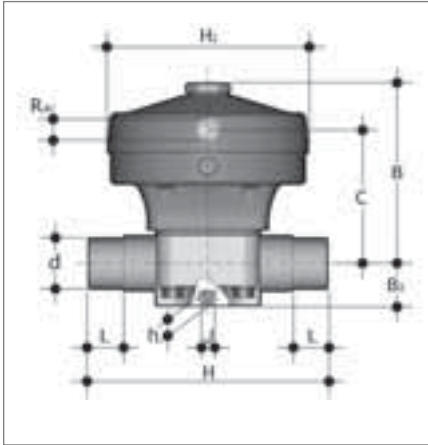

Size	Dimension (inches)				
	PVC / CPVC d (in)	PP / PVDF d (mm)	H	L	B1
1/2	0.84	20	4.88	0.63	1.02
3/4	1.05	25	5.67	0.75	1.02
1	1.32	32	6.06	0.87	1.02
1-1/4	1.66	40	6.85	1.02	1.57
1-1/2	1.90	50	7.64	1.22	1.57
2	2.38	63	8.82	1.50	1.57
2-1/2	2.88	75	11.18	1.73	2.17
3	3.50	90	11.81	2.01	2.17
4	4.50	110	13.39	2.40	2.72

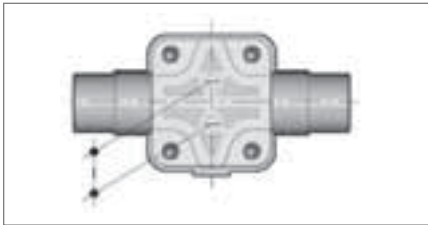

Size	Dimension (inches)						
	C	Ra	B	H1	J	h	l
1/2	4.72	1/4	5.67	4.96	M6	0.47	0.98
3/4	4.75	1/4	5.67	4.96	M6	0.47	0.98
1	4.72	1/4	5.67	4.96	M6	0.47	0.98
1-1/4	5.24	1/4	7.91	6.10	M8	0.71	1.75
1-1/2	5.24	1/4	7.91	6.10	M8	0.71	1.75
2	6.14	1/4	9.33	8.27	M8	0.71	1.75
2-1/2	9.92	1/4	12.01	10.16	M12	0.91	3.94
3	9.92	1/4	12.01	10.16	M12	0.91	3.94
4	10.55	1/4	12.99	10.16	M12	0.91	4.72

#### Normally Open & Air to Air – True Union Connections

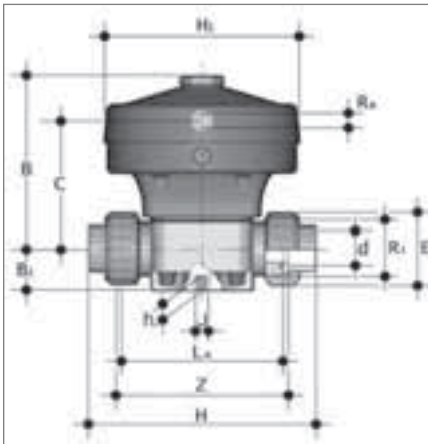

Size	Dimension (inches)							
	PVC / CPVC			PP / PVDF			LA	B1
d (in)	H	Z	d (mm)	H	Z			
1/2	0.84	6.30	4.53	20	5.79	4.53	4.25	1.02
3/4	1.05	6.57	4.53	25	6.06	4.57	4.25	1.02
1	1.32	7.09	4.80	32	6.61	4.88	4.57	1.02
1-1/4	1.66	8.19	5.67	40	7.56	5.51	5.28	1.57
1-1/2	1.90	9.21	6.46	50	8.74	6.30	6.06	1.57
2	2.38	10.71	7.68	63	10.47	7.48	7.24	1.57

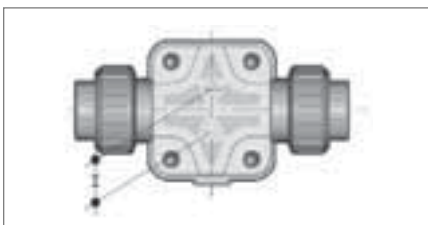

Size	Dimension (inches)								
	C	Ra	B	H1	E	R1	J	h	l
1/2	4.92	1/4	5.67	4.96	1.61	1	M6	0.47	0.98
3/4	4.92	1/4	5.67	4.96	1.97	1-1/4	M6	0.47	0.98
1	4.92	1/4	5.67	4.96	2.28	1-1/2	M6	0.47	0.98
1-1/4	5.43	1/4	7.91	6.10	2.83	2	M8	0.63	1.75
1-1/2	5.43	1/4	7.91	6.10	3.11	2-1/4	M8	0.63	1.75
2	6.34	1/4	9.33	8.27	3.86	2-3/4	M8	0.63	1.75

## VM SERIES PNEUMATIC DIAPHRAGM VALVES

### Dimensions (cont'd)

#### Normally Open & Air to Air – ANSI 150 Flanged (Vanstone) Connections

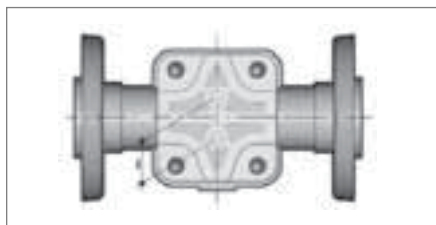
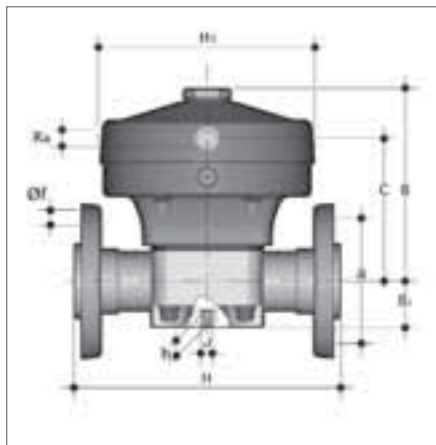

Size	Dimension (inches)						
	d	H	B1	C	Ra	B	H1
1/2	0.84	5.37	1.02	4.72	1/4	5.67	4.96
3/4	1.05	6.11	1.02	4.72	1/4	5.67	4.96
1	1.32	6.58	1.02	4.72	1/4	5.67	4.96
1-1/4	1.66	7.30	1.57	5.24	1/4	7.91	6.10
1-1/2	1.90	8.02	1.57	5.24	1/4	7.91	6.10
2	2.38	8.88	1.57	6.14	1/4	9.33	8.27
2-1/2	2.88	11.34	2.17	9.92	1/4	12.01	10.16
3	3.50	11.81	2.17	9.92	1/4	12.01	10.16
4	4.50	13.39	2.72	10.55	1/4	12.99	10.16

Size	Dimension (inches)					
	# holes	f	F	J	h	l
1/2	4	5/8	2-3/8	M6	0.47	0.98
3/4	4	5/8	2-3/4	M6	0.47	0.98
1	4	5/8	3-1/8	M6	0.47	0.98
1-1/4	4	5/8	3-1/2	M8	0.71	1.75
1-1/2	4	5/8	3-7/8	M8	0.71	1.75
2	4	3/4	4-3/4	M8	0.71	1.75
2-1/2	4	3/4	5-1/2	M12	0.91	3.94
3	4	3/4	6	M12	0.91	3.94
4	4	3/4	7-1/2	M12	0.91	4.72

## VM SERIES PNEUMATIC DIAPHRAGM VALVES

### Dimensions (cont'd)

#### Normally Closed – Spigot Connections

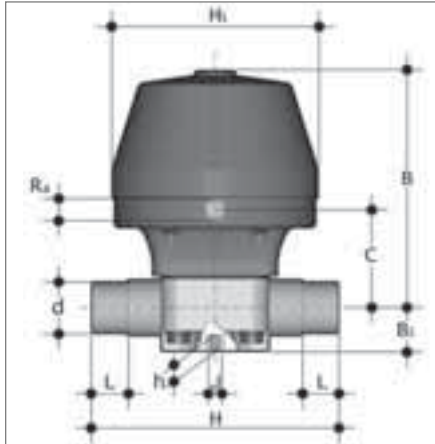

Size	Dimension (inches)				
	PVC / CPVC d (in)	PP / PVDF d (mm)	H	L	B1
1/2	0.84	20	4.88	0.63	1.02
3/4	1.05	25	5.67	0.75	1.02
1	1.32	32	6.06	0.87	1.02
1-1/4	1.66	40	6.85	1.02	1.57
1-1/2	1.90	50	7.64	1.22	1.57
2	2.38	63	8.82	1.50	1.57
2-1/2	2.88	75	11.18	1.73	2.17
3	3.50	90	11.81	2.01	2.17
4	4.50	110	13.39	2.40	2.72

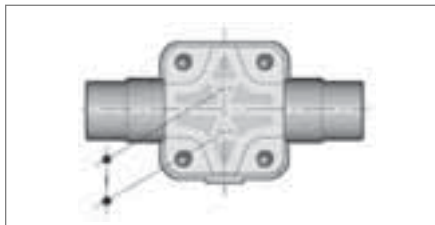

Size	Dimension (inches)						
	C	Ra	B	H1	J	h	l
1/2	2.60	1/4	6.89	4.96	M6	0.47	0.98
3/4	2.60	1/4	6.89	4.96	M6	0.47	0.98
1	2.60	1/4	6.89	4.96	M6	0.47	0.98
1-1/4	4.06	1/4	9.61	6.10	M8	0.71	1.75
1-1/2	4.06	1/4	9.61	6.10	M8	0.71	1.75
2	4.92	1/4	11.50	8.27	M8	0.71	1.75
2-1/2	7.36	1/4	12.80	10.16	M12	0.91	3.94
3	7.36	1/4	12.80	10.16	M12	0.91	3.94
4	10.55	1/4	13.98	10.16	M12	0.91	4.72

#### Normally Closed – True Union Connections

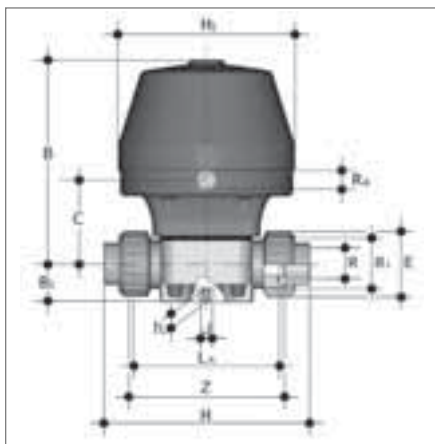

Size	Dimension (inches)							
	PVC / CPVC			PP / PVDF			LA	B1
	d (in)	H	Z	d (mm)	H	Z		
1/2	0.84	6.30	4.53	20	5.79	4.53	4.25	1.02
3/4	1.05	6.57	4.53	25	6.06	4.57	4.25	1.02
1	1.32	7.09	4.80	32	6.61	4.88	4.57	1.02
1-1/4	1.66	8.19	5.67	40	7.56	5.51	5.28	1.57
1-1/2	1.90	9.21	6.46	50	8.74	6.30	6.06	1.57
2	2.38	10.71	7.68	63	10.47	7.48	7.24	1.57

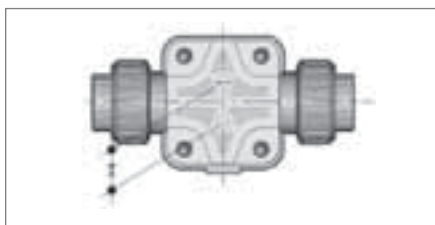

Size	Dimension (inches)								
	C	Ra	B	H1	E	R1	J	h	l
1/2	2.60	1/4	6.89	4.96	1.61	1	M6	0.47	0.98
3/4	2.60	1/4	6.89	4.96	1.97	1-1/4	M6	0.47	0.98
1	2.60	1/4	6.89	4.96	2.28	1-1/2	M6	0.47	0.98
1-1/4	4.06	1/4	9.61	6.10	2.83	2	M8	0.63	1.75
1-1/2	4.06	1/4	9.61	6.10	3.11	2-1/4	M8	0.63	1.75
2	4.92	1/4	11.50	8.27	3.86	2-3/4	M8	0.63	1.75

## VM SERIES PNEUMATIC DIAPHRAGM VALVES

### Dimensions (cont'd)

#### Normally Closed – ANSI 150 Flanged (Vanstone) Connections

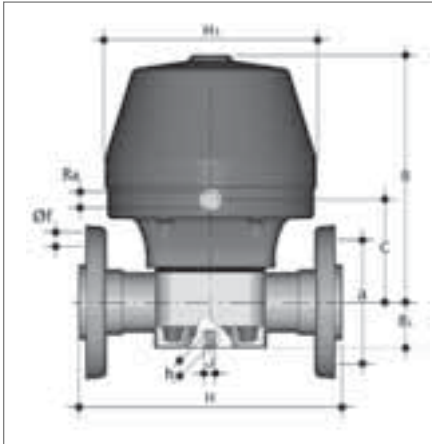

Size	Dimension (inches)						
	d	H	B1	C	Ra	B	H1
1/2	0.84	5.37	1.02	2.60	1/4	6.89	4.96
3/4	1.05	6.11	1.02	2.60	1/4	6.89	4.96
1	1.32	6.58	1.02	2.60	1/4	6.89	4.96
1-1/4	1.66	7.30	1.57	4.06	1/4	9.61	6.10
1-1/2	1.90	8.02	1.57	4.06	1/4	9.61	6.10
2	2.38	8.88	1.57	4.92	1/4	11.50	8.27
2-1/2	2.88	11.34	2.17	7.36	1/4	12.80	10.16
3	3.50	11.81	2.17	7.36	1/4	12.80	10.16
4	4.50	13.39	2.72	10.55	1/4	13.98	10.16

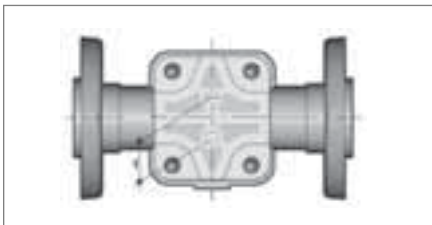

Size	# holes	Dimension (inches)				
		f	F	J	h	l
1/2	4	5/8	2-3/8	M6	0.47	0.98
3/4	4	5/8	2-3/4	M6	0.47	0.98
1	4	5/8	3-1/8	M6	0.47	0.98
1-1/4	4	5/8	3-1/2	M8	0.71	1.75
1-1/2	4	5/8	3-7/8	M8	0.71	1.75
2	4	3/4	4-3/4	M8	0.71	1.75
2-1/2	4	3/4	5-1/2	M12	0.91	3.94
3	4	3/4	6	M12	0.91	3.94
4	4	3/4	7-1/2	M12	0.91	4.72

DIAPHRAGM VALVES

### Diaphragm

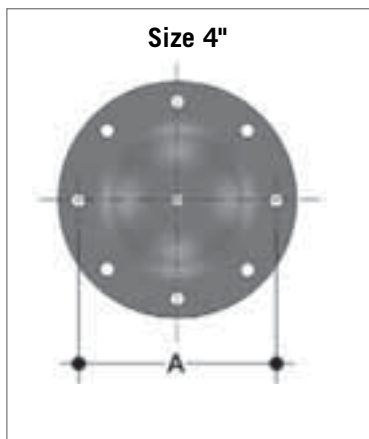
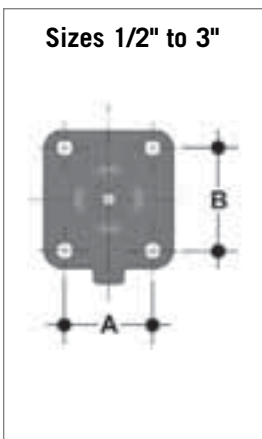

Size (inches)	Size (mm)	Dimension (inches)	
		A	B
1/2	20	1.81	2.13
3/4	25	1.81	2.13
1	32	1.81	2.13
1-1/4	40	2.56	2.76
1-1/2	50	2.56	2.76
2	63	3.07	3.23
2-1/2	75	4.49	5.00
3	90	4.49	5.00
4	110	7.60	-

## VM SERIES PNEUMATIC DIAPHRAGM VALVES

### Weights

Approximate Weight (lbs) – Normally Open & Air to Air										
Size (inches)	PVC			CPVC			PP		PVDF	
	Spigot	True Union	Flanged	Spigot	True Union	Flanged	Spigot	True Union	Spigot	True Union
1/2	2.87	3.15	3.25	2.91	3.22	3.31	2.65	2.89	3.02	3.65
3/4	2.87	3.15	3.39	2.91	3.30	3.46	2.65	2.98	3.02	3.80
1	2.87	3.15	3.59	2.91	3.37	3.67	2.65	3.04	3.02	3.94
1-1/4	6.17	6.61	7.09	6.31	6.66	7.27	5.51	6.00	6.63	7.46
1-1/2	6.17	6.61	7.39	6.31	6.83	7.59	5.51	6.08	6.63	7.66
2	10.14	11.02	12.16	10.36	11.28	12.48	9.04	10.10	10.83	12.45
2-1/2	27.56	n/a	30.36	28.13	n/a	31.07	25.35	n/a	29.40	n/a
3	28.66	n/a	31.83	29.23	n/a	32.56	26.46	n/a	30.37	n/a
4	48.50	n/a	53.69	49.29	n/a	54.74	45.19	n/a	51.01	n/a

Approximate Weight (lbs) – Normally Closed										
Size (inches)	PVC			CPVC			PP		PVDF	
	Spigot	True Union	Flanged	Spigot	True Union	Flanged	Spigot	True Union	Spigot	True Union
1/2	4.08	4.37	4.46	4.12	4.43	4.52	3.86	4.10	4.24	4.86
3/4	4.08	4.37	4.60	4.12	4.51	4.67	3.86	4.19	4.24	5.02
1	4.08	4.37	4.80	4.12	4.59	4.88	3.86	4.25	4.24	5.15
1-1/4	8.82	9.26	9.74	8.95	9.30	9.92	8.16	8.64	9.28	10.11
1-1/2	8.82	9.26	10.04	8.95	9.48	10.23	8.16	8.73	9.28	10.30
2	15.32	16.20	17.34	15.54	16.46	17.66	14.22	15.28	16.01	17.63
2-1/2	33.07	n/a	35.87	33.64	n/a	36.58	30.86	n/a	34.92	n/a
3	34.17	n/a	37.34	34.74	n/a	38.07	31.97	n/a	35.89	n/a
4	56.22	n/a	61.41	57.01	n/a	62.46	52.91	n/a	58.72	n/a

DIAPHRAGM VALVES

### Pressure – Temperature Ratings

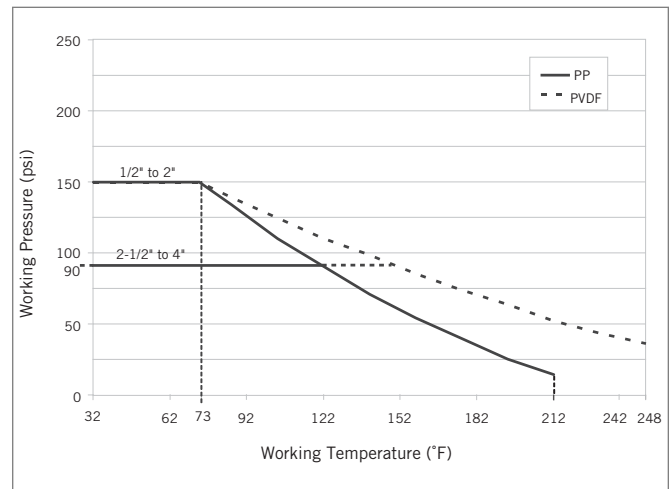
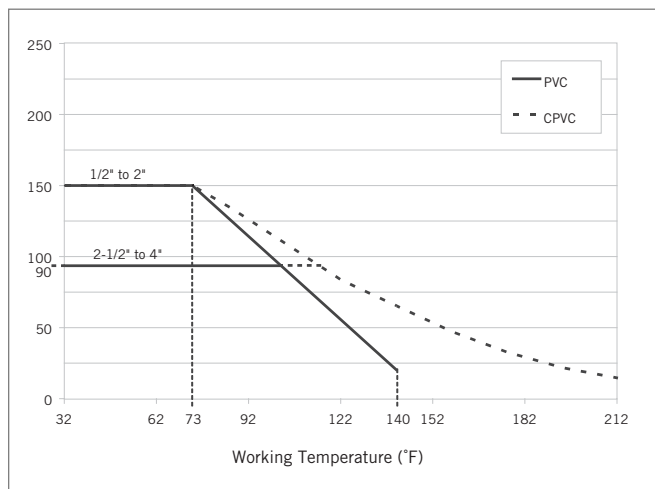

## VM SERIES PNEUMATIC DIAPHRAGM VALVES

### Control Pressure

**Normally Open & Air to Air**

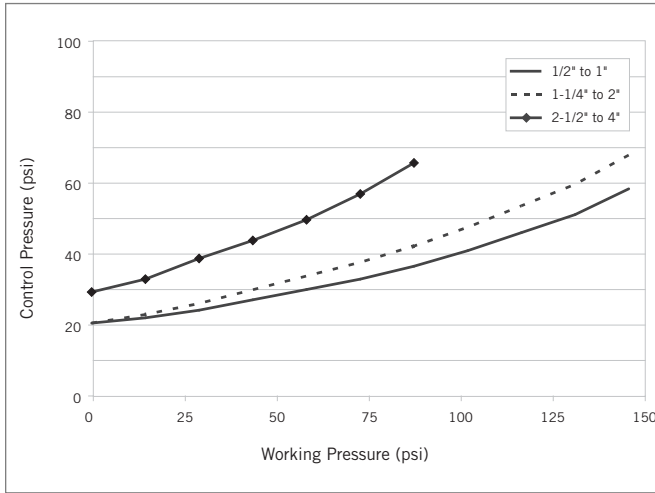

**Normally Closed**

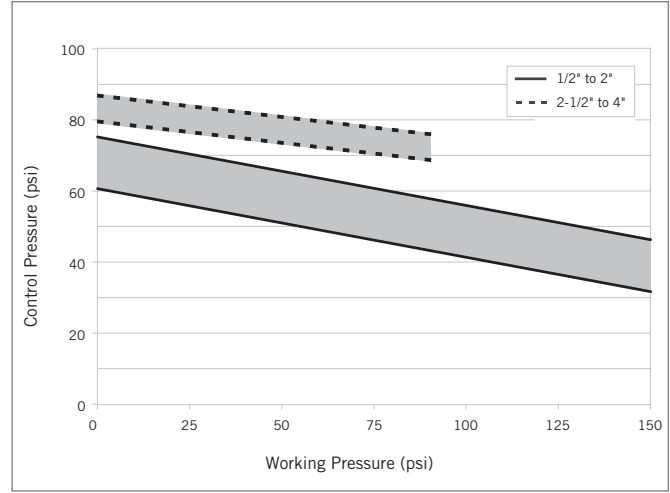

**Notes:**

- The maximum working pressure is 150psi for sizes 1/2" to 2" and 90psi for sizes 2-1/2" to 4".
- The maximum control pressure allowed for all sizes is 90psi.
- The control fluid temperature should not exceed 105°F.
- The fluid capacity of the actuator is 8 in<sup>3</sup> for sizes 1/2" to 1", 17 in<sup>3</sup> for sizes 1-1/4" to 1-1/2", 31 in<sup>3</sup> for size 2", and 134 in<sup>3</sup> for sizes 2-1/2" to 4".

**Notes:**

- The maximum working pressure is 150psi for sizes 1/2" to 2" and 90psi for sizes 2-1/2" to 4".
- The maximum control pressure allowed for all sizes is 90psi.
- The control fluid temperature should not exceed 105°F (40°C).
- The fluid capacity of the actuator is 10 in<sup>3</sup> for sizes 1/2" to 1", 22 in<sup>3</sup> for sizes 1-1/4" to 1-1/2", 70 in<sup>3</sup> for size 2", and 128 in<sup>3</sup> for sizes 2-1/2" to 4".

DIAPHRAGM VALVES

**Flow Coefficients**

Size (in)	C <sub>v</sub>
1/2	6.51
3/4	9.52
1	12.3
1-1/4	21.0
1-1/2	29.1
2	53.6
2-1/2	91.0
3	140
4	189

**Pressure Loss Chart**

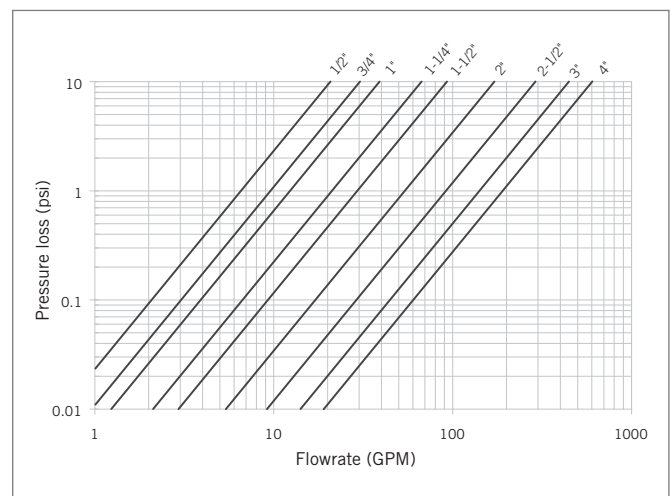

## VM SERIES PNEUMATIC DIAPHRAGM VALVES

### Components

#### Normally Open & Air to Air

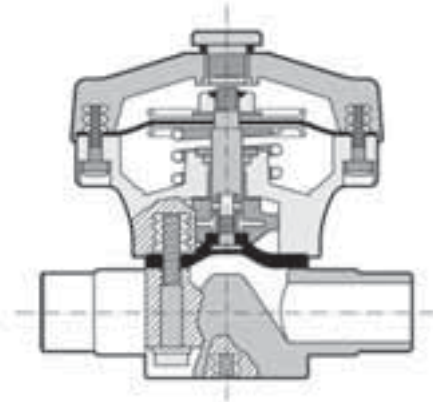
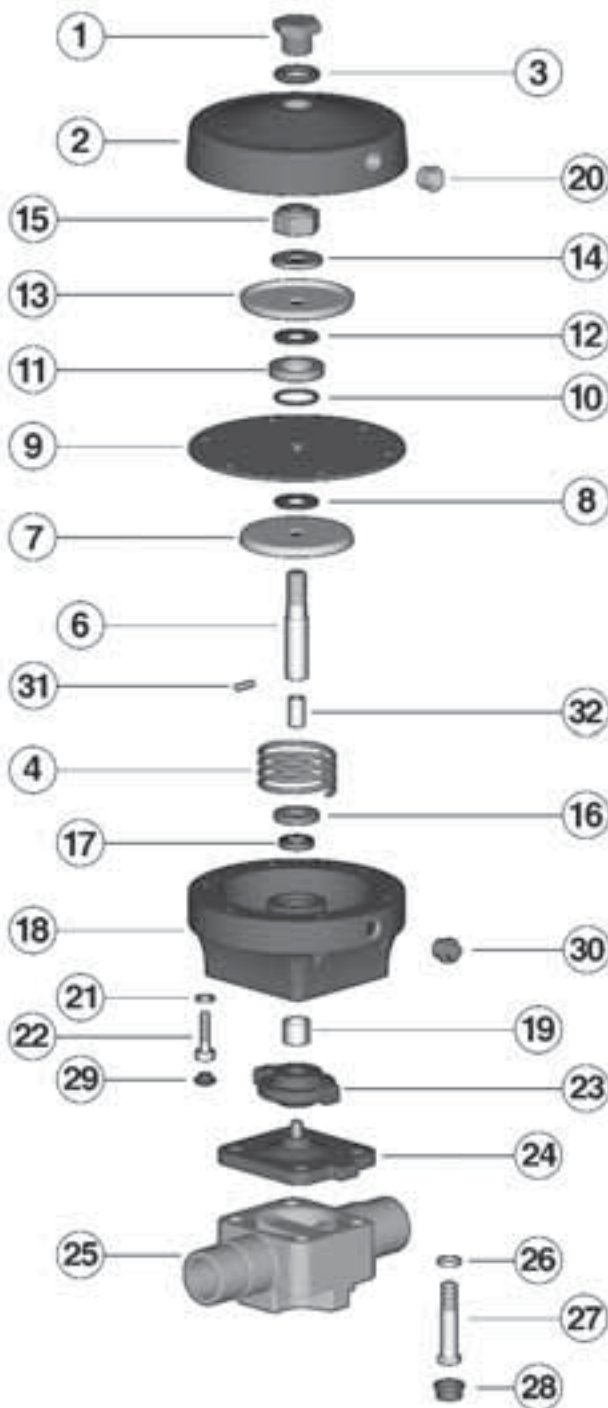

#	Component	Material	Qty
1	threaded plug	AL	1
2	actuator – upper part	GRPP	1
3	o-ring	NBR	1
4	spring	carbon steel	1
6	spindle	stainless steel	1
7	press diaphragm-plate	zinc plated steel	1
8	washer	NBR	1
9	control diaphragm	CR	1
10	o-ring (sizes 1-1/4" to 2")	NBR	1
11	spacer ring (sizes 1-1/4" to 2")	zinc plated steel	1
12	washer	NBR	1
13	press diaphragm-plate	zinc plated steel	1
14	washer	zinc plated steel	1
15	locknut	zinc plated steel	1
16	security washer	brass	1
17	quad-ring	NBR	1
18	actuator – lower part	GRPP	1
19	spindle bearing	metal – PTFE	1
20	plug	PE	1
21	washer	zinc plated steel	6
22	cylindrical screw	zinc plated steel	6
23	compressor	PBT	1
24	sealing diaphragm	EPDM / Viton® / PTFE	1
25	valve body	PVC / CPVC / PP / PVDF	1
26	washer	zinc plated steel <sup>1</sup>	4
27	hex bolt	zinc plated steel <sup>1</sup>	4
28	protective cap	PE	4
29	protective cap	PP	6
30	threaded plug	brass	1
31	pin (sizes 1/2" to 2")	SS	1
32	coupling	SS	1

\* Spare parts available. Items 1 through 7 are supplied as an assembly. Contact IPEX for availability of spare components for True Union and Flanged style valves.

<sup>1</sup> stainless steel for PVDF valves.

## VM SERIES PNEUMATIC DIAPHRAGM VALVES

### Components (cont'd)

#### Normally Closed

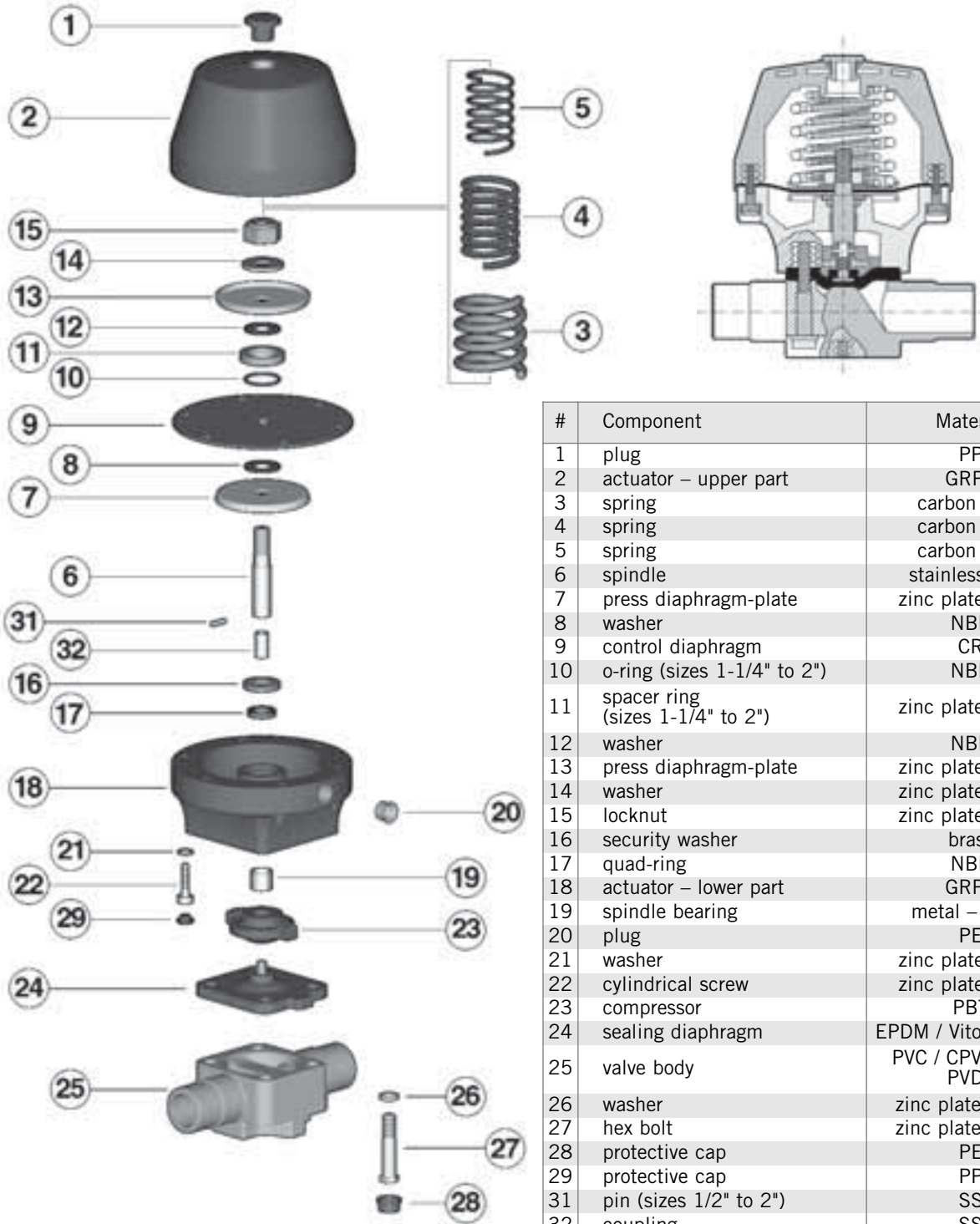

#	Component	Material	Qty
1	plug	PP	1
2	actuator – upper part	GRPP	1
3	spring	carbon steel	1
4	spring	carbon steel	1
5	spring	carbon steel	1
6	spindle	stainless steel	1
7	press diaphragm-plate	zinc plated steel	1
8	washer	NBR	1
9	control diaphragm	CR	1
10	o-ring (sizes 1-1/4" to 2")	NBR	1
11	spacer ring (sizes 1-1/4" to 2")	zinc plated steel	1
12	washer	NBR	1
13	press diaphragm-plate	zinc plated steel	1
14	washer	zinc plated steel	1
15	locknut	zinc plated steel	1
16	security washer	brass	1
17	quad-ring	NBR	1
18	actuator – lower part	GRPP	1
19	spindle bearing	metal – PTFE	1
20	plug	PE	1
21	washer	zinc plated steel	6
22	cylindrical screw	zinc plated steel	6
23	compressor	PBT	1
24	sealing diaphragm	EPDM / Viton® / PTFE	1
25	valve body	PVC / CPVC / PP / PVDF	1
26	washer	zinc plated steel <sup>1</sup>	4
27	hex bolt	zinc plated steel <sup>1</sup>	4
28	protective cap	PE	4
29	protective cap	PP	6
31	pin (sizes 1/2" to 2")	SS	1
32	coupling	SS	1

\* Spare parts available. Items 1 through 7 are supplied as an assembly. Contact IPEX for availability of spare components for True Union and Flanged style valves.

<sup>1</sup> stainless steel for PVDF valves.

## VM SERIES PNEUMATIC DIAPHRAGM VALVES

### Installation Procedures

1. The valve may be installed in any position or direction.
2. Please refer to the appropriate connection style subsection:
  - a. For spigot style, solvent cement each pipe onto the ends of the valve body (part #25 on previous page). Ensure that excess solvent does not run into the body of the valve.
  - b. For true union style, remove the union nuts and slide them onto the pipe.
    - i. For socket style, solvent cement the end connectors onto the pipe ends. For correct joining procedure, please refer to the section entitled, *“Joining Methods - Solvent Cementing”* in the IPEX Industrial Technical Manual Series, *“Volume I: Vinyl Process Piping Systems”*. Ensure that excess solvent does not run into the body of the valve. **Be sure to allow sufficient cure time before continuing with the valve installation.**
    - ii. For threaded style, thread the end connectors onto the pipe ends. For correct joining procedure, please refer to the section entitled, *“Joining Methods - Threading”* in the IPEX Industrial Technical Manual Series, *“Volume I: Vinyl Process Piping Systems”*.
    - iii. Ensure that the socket o-rings are properly fitted in their grooves then carefully place the valve in the system between the two end connections.
    - iv. Tighten both union nuts. Hand tightening is typically sufficient to maintain a seal for the maximum working pressure. Over-tightening may damage the threads on the valve body and/or the union nut, and may even cause the union nut to crack.
  - c. For flanged style, join both flanges to the pipe flanges. For correct joining procedure, please refer to the section entitled, *“Joining Methods - Flanging”* in the IPEX Industrial Technical Manual Series, *“Volume I: Vinyl Process Piping Systems”*.
3. Anchoring is strongly recommended due to the weight of the actuator. The valve can be fixed to the supporting structure using the mounting holes on the bottom of the valve body.
4. Connect any accessories then a suitable air supply and pilot system to the actuator. Be sure to check that both the working and control pressure are in accordance with the specifications.

## VM SERIES PNEUMATIC DIAPHRAGM VALVES

### Valve Maintenance

#### Disassembly

1. If removing the valve from an operating system, isolate the valve from the rest of the line. **Be sure to depressurize and drain the valve and isolated branch.** Depressurize and disconnect the pneumatic control line before continuing with disassembly.
2. Detach the valve from the support structure by disassembling the threaded connections on the bottom of the valve body (25).
3. Please refer to the appropriate connection style sub-section:
  - a. For spigot style, cut the pipe on either side of the valve and remove from the line.
  - b. For true union connections, loosen both union nuts and drop the valve out of the line. If retaining the socket o-rings, take care that they are not lost when removing the valve from the line.
  - c. For flanged style, loosen each bolt holding the valve to the pipe flanges. Please refer to the section entitled, “*Joining Methods - Flanging*” in the IPEX Industrial Technical Manual Series, “*Volume 1: Vinyl Process Piping Systems*” for a recommended bolt tightening pattern diagram. Follow the same pattern when disassembling the flanged joints then carefully remove the valve from the line.
4. Remove the protective caps (28), then loosen and remove the bolts (27) and washers (26) from the bottom of the valve body.
5. The valve components can now be checked for problems and/or replaced.

**Note:** For safety reasons, it is not recommended to attempt to disassemble the actuator. However if necessary, proceed as follows:

6. Using a spring release (or press) to maintain pressure on the internal springs, remove the protective caps (29) then carefully loosen and remove the bolts (22) and washers (21).
7. Back off the pressure on the spring release (or press) to separate the upper (2) and lower (18) parts of the actuator and remove the springs (4 for Normally Open, 3-5 for Normally Closed).
8. Loosen and remove the locknut (15) to disassemble the diaphragm control components (7 through 14).
9. Remove the spindle (6, 31, and 32) - compressor (23) - diaphragm (24) assembly, taking care not to damage the quad-ring (17).
10. Loosen and remove both the diaphragm and compressor.

#### Assembly

**Note:** Before assembling the valve components, it is advisable to lubricate the o-rings with a water soluble lubricant. **Be sure to consult the “IPEX Chemical Resistance Guide” and/or other trusted resources to determine specific lubricant-rubber compatibilities.**

1. Assemble the compressor (23) with the diaphragm (24) and thread onto the spindle (6, 31, and 32).
2. Insert the spindle into the lower part (18) of the actuator, ensuring proper placement of the quad-ring (17).
3. For Normally Open actuators, reposition the spring (4) in the lower part of the actuator.
4. Properly assemble the diaphragm control components (7-14) on the spindle and fasten in place using the locknut (15).
5. Carefully line up the holes of the control diaphragm (9) with the proper holes of the lower part of the actuator.
6. For Normally Closed actuators, reposition the springs (3-5) on the press-diaphragm plate (13).
7. Properly position the upper part (2) of the actuator on the lower portion, then clamp in place using a spring release tool or press. Insert and tighten all bolts (22) and washers (21) then replace all protective caps (29).
8. Sufficiently tighten the diaphragm (24) then back off slightly until the bolt holes line up.
9. Position the assembled actuator on the valve body (25) while ensuring that the sealing surfaces properly line up. Insert and tighten all bolts (27) and washers (26) then replace all protective caps (28).

## DV SERIES DIAPHRAGM VALVES

IPEX DV Series Diaphragm Valves are rugged industrial products ideal for throttling or use in abrasive slurry lines. The raising position indicator also functions as an adjustable travel stop. This feature can be used to avoid over-compression of the diaphragm, or as a travel limiter allowing different settings for the “closed” position. The molded flanged body eliminates potentially leaky joints while featuring end-to-end dimensions identical to most plastic lined metal diaphragm valves, allowing for direct replacement. DV Series Diaphragm Valves are part of our complete Xirtec®140 systems of pipe, valves, and fittings, engineered and manufactured to our strict quality, performance, and dimensional standards.

### Valve Availability

Body Material:	PVC
Size Range:	1/2" through 6"
Pressure:	150psi
Diaphragm:	EPDM, Viton® (PTFE)
Control Style:	Manual Handwheel
End Connections:	Flanged (ANSI 150)



ASTM D1784



ANSI B16.5

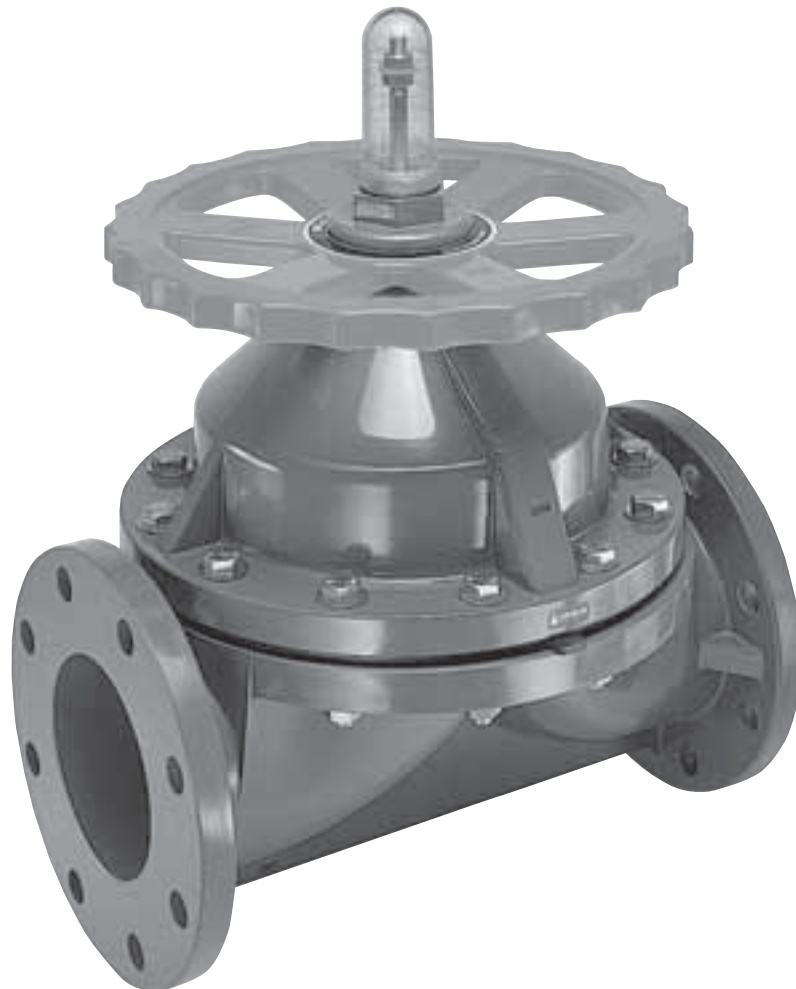

## DV SERIES DIAPHRAGM VALVES

### Sample Specification

#### 1.0 Diaphragm Valves - DV

##### 1.1 Material

- The valve body shall be made of PVC compound which shall meet or exceed the requirements of cell classification 12454 according to ASTM D1784.

##### 1.2 Diaphragm

- The diaphragm shall be made of EPDM.
- or The diaphragm shall be made of Teflon® (PTFE).

- 1.3** All wetted parts of the valves shall comply with standards that are equivalent to NSF Standard 61 for potable water.

#### 2.0 Connections

##### 2.1 Flanged style

- The ANSI 150 flanged PVC end connections shall conform to the dimensional standard ANSI B16.5.

#### 3.0 Design Features

- All valves shall have integrally molded flanged ends.
- All valves shall have a clear position indicator.
- All valves shall have an adjustable travel stop.
- All valves shall have face-to-face dimensions to the industry standard.
- The valve shall have no wetted metal parts.
- Service of the valve shall be possible without removal from the system line.

##### 3.1 Pressure Rating

- Valve sizes 1/2" through 3" shall be rated at 150psi at 73°F (23°C).
- Valve sizes 4" through 6" shall be rated at 75psi at 73°F (23°C).

##### 3.2 Markings

- All valves shall be marked to indicate size, material designation, and manufacturers name or trade mark.

##### 3.3 Color Coding

- All PVC valves shall be color-coded dark gray.
- All hand wheels shall be color-coded red.

- 4.0** All valves shall be Xirtec® 140 by IPEX or approved equal.

## DV SERIES DIAPHRAGM VALVES

### Pressure – Temperature Ratings

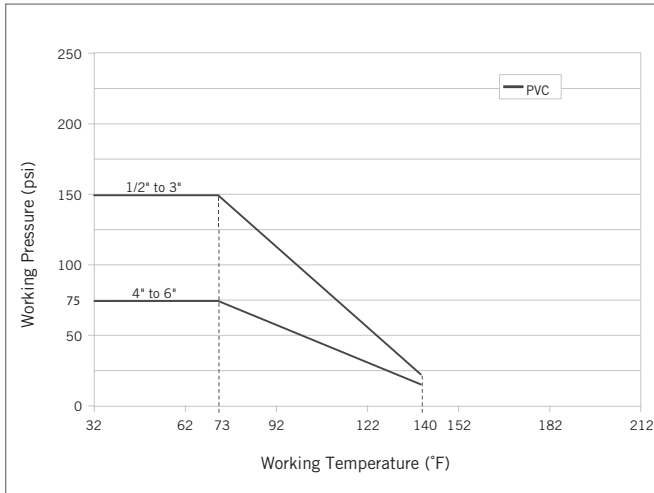

### Flow Coefficients

Size	C <sub>v</sub>
1/2	3.27
3/4	5.29
1	8.87
1-1/2	31.1
2	43.2
3	117
4	187
6	345

### Pressure Loss Chart

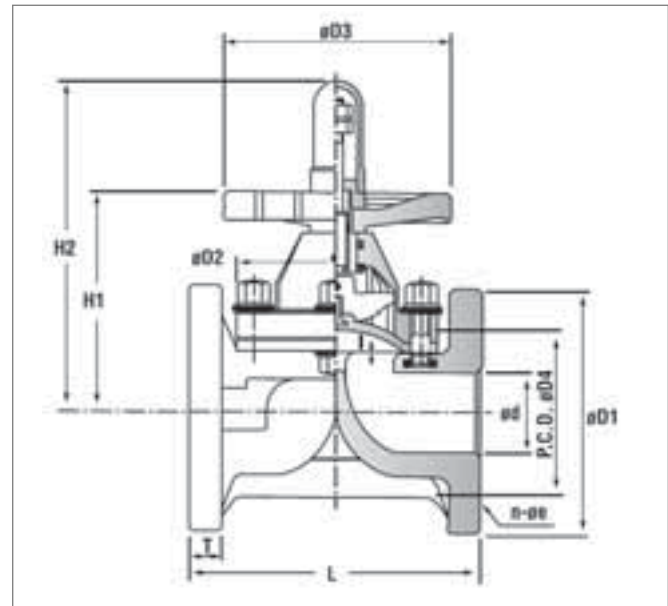
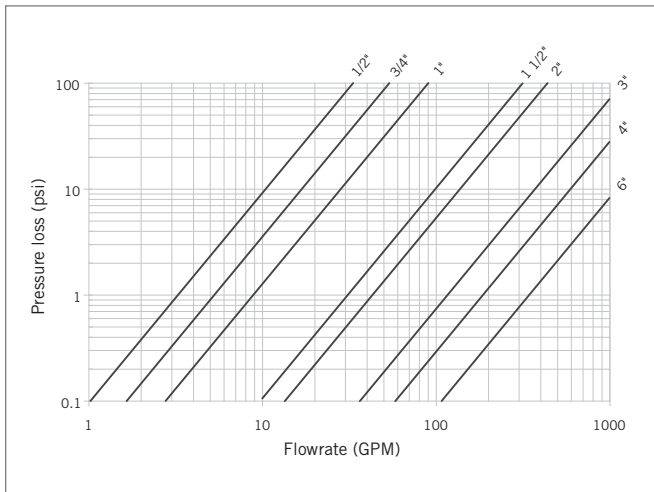

DIAPHRAGM VALVES

### Dimensions and Weights

Size	Dimension (inches)											W (lbs)
	D1	D2	D3	D4	d	H1	H2	L	l	n-fe	T	
1/2	3.50	2.13 x 2.76	3.74	2.36	0.51	3.35	4.96	4.25	0.39	4-0.63	0.51	1.79
3/4	3.86	2.48 x 3.07	3.74	2.76	0.71	3.70	5.39	5.91	0.47	4-0.63	0.59	2.20
1	4.25	2.48 x 3.46	4.33	3.11	0.98	3.86	5.67	5.91	0.59	4-0.63	0.52	3.67
1-1/2	5.00	4.92	5.91	3.86	1.61	5.12	8.66	6.93	0.87	4-0.63	0.67	4.91
2	5.98	5.83	5.91	4.76	2.05	5.83	8.86	7.95	1.22	4-0.75	0.67	6.45
3	7.52	7.99	8.27	5.98	3.07	9.84	13.50	10.39	1.89	4-0.75	0.79	15.43
4	9.02	10.04	9.84	7.52	3.94	10.83	15.08	12.95	2.36	8-0.75	0.87	24.25
6	10.98	15.16	16.14	9.49	5.83	13.15	18.74	18.90	2.76	8-0.87	0.94	65.04

## DV SERIES DIAPHRAGM VALVES

### Components

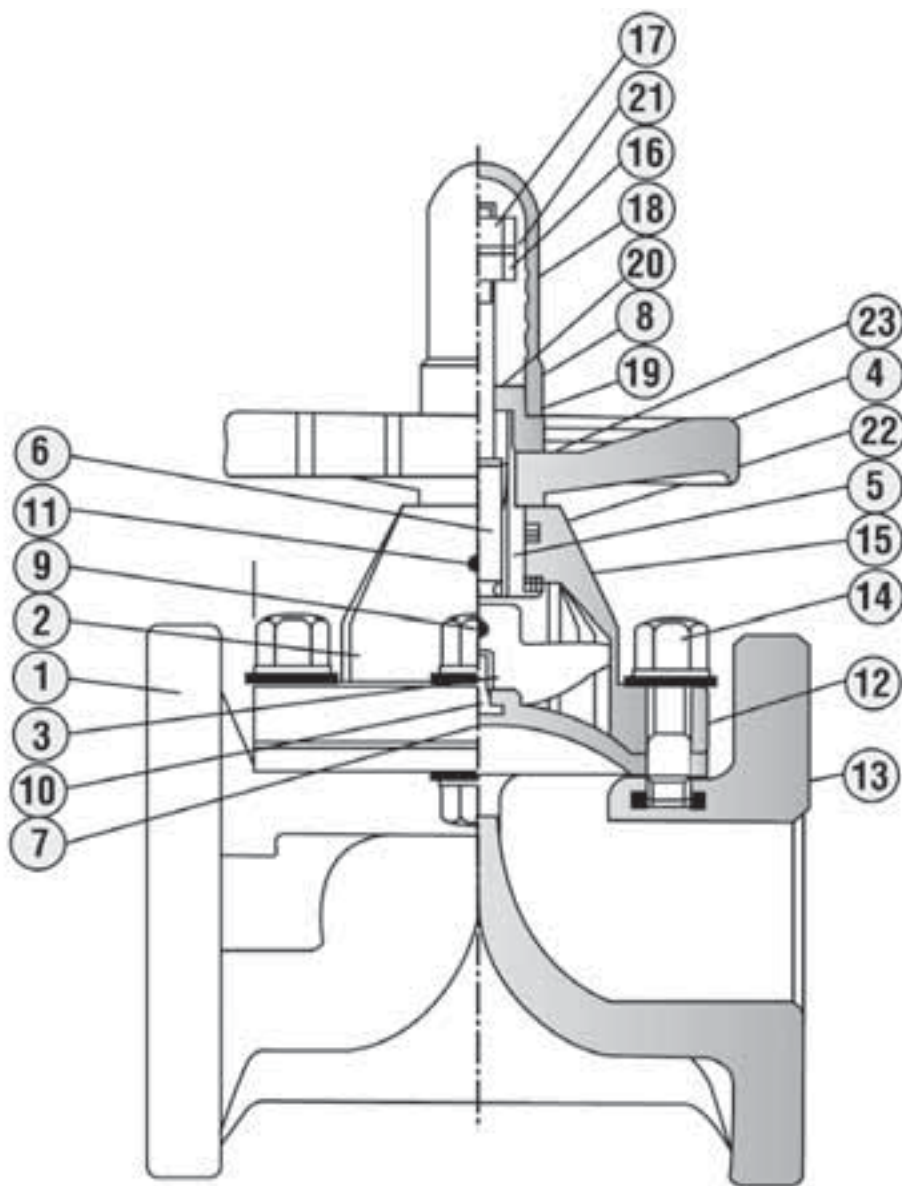

#	Component	Material	Qty
1	body	PVC	1
2	bonnet	PVC	1
3	compressor	FC, SUS	1
4	hand wheel	PP	1
5	sleeve	C3602	1
6	stem	C3602	1
7	diaphragm	EPDM or Teflon®	1
8	cap	PVC	1
9	compressor pin	SUS 304	1
10	inserted metal	C3604, SUS 304	1
11	grease nipple	C3604 (65-150)	1
12	bolt & washer	150	12 ea

#	Component	Material	Qty
13	inserted nut	65-125	8 ea
14	nut & washer	25-50	6 ea
15	thrust bearing	Standard (100-150)	1
16	stopper nut	SUS 304	1
17	set nut	SUS304	1
18	gauge cover	AS	1
19	sheet gasket	EPDM	1
20	sheet ring	SUS 304	1
21	spring washer	SUP	1
22	o-ring	NBR	1
23	name plate	PVC	1

## DV SERIES DIAPHRAGM VALVES

### Installation Procedures

1. Remove the protective seals from either end of the valve then carefully place into the system between the two pipe flanges.
2. Join each end of the valve to the pipe flanges. For correct joining procedure, please refer to the section entitled, *“Joining Methods – Flanging”* in the IPEX Industrial Technical Manual Series, *“Volume I: Vinyl Process Piping Systems”*.

### Travel Stop Adjustment

1. Loosen and remove the gauge cover (part #18 on previous page) from the position indicator assembly.
2. Remove and set aside the sheet gasket (19).
3. Loosen the stopper nut (16), spring washer (21), and set nut (17) from the stem (6).
4. Tighten the handwheel (4) slightly until the diaphragm completely seals.
5. Tighten down the stopper nut until it just touches the cap (8), then tighten the set nut and spring washer accordingly.
6. Fit the sheet gasket over the stem and down onto the cap, then replace the gauge cover and tighten.

**Note:** It is important not to over-tighten the valve during calibration as it may cause permanent damage to the diaphragm. The valve is completely closed when the handwheel cannot turn any further without using excessive torque.



## DV SERIES DIAPHRAGM VALVES

### Valve Maintenance

#### Disassembly

1. If removing the valve from an operating system, isolate the valve from the rest of the system. **Be sure to depressurize and drain the isolated branch and valve before continuing.**
2. Loosen end of the valve from the pipe flanges. Please refer to the section entitled, “*Joining Methods – Flanging*” in the IPEX Industrial Technical Manual Series, “*Volume I: Vinyl Process Piping Systems*” for a recommended bolt tightening pattern diagram. Follow the same pattern when disassembling the flanged joints then carefully remove the valve from the line.
3. Ensure that the valve is in the fully open position.
4. Loosen and remove the gauge cover (part #18 on previous page) and the sheet gasket (19) from the position indicator assembly.
5. Loosen and remove the stopper nut (16), spring washer (21), and set nut (17) from the stem (6).
6. Loosen and remove the cap (8) then the handwheel (4).
7. Loosen and remove all bolts (12), nuts (14), and washers, then remove the bonnet – diaphragm assembly from the body (1).
8. To remove the diaphragm (7) from the bonnet (2), grip and gently turn in a counterclockwise direction.
9. To remove the compressor (3) from the bonnet, temporarily replace the handwheel and turn in a clockwise direction. The compressor will start to emerge from the cavity in the bonnet and eventually become loose enough to remove.
10. To remove the sleeve (5), gently push it into the cavity of the bonnet from above.
11. The valve components can now be checked for problems and/or replaced.

#### Assembly

**Note:** Before assembling the valve components, it is advisable to lubricate the o-rings with a water soluble lubricant. **Be sure to consult the “IPEX Chemical Resistance Guide” and/or other trusted resources to determine specific lubricant-rubber compatibilities.**

1. Insert the sleeve (5) into the cavity of the bonnet (2) and push firmly into place.
2. Insert the compressor (3) into the bonnet (2) and gently rotate a few turns in a counterclockwise direction until the threads grip and the moldings line up with those on the bonnet.
3. Temporarily place the handwheel (4) on the bonnet assembly and rotate in a counterclockwise direction until the compressor is fully retracted into the cavity in the bonnet.
4. Insert the integral screw on the diaphragm (7) into the compressor and turn in a clockwise direction until tight then back off two full turns.
5. Line up the holes on the diaphragm with those on the bonnet then gently push on the center of the diaphragm to ensure that the sleeve is properly fitted in the bonnet cavity. If the diaphragm is installed too tight, the sleeve will be pulled back into the bonnet cavity making installation of the handwheel impossible.
6. Place the bonnet – diaphragm assembly on the body (1) then fasten with all bolts (12), nuts (14), and washers. It is recommended to tighten the bolts in a diagonal pattern to ensure even stress distribution and optimal sealing of the diaphragm.
7. Fit the handwheel on the bonnet, fasten in position with the cap (8), and then turn until the diaphragm completely seals.
8. Thread the stopper nut (16) onto the stem (6) then tighten down until it just touches the cap.
9. Place the spring washer (21) and set nut (17) on the stem and tighten down accordingly.
10. Fit the sheet gasket (19) over the stem and down onto the cap, then replace the gauge cover (18) and tighten.



## CM SERIES COMPACT DIAPHRAGM VALVES

IPEX CM Series Compact Diaphragm Valves have an efficient design and are ideal for OEMs. A variety of body and diaphragm materials plus the option of pneumatic actuation combine to make this valve the perfect choice in a wide range of applications. A standard position indicator and integrated mounting bushings complete the long list of features. CM Series Compact Diaphragm Valves are part of our complete Xirtec®140, Corzan® and SFPP systems of pipe, valves, and fittings, engineered and manufactured to our strict quality, performance, and dimensional standards.



ASTM D1784  
ASTM D2466  
ASTM D2467  
ASTM D3222  
ASTM D4101  
ASTM F439



ISO 10931  
ISO 11922-1

### Valve Availability

Body Material:	PVC, CPVC, PP, PVDF
Size Range:	1/2" Metric 16mm & 20mm
Pressure:	90psi
Diaphragm:	EPDM, Viton® (FPM) or PTFE (EPDM backed)
Control Style:	Manual Handwheel or Pneumatically Actuated
End Connections:	True Union (Socket) Socket (Metric) Spigot (Metric)



## CM SERIES COMPACT DIAPHRAGM VALVES

### Sample Specification

#### 1.0 Diaphragm Valves - CM

##### 1.1 Material

- The valve body, including end connectors and unions shall be made of PVC compound which shall meet or exceed the requirements of cell classification 12454 according to ASTM D1784.
- or The valve body, including end connectors and unions shall be made of Corzan® CPVC compound which shall meet or exceed the requirements of cell classification 23447 according to ASTM D1784.
- or The valve body, including end connectors and unions shall be made of stabilized PP homopolymer compound, also containing a RAL 7032 pigment, which shall meet or exceed the requirements of Type I Polypropylene according to ASTM D4101.
- or The valve body, including end connectors and unions shall be made of virgin, non-regrind PVDF compound which shall meet or exceed the requirements of Table 1 according to ASTM D3222.
- The valve bonnet assembly shall be made of reinforced polyamide (nylon).

##### 1.2 Diaphragm

- The diaphragm shall be made of EPDM.
- or The diaphragm shall be made of Viton® (FPM).
- or The diaphragm shall be made of PTFE (backed with EPDM).

- 1.3 All wetted parts of the valves shall comply with standards that are equivalent to NSF Standard 61 for potable water.

#### 2.0 Connections

##### 2.1 Socket style

- The IPS socket PVC end connectors shall conform to the dimensional standards ASTM D2466 and ASTM D2467.
- or The IPS socket CPVC end connectors shall conform to the dimensional standard ASTM F439.
- or The Metric socket PP end connectors shall conform to the dimensional standard ISO 11922-1.
- or The Metric socket PVDF end connectors shall conform to the dimensional standard ISO 10931.

##### 2.2 Spigot style

- The Metric spigot PP end connectors shall conform to the dimensional standard ISO 11922-1.
- or The Metric spigot PVDF end connectors shall conform to the dimensional standard ISO 10931.

#### 3.0 Design Features

- All valves shall be weir-style for throttling applications.
- All bodies to be used with EPDM or Viton® diaphragms shall feature raised molded sealing rings (concentric).
- All bodies to be used with PTFE diaphragms shall be machined flat.
- All PTFE diaphragms shall feature a raised molded ring to combine sealing performance and longer life.
- All through bolts shall be made of 304 stainless steel.
- Bolts will thread directly into integrally molded brass inserts in the bonnet.
- All manual valves shall have a rising position indicator.
- Bodies of all sizes and materials shall have mounting brass inserts.

#### 3.1 Actuators

- All actuators shall be made of reinforced polyamide (nylon).
- All actuators shall feature a smooth top (no nut holes) for cleanliness.
- The edge of the actuator membrane shall be inside of the actuator protective housing.
- All springs shall be cut from spring grade steel for maximum memory life and epoxy coated for maximum chemical resistance.
- The following accessories shall be available for all actuators: position indicator, stroke limiter, stroke limiter with position indicator, limit switch, limit switch box, 3-15psi positioner, 4-20 mA positioner, solenoid pilot valve.

#### 3.2 Pressure Rating

- All valves shall be rated at 90psi at 73°F (23°C).

#### 3.3 Markings

- All valves shall be marked to indicate size, material designation, and manufacturers name or trade mark.

#### 3.4 Color Coding

- All PVC valves shall be color-coded dark gray.
- or All CPVC valves shall be color-coded light gray.
- or All PP valves shall be color-coded beige gray.
- or All PVDF valves shall not be color-coded and be white in appearance.

- 4.0 All valves shall be Xirtec® 140, Corzan®, PP or PVDF by IPEX or approved equal.

## CM SERIES COMPACT DIAPHRAGM VALVES

### Dimensions - Manual Control

#### True Union Connections

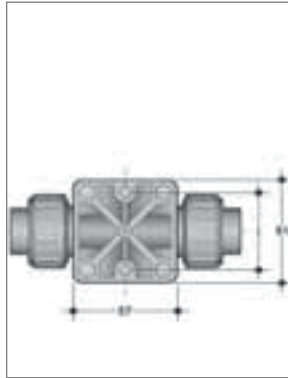
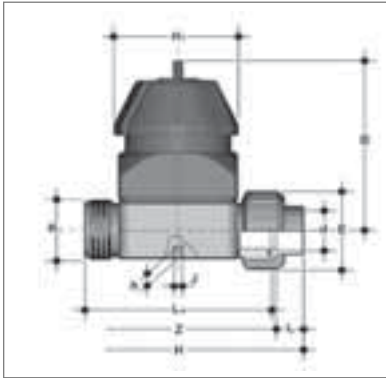

Dimension (inches)						
Size	H	Z	L	LA	R1	E
1/2"	5.10	3.84	0.63	3.54	1"	1.61
20mm	5.10	3.84	0.63	3.54	1"	1.61

Dimension (inches)					
Size	B	H1	h	J	I
1/2"	3.33	2.32	0.31	M5	1.38
20mm	3.33	2.32	0.31	M5	1.38

#### Socket Connections

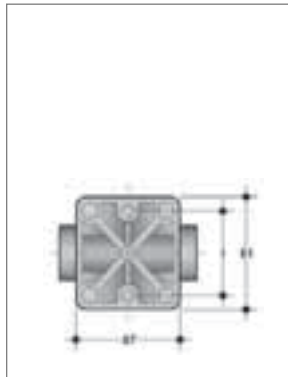
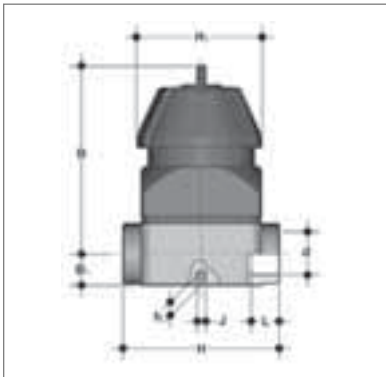

Dimension (inches)					
Size	d	H	L	B1	B
16mm	0.68	2.95	0.55	0.59	3.33

Dimension (inches)				
Size	H1	h	J	I
16mm	2.32	0.31	M5	1.38

#### Spigot Connections

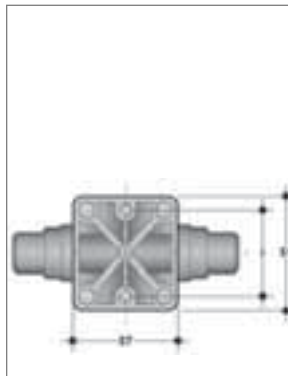
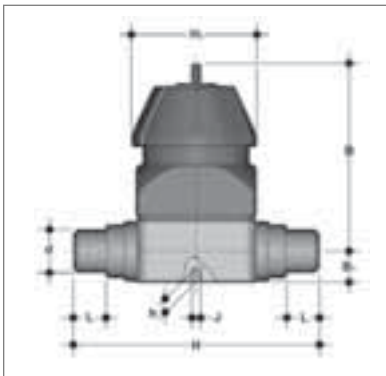

Dimension (inches)					
Size	d	H	L	B1	B
20mm	0.84	4.88	0.67	0.59	3.33

Dimension (inches)				
Size	H1	h	J	I
20mm	2.32	0.31	M5	1.38

## CM SERIES COMPACT DIAPHRAGM VALVES

### New Manual Bonnet

**Note:** As of July 2005, all new CM Manual valves are assembled with the bonnet shown below. The dimensions of the valve body and connections remain the same.

### Dimensions - Manual Control

#### True Union Connections

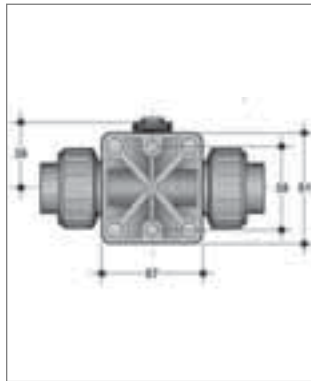
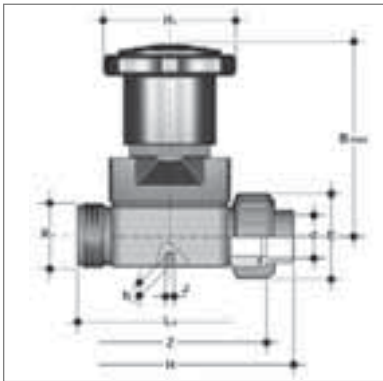

Dimension (inches)						
Size	H	Z	L	LA	R1	E
1/2"	5.10	3.84	0.63	3.54	1"	1.61
20mm	5.10	3.84	0.63	3.54	1"	1.61

Dimension (inches)					
Size	B	H1	h	J	I
1/2"	3.39	2.28	0.31	M5	1.38
20mm	3.39	2.28	0.31	M5	1.38

#### Socket Connections

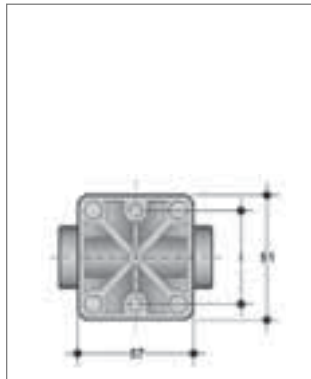
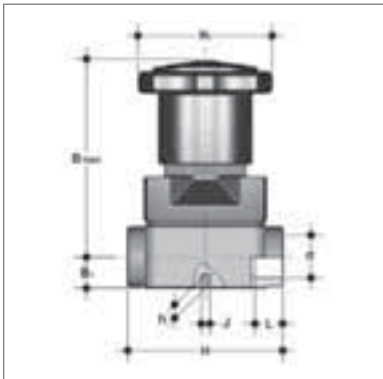

Dimension (inches)					
Size	d	H	L	B1	B
16mm	0.68	2.95	0.55	0.59	3.39

Dimension (inches)				
Size	H1	h	J	I
16mm	2.28	0.31	M5	1.38

#### Spigot Connections

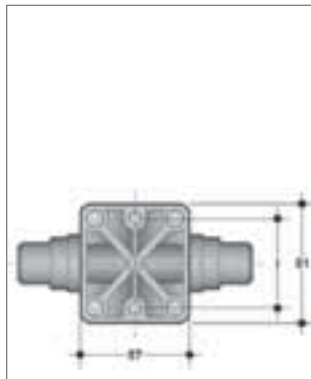
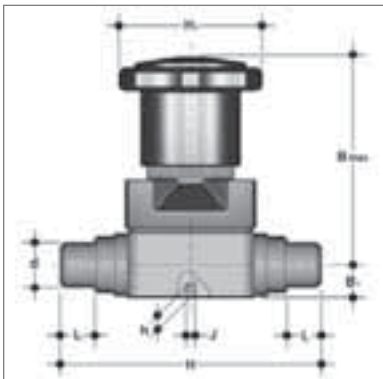

Dimension (inches)					
Size	d	H	L	B1	B
20mm	0.84	4.88	0.67	0.59	3.39

Dimension (inches)				
Size	H1	h	J	I
20mm	2.28	0.31	M5	1.38

## CM SERIES COMPACT DIAPHRAGM VALVES

### Dimensions - Pneumatic Control

#### True Union Connections

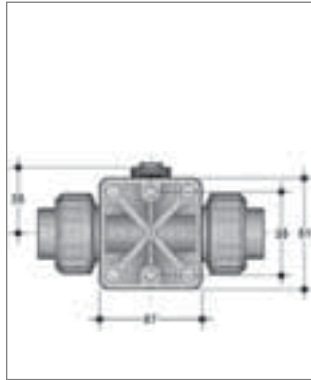
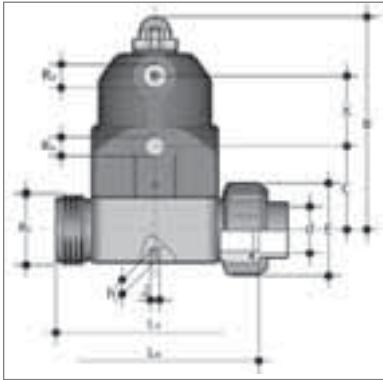

Dimension (inches)						
Size	d	LA	LB	R1	E	B
1/2"	0.84	3.54	3.78	1	1.61	3.86
20mm	0.84	3.54	3.78	1	1.61	3.86

Dimension (inches)					
Size	C	X	Ra	h	J
1/2"	1.50	1.34	1/8	0.31	M5
20mm	1.50	1.34	1/8	0.31	M5

#### Socket Connections

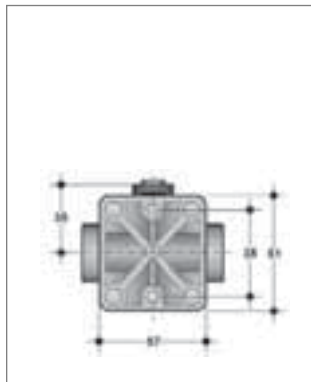
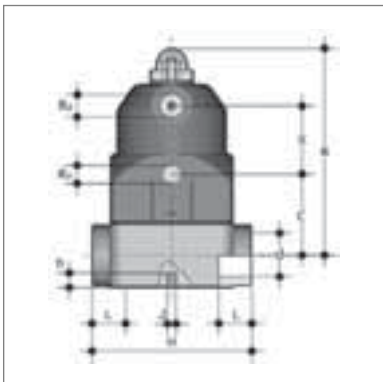

Dimension (inches)					
Size	d	H	L	B1	B
16mm	0.68	2.95	0.55	0.59	3.86

Dimension (inches)					
Size	C	X	Ra	h	J
16mm	1.50	1.34	1/8	0.31	M5

#### Spigot Connections

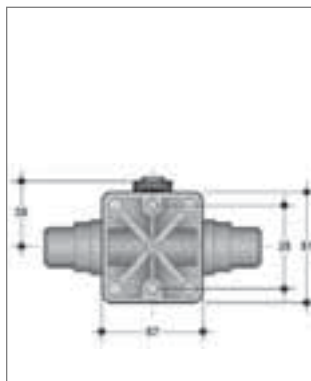
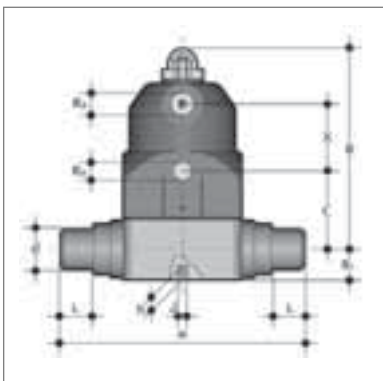

Dimension (inches)					
Size	d	H	L	B1	B
20mm	0.84	4.88	0.63	0.49	3.86

Dimension (inches)					
Size	C	X	Ra	h	J
16mm	1.50	1.34	1/8	0.31	M5

## CM SERIES COMPACT DIAPHRAGM VALVES

### Weights

Approximate Weight (lbs) - Manual Control					
Style	Size	PVC	CPVC	PP	PVDF
True Union	1/2"	0.63	0.64	-	-
	20mm	-	-	0.54	0.69
Socket	16mm	-	-	0.52	0.64
Spigot	20mm	-	-	0.58	0.75

Approximate Weight (lbs) - Pneumatic Control					
Style	Size	PVC	CPVC	PP	PVDF
True Union	1/2"	0.69	0.71	-	-
	20mm	-	-	0.61	0.75
Socket	16mm	-	-	0.59	0.71
Spigot	20mm	-	-	0.65	0.82

### Pressure – Temperature Ratings

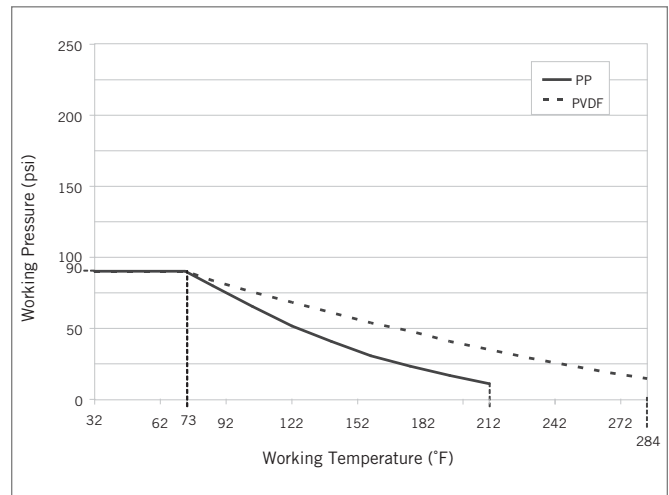
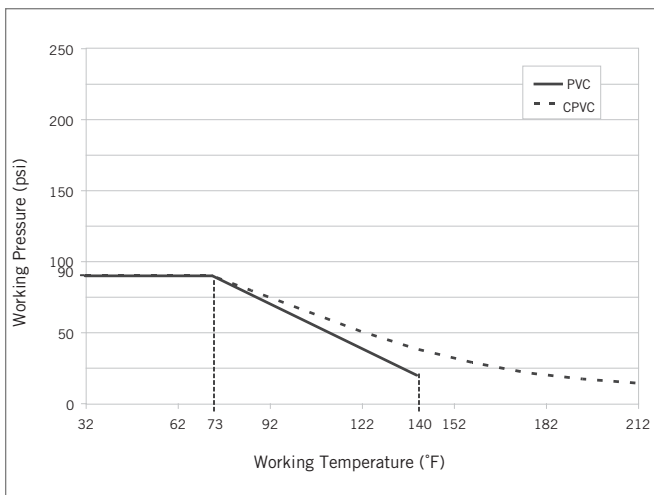

DIAPHRAGM VALVES

### Flow Coefficients

Size	C <sub>v</sub>
16mm	3.29
20mm	4.20
1/2"	4.20

### Pressure Loss Chart

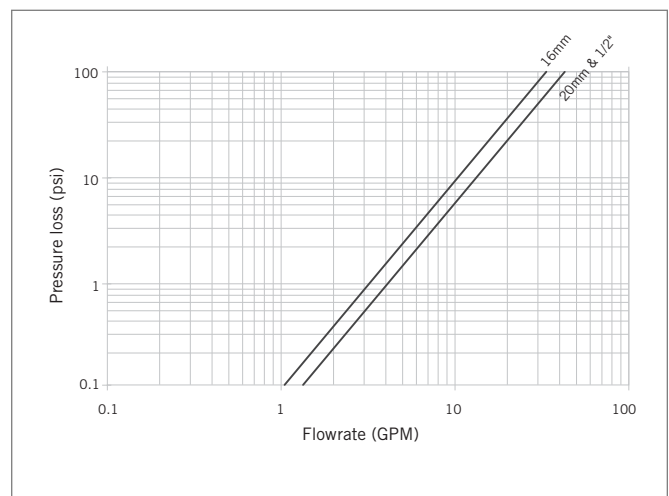

## CM SERIES COMPACT DIAPHRAGM VALVES

### Components

#### Manual Control

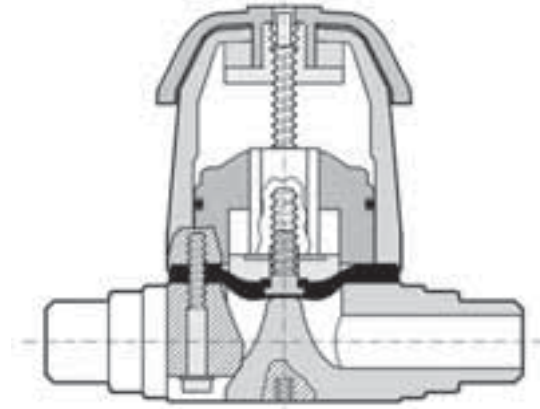
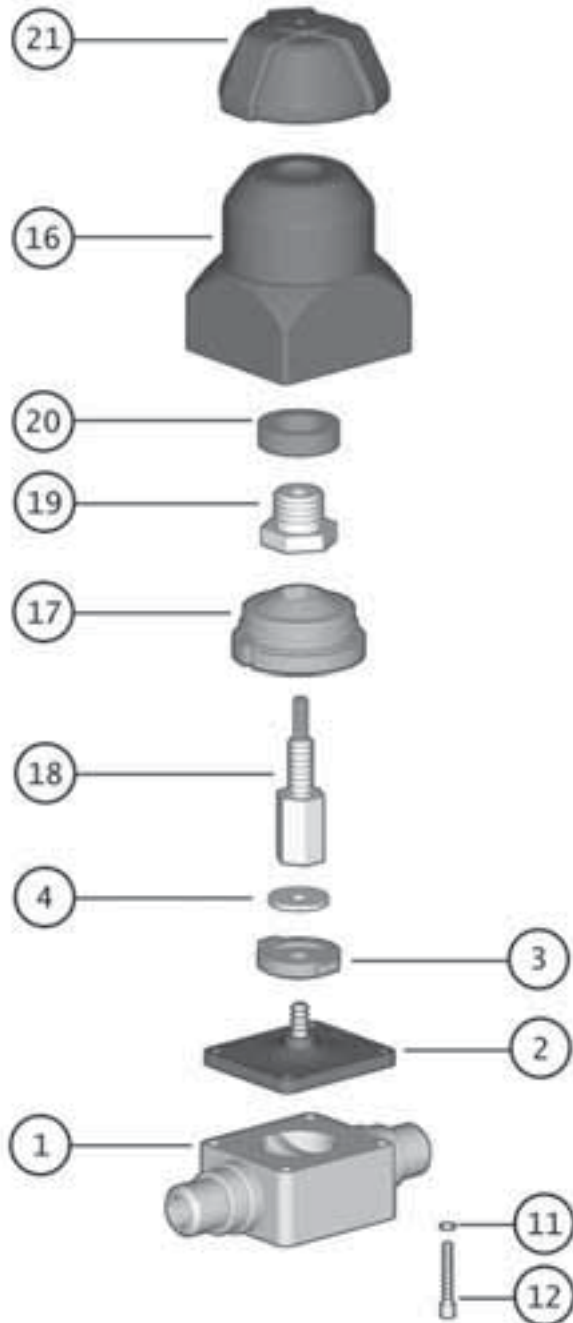

#	Component	Material	Qty
1*	valve body	PVC / CPVC / PP / PVDF	1
2	diaphragm	EPDM / Viton® / PTFE	1
3	compressor	polyamide	1
4	washer	zinc plated steel	1
11	washer	SS	4
12	bolt	zinc plated steel	4
16	cover	polyamide	1
17	guide	polyamide	1
18	indicator - stem	brass	1
19	bushing	zinc plated steel	1
20	bonnet	brass	1
21	handwheel	GRPP	1

\* Spare parts available.  
 Contact IPEX for availability of spare components for True Union style valves.

## CM SERIES COMPACT DIAPHRAGM VALVES

### Components (cont'd)

#### New Bonnet

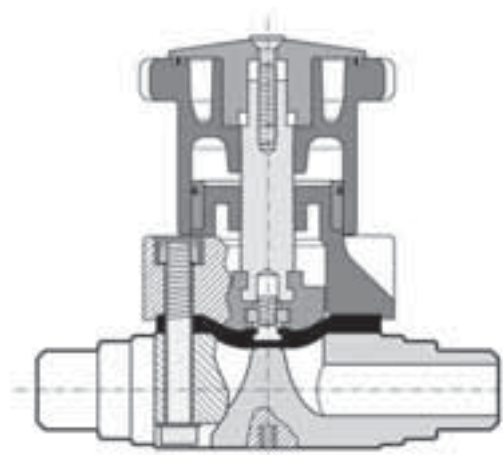
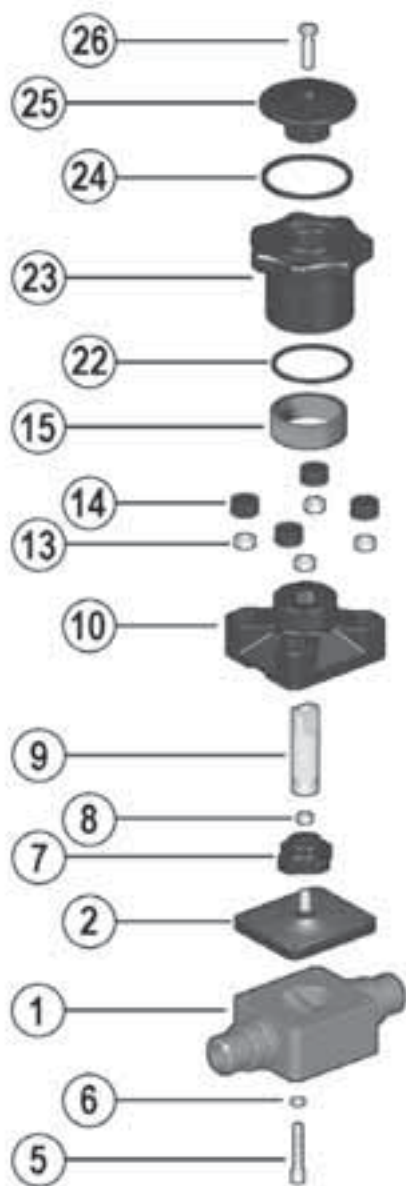

#	Component	Material	Qty
1*	valve body	PVC / CPVC / PP / PVDF	1
2	diaphragm	EPDM / Viton® / PTFE	1
5	bolt	SS	4
6	washer	SS	4
7	compressor	GRPP	1
8	nut	SS	1
9	stem	SS	1
10	bonnet	GRPP	1
13	nut	SS	4
14	protective cap	POM	4
15	position indicator	PVDF	1
22	o-ring	NBR	1
23	handwheel	GRPP	1
24	o-ring	NBR	1
25	handwheel plate	GRPP	1
26	bolt	SS	1

\* Spare parts available.

Contact IPEX for availability of spare components for True Union style valves.

## CM SERIES COMPACT DIAPHRAGM VALVES

### Components (cont'd)

#### Pneumatic Control

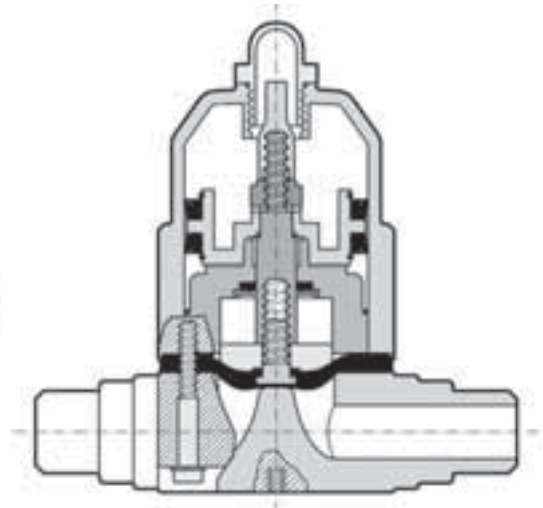
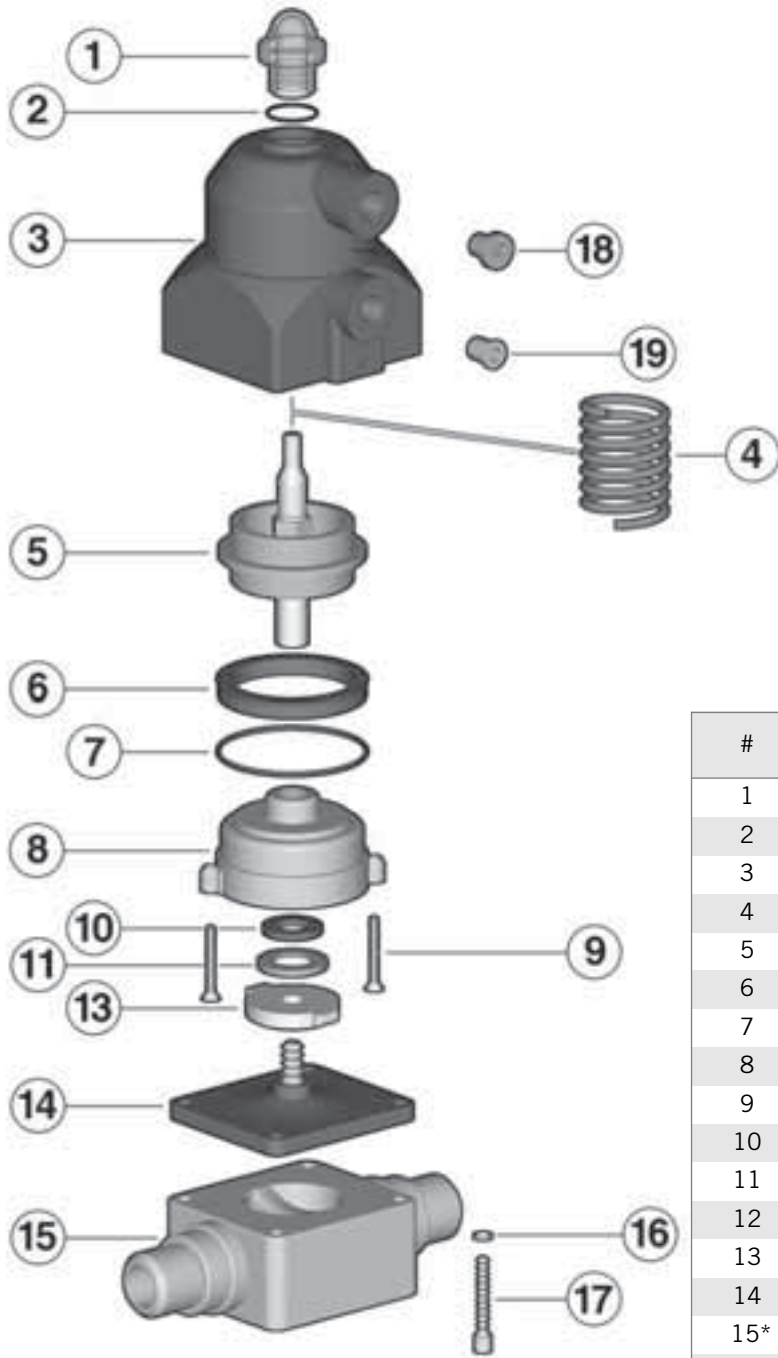

#	Component	Material	Qty
1	protective cap	PVC	1
2	o-ring	NBR	1
3	cover	polyamide	1
4	spring <sup>1</sup>	steel	1
5	stem - piston	SS - polyamide	1
6	gasket <sup>2</sup>	NBR	1
7	o-ring	NBR	1
8	guide	polyamide	1
9	bolt	zinc plated steel	2
10	gasket	NBR	1
11	washer	zinc plated steel	1
12	washer	zinc plated steel	1
13	compressor	polyamide	1
14	diaphragm	EPDM / Viton® / PTFE	1
15*	valve body	PVC / CPVC / PP / PVDF	1
16	washer	zinc plate steel	4
17	bolt	SS	4

\* Spare parts available.

Contact IPEX for availability of spare components for True Union style valves.

<sup>1</sup> for NC and NO versions only.

<sup>2</sup> o-ring for DA version.

## CM SERIES COMPACT DIAPHRAGM VALVES

### Installation Procedures

1. The valve may be installed in any position or direction.
2. Please refer to the appropriate connection style subsection:
  - a. For true union style, remove the union nuts and slide them onto the pipe.
    - i. For socket style, solvent cement the end connectors onto the pipe ends. For correct joining procedure, please refer to the section entitled, *“Joining Methods – Solvent Cementing”* in the IPEX Industrial Technical Manual Series, *“Volume 1: Vinyl Process Piping Systems”*. Ensure that excess solvent does not run into the body of the valve. **Be sure to allow sufficient cure time before continuing with the valve installation.**
    - ii. For threaded style, thread the end connectors onto the pipe ends. For correct joining procedure, please refer to the section entitled, *“Joining Methods – Threading”* in the IPEX Industrial Technical Manual Series, *“Volume 1: Vinyl Process Piping Systems”*.
    - iii. Ensure that the socket o-rings are properly fitted in their grooves then carefully place the valve in the system between the two end connections.
    - iv. Tighten both union nuts. Hand tightening is typically sufficient to maintain a seal for the maximum working pressure. Over-tightening may damage the threads on the valve body and/or the union nut, and may even cause the union nut to crack.
  - b. For socket style, solvent cement the pipe into the end connections of the valve. For correct joining procedure, please refer to the section entitled, *“Joining Methods – Solvent Cementing”* in the IPEX Industrial Technical Manual Series, *“Volume 1: Vinyl Process Piping Systems”*. Ensure that excess solvent does not run into the body of the valve. **Be sure to allow sufficient cure time before continuing with the valve installation.**
  - c. For spigot style, solvent cement each pipe onto the ends of the valve body. Ensure that excess solvent does not run into the body of the valve.
3. If anchoring is required, fix the valve to the supporting structure using the mounting holes on the bottom of the valve body (part #1 on previous page).

## CM SERIES COMPACT DIAPHRAGM VALVES

### Valve Maintenance

#### Disassembly

1. If removing the valve from an operating system, isolate the valve from the rest of the line. **Be sure to depressurize and drain the valve and isolated branch.**
2. If necessary, detach the valve from the support structure by disassembling the threaded connections on the bottom of the valve body (1).
3. Please refer to the appropriate connection style sub-section:
  - a. For true union connections, loosen both union nuts and drop the valve out of the line. If retaining the socket o-rings, take care that they are not lost when removing the valve from the line.
  - b. For socket style, cut the pipe on either side of the valve and remove from the line.
  - c. For spigot style, cut the pipe on either side of the valve and remove from the line.
4. Loosen and remove the bolts (12 or 5) and washers (11 or 6) from the bottom of the valve body. Removal of protective caps (14) is necessary to access the nuts (13) on the manual version.
5. Loosen and remove the diaphragm (2) from the compressor assembly (3 or 7, 8, 9).
6. Rotate the handwheel (21 or 23) clockwise until the stem-compressor assembly is released.
7. The valve components can now be checked for problems and/or replaced.

**Note:** It is not recommended to attempt to further disassemble the handwheel/bonnet assembly as it may cause irreversible damage to the components.

#### Assembly

**Note:** Before assembling the valve components, it is advisable to lubricate the o-rings with a water soluble lubricant. **Be sure to consult the “IPEX Chemical Resistance Guide” and/or other trusted resources to determine specific lubricant-rubber compatibilities.**

1. Insert the stem-compressor assembly (3 or 7, 8, 9) into the bonnet (20 or 10) and tighten by threading in a counterclockwise (left-hand thread) direction. Ensure that the guide tabs on the bonnet line up with the compressor grooves before cycling the handwheel (21 or 23) to further retract the compressor.
2. Insert the diaphragm (2) into the compressor and turn in a clockwise direction until sufficiently tight. Ensure that the tab lines up with the notched side of the bonnet then cycle the handwheel counterclockwise until the diaphragm is fully retracted.
3. Place the bonnet and diaphragm onto the valve body (1) taking care to properly line up the sealing surfaces.
4. Insert the bolts (12 or 5) and washers (11 or 6) and tighten in an even (cross-like) pattern.
5. For the manual version, replace the protective caps (14) on the nuts.

## DM SERIES DIAPHRAGM VALVES

IPEX DM Series Diaphragm Valves are ultra-compact, direct acting pneumatic valves. The direct operation of the diaphragm does not require a closing spring, which makes the small DM particularly suitable when space is at a premium. A rugged construction allows for use with even extremely aggressive media. DM Series Diaphragm Valves are part of our complete Xirtec®140 systems of pipe, valves, and fittings, engineered and manufactured to our strict quality, performance, and dimensional standards.



ASTM D1784  
ASTM D1785  
ASTM D2464  
ASTM D2466  
ASTM D2467  
ASTM F1498



ANSI B1.20.1  
ANSI B16.5

### Valve Availability

Body Material:	PVC
Size Range:	1/2" through 2"
Pressure:	120psi
Diaphragm:	EPDM, Viton® (FPM)
Control Style:	Pneumatically Actuated
End Connections:	Spigot True Union Flanged (ANSI 150)



## DM SERIES DIAPHRAGM VALVES

### Sample Specification

#### 1.0 Diaphragm Valves - DM

##### 1.1 Material

- The valve body, including end connectors and unions shall be made of PVC compound which shall meet or exceed the requirements of cell classification 12454 according to ASTM D1784.
- The valve bonnet assembly shall be made of glass reinforced polypropylene (GRPP).

##### 1.2 Diaphragm and O-rings

- The diaphragm shall be made of EPDM.
- or The diaphragm shall be made of Viton® (FPM).

- ##### 1.3 All wetted parts of the valves shall comply with standards that are equivalent to NSF Standard 61 for potable water.

#### 2.0 Connections

##### 2.1 Spigot style

- The IPS spigot PVC end connectors shall conform to the dimensional standard ASTM D1785.

##### 2.2 Socket style

- The IPS socket PVC end connectors shall conform to the dimensional standards ASTM D2466 and ASTM D2467.

##### 2.3 Threaded style

- The IPS threaded PVC end connectors shall conform to the dimensional standards ASTM D2464, ASTM F1498, and ANSI B1.20.1.

##### 2.4 Flanged style

- The ANSI 150 flanged PVC end connectors shall conform to the dimensional standard ANSI B16.5.

#### 3.0 Design Features

- All valves shall be weir-style for throttling applications.
- All bodies to be used with EPDM or Viton® diaphragms shall feature raised molded sealing rings (concentric).
- All through bolts shall be made of 304 stainless steel.
- Bolts will thread directly into integrally molded brass inserts in the bonnet.
- Bodies of all sizes and materials shall have mounting brass inserts.

#### 3.1 Actuators

- All actuators shall be made of glass-filled polypropylene.
- All actuators shall feature a smooth top (no nut holes) for cleanliness.
- The edge of the actuator membrane shall be inside of the actuator protective housing.

#### 3.2 Pressure Rating

- All valves shall be rated at 120psi at 73°F (23°C).

#### 3.3 Markings

- All valves shall be marked to indicate size, material designation, and manufacturers name or trade mark.

#### 3.4 Color Coding

- All PVC valves shall be color-coded dark gray.

- #### 4.0 All valves shall be Xirtec® 140 by IPEX or approved equal.

## DM SERIES DIAPHRAGM VALVES

### Dimensions

#### Spigot Connections

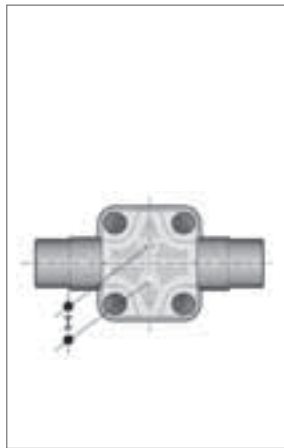
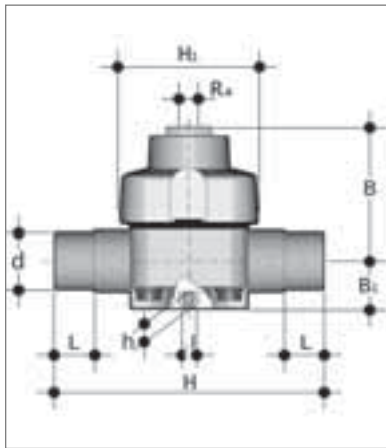

Dimension (inches)					
Size	d	H	L	B1	B
1/2	0.84	4.88	0.63	1.02	2.60
3/4	1.05	5.67	0.75	1.02	2.60
1	1.32	6.06	0.87	1.02	2.60
1-1/4	1.66	6.85	1.02	1.57	3.70
1-1/2	1.90	7.64	1.22	1.57	3.70
2	2.38	8.82	1.50	1.57	4.45

Dimension (inches)					
Size	H1	J	h	l	Ra
1/2	2.99	M6	0.47	0.98	1/4
3/4	2.99	M6	0.47	0.98	1/4
1	2.99	M6	0.47	0.98	1/4
1-1/4	3.94	M8	0.71	1.75	1/4
1-1/2	3.94	M8	0.71	1.75	1/4
2	4.53	M8	0.71	1.75	1/4

#### True Union Connections

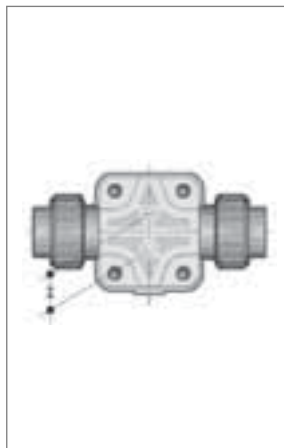
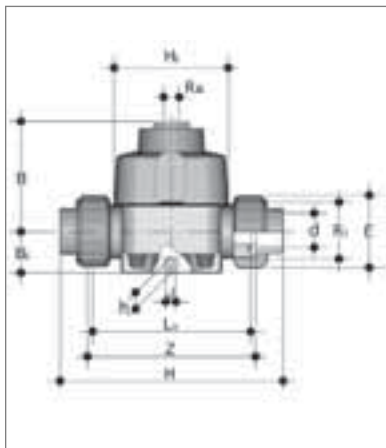

Dimension (inches)						
Size	d	H	Z	LA	R1	E
1/2	0.84	5.79	4.53	4.25	1	1.61
3/4	1.05	6.06	4.57	4.25	1-1/4	1.97
1	1.32	6.61	4.88	4.57	1-1/2	2.28
1-1/4	1.66	7.56	5.51	5.28	2	2.83
1-1/2	1.90	8.74	6.30	6.06	2-1/4	3.11
2	2.38	10.47	7.48	7.24	2-3/4	3.86

Dimension (inches)							
Size	B1	B	H1	J	h	l	Ra
1/2	1.02	2.60	2.99	M6	0.47	0.98	1/4
3/4	1.02	2.60	2.99	M6	0.47	0.98	1/4
1	1.02	2.60	2.99	M6	0.47	0.98	1/4
1-1/4	1.57	3.70	3.94	M8	0.63	1.75	1/4
1-1/2	1.57	3.70	3.94	M8	0.63	1.75	1/4
2	1.57	4.45	4.53	M8	0.63	1.75	1/4

#### Flanged Connections

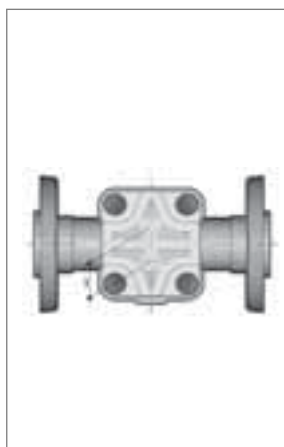
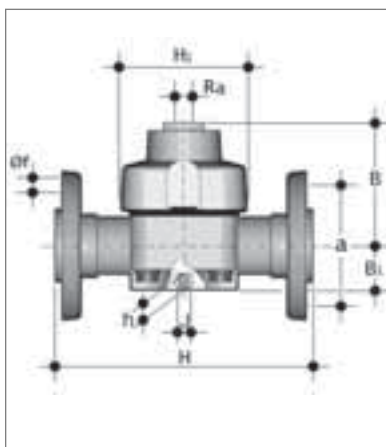

Dimension (inches)					
Size	H	B1	B	H1	Ra
1/2	5.37	1.02	2.60	2.99	1/4
3/4	6.11	1.02	2.60	2.99	1/4
1	6.58	1.02	2.60	2.99	1/4
1-1/4	7.30	1.57	3.70	3.94	1/4
1-1/2	8.02	1.57	3.70	3.94	1/4
2	8.88	1.57	4.45	4.53	1/4

Dimension (inches)						
Size	# holes	f	a	J	h	l
1/2	4	5/8	2-3/8	M6	0.47	0.98
3/4	4	5/8	2-3/4	M6	0.47	0.98
1	4	5/8	3-1/8	M6	0.47	0.98
1-1/4	4	5/8	3-1/2	M8	0.71	1.75
1-1/2	4	5/8	3-7/8	M8	0.71	1.75
2	4	3/4	4-3/4	M8	0.71	1.75

## DM SERIES DIAPHRAGM VALVES

### Dimensions - w/ Stroke Limiter & Position Indicator

#### Spigot Connections

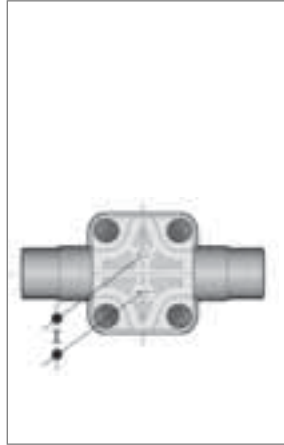
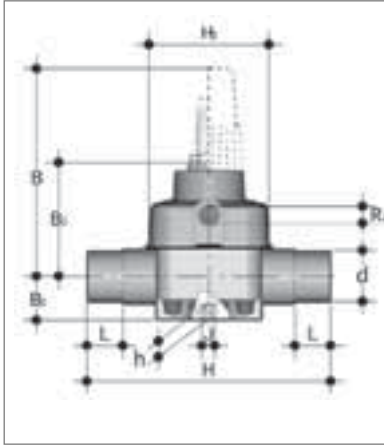

Dimension (inches)						
Size	d	H	L	B1	B	B2
1/2	0.84	4.88	0.63	1.02	5.08	2.60
3/4	1.05	5.67	0.75	1.02	5.08	2.60
1	1.32	6.06	0.87	1.02	5.08	2.60
1-1/4	1.66	6.85	1.02	1.57	7.01	3.70
1-1/2	1.90	7.64	1.22	1.57	7.01	3.70
2	2.38	8.82	1.50	1.57	8.82	4.45

Dimension (inches)					
Size	H <sub>1</sub>	J	h	l	R <sub>a</sub>
1/2	2.99	M6	0.47	0.98	1/4
3/4	2.99	M6	0.47	0.98	1/4
1	2.99	M6	0.47	0.98	1/4
1-1/4	3.94	M8	0.71	1.75	1/4
1-1/2	3.94	M8	0.71	1.75	1/4
2	4.53	M8	0.71	1.75	1/4

#### True Union Connections

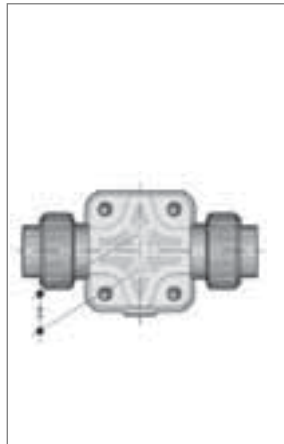
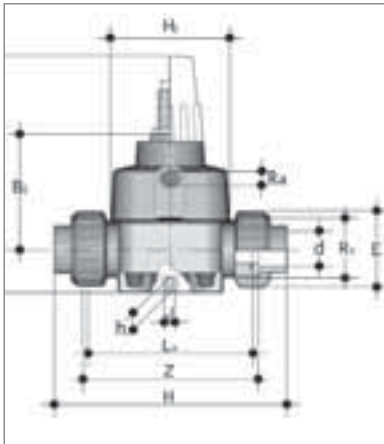

Dimension (inches)							
Size	d	H	Z	LA	R1	E	B1
1/2	0.84	5.79	4.53	4.25	1	1.61	1.02
3/4	1.05	6.06	4.57	4.25	1-1/4	1.97	1.02
1	1.32	6.61	4.88	4.57	1-1/2	2.28	1.02
1-1/4	1.66	7.56	5.51	5.28	2	2.83	1.57
1-1/2	1.90	8.74	6.30	6.06	2-1/4	3.11	1.57
2	2.38	10.47	7.48	7.24	2-3/4	3.86	1.57

Dimension (inches)							
Size	B	B2	H1	J	h	l	R <sub>a</sub>
1/2	5.08	2.60	2.99	M6	0.47	0.98	1/4
3/4	5.08	2.60	2.99	M6	0.47	0.98	1/4
1	5.08	2.60	2.99	M6	0.47	0.98	1/4
1-1/4	7.01	3.70	3.94	M8	0.63	1.75	1/4
1-1/2	7.01	3.70	3.94	M8	0.63	1.75	1/4
2	8.82	4.45	4.53	M8	0.63	1.75	1/4

#### Flanged Connections

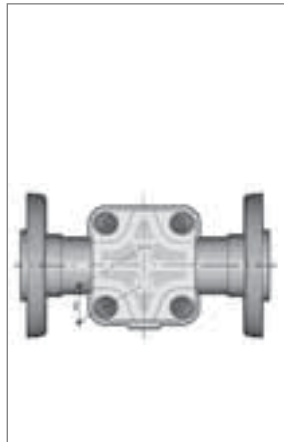
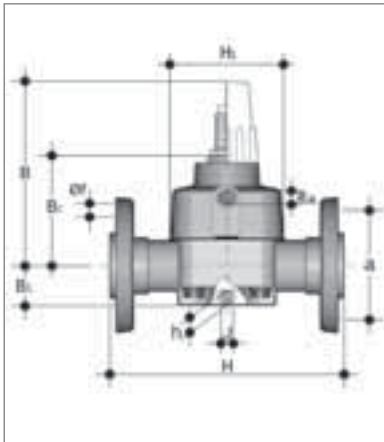

Dimension (inches)						
Size	H	B1	B	B2	H1	R <sub>a</sub>
1/2	5.37	1.02	5.08	2.60	2.99	1/4
3/4	6.11	1.02	5.08	2.60	2.99	1/4
1	6.58	1.02	5.08	2.60	2.99	1/4
1-1/4	7.30	1.57	7.01	3.70	3.94	1/4
1-1/2	8.02	1.57	7.01	3.70	3.94	1/4
2	8.88	1.57	8.82	4.45	4.53	1/4

Dimension (inches)						
Size	# holes	f	a	J	h	l
1/2	4	5/8	2-3/8	M6	0.47	0.98
3/4	4	5/8	2-3/4	M6	0.47	0.98
1	4	5/8	3-1/8	M6	0.47	0.98
1-1/4	4	5/8	3-1/2	M8	0.71	1.75
1-1/2	4	5/8	3-7/8	M8	0.71	1.75
2	4	3/4	4-3/4	M8	0.71	1.75

## DM SERIES DIAPHRAGM VALVES

### Weights

Size (inches)	Approximate Weight (lbs)					
	Normal			w/ Stroke Limiter & Position Indicator		
	Spigot	True Union	Flanged	Spigot	True Union	Flanged
1/2	0.99	1.10	1.37	1.20	1.32	1.58
3/4	0.99	1.10	1.51	1.20	1.32	1.72
1	0.99	1.10	1.71	1.20	1.32	1.92
1-1/4	2.20	2.43	3.12	2.78	2.98	3.70
1-1/2	2.20	2.43	3.42	2.78	2.98	4.00
2	3.53	3.75	5.55	4.25	4.52	6.27

### Pressure – Temperature Ratings

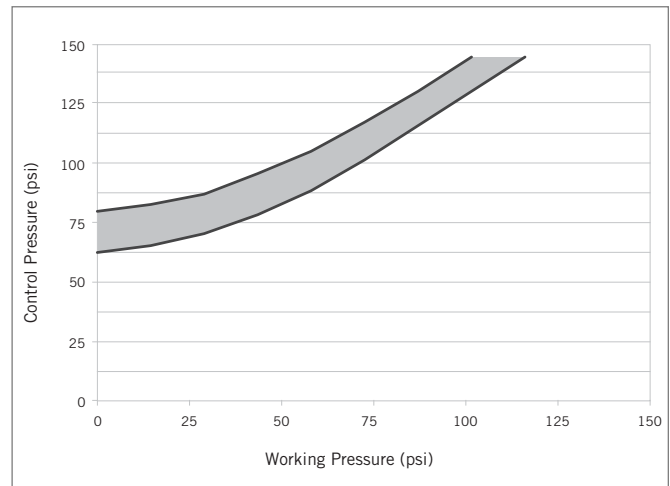
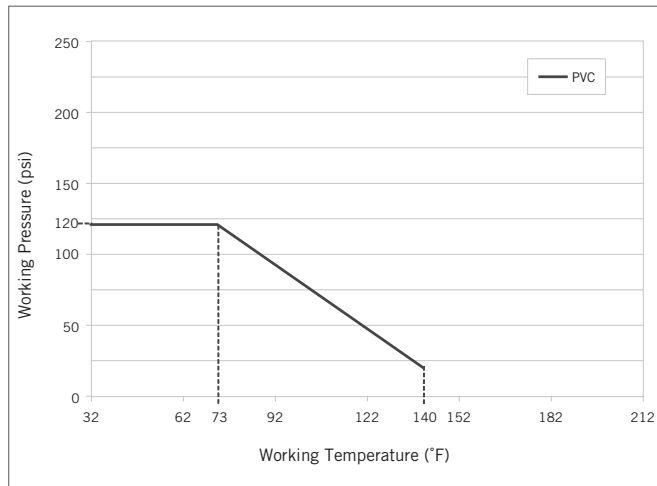

- Notes:
- The maximum working pressure is 120psi for all sizes.
  - The maximum control pressure allowed for all sizes is 145psi.
  - The control fluid temperature should not exceed 125°F (52°C).

### Flow Coefficients

Size (in)	C <sub>v</sub>
1/2	6.51
3/4	9.52
1	12.3
1-1/4	21.0
1-1/2	29.1
2	53.6

### Pressure Loss Chart

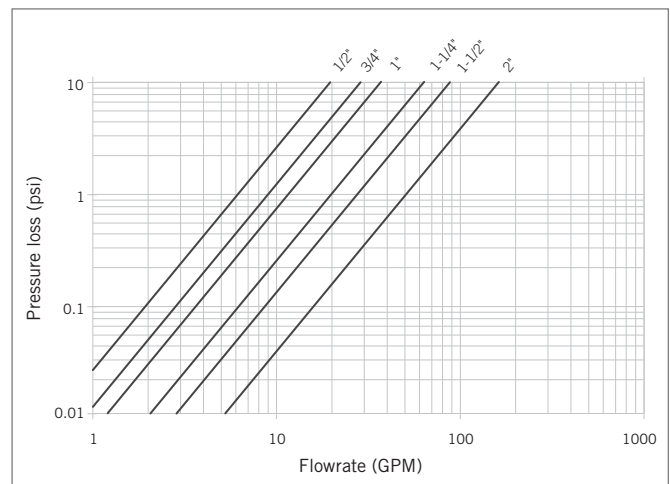

## DM SERIES DIAPHRAGM VALVES

### Components

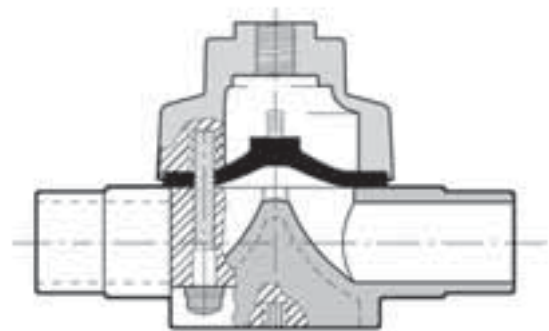
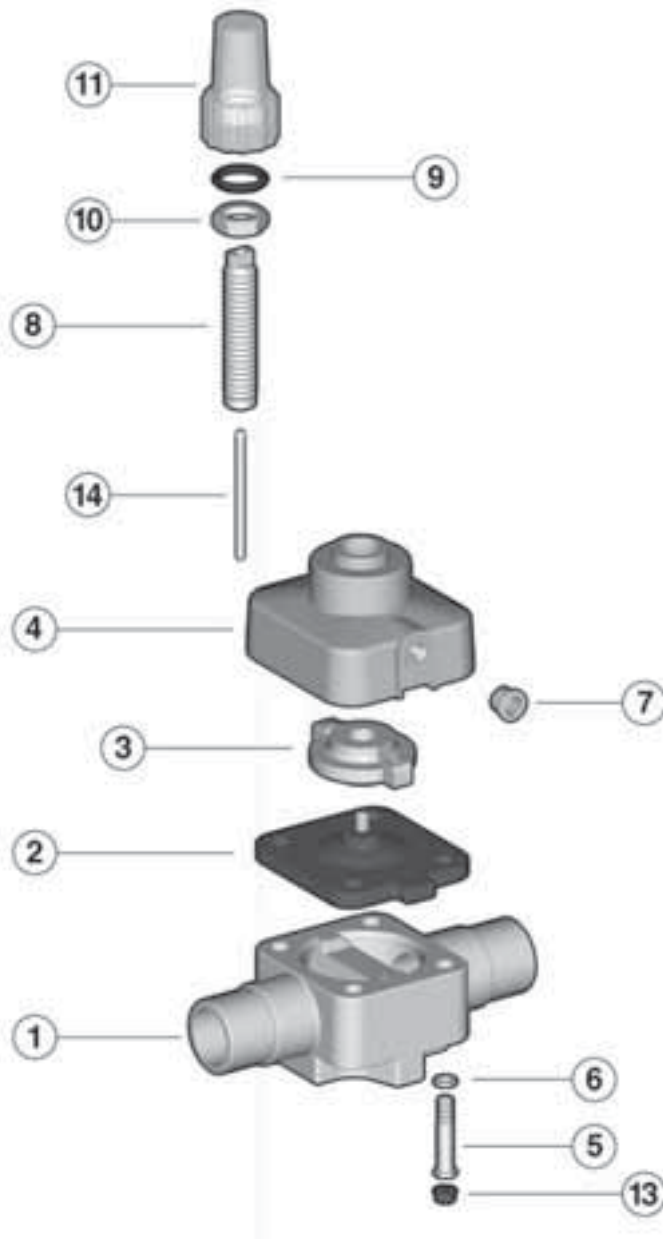

#	Component	Material	Qty
1*	valve body	PVC	1
2	diaphragm	EPDM / Viton®	1
3	compressor <sup>1</sup>	PBT	1
4	bonnet	GRPP	1
5	bolt	zinc plated steel	4
6	washer	zinc plated steel	4
7	plug <sup>1</sup>	PE	1
8	stroke limiter <sup>1</sup>	AL	1
9	o-ring <sup>1</sup>	NBR	1
10	nut <sup>1</sup>	zinc plated steel	1
11	protective cap <sup>1</sup>	PVC	1
12	plug	PE	1
13	protective cap	PE	4
14	indicator – stem <sup>1</sup>	polyamide	1

<sup>1</sup> For version w/ stroke limiter and position indicator only.

## DM SERIES DIAPHRAGM VALVES

## Installation Procedures

1. The valve may be installed in any position or direction.
2. Please refer to the appropriate connection style sub-section:
  - a. For spigot style, solvent cement each pipe onto the ends of the valve body. Ensure that excess solvent does not run into the body of the valve.
  - b. For true union style, remove the union nuts and slide them onto the pipe.
    - i. For socket style, solvent cement the end connectors onto the pipe ends. For correct joining procedure, please refer to the section entitled, *“Joining Methods - Solvent Cementing”* in the IPEX Industrial Technical Manual Series, *“Volume 1: Vinyl Process Piping Systems”*. Ensure that excess solvent does not run into the body of the valve. **Be sure to allow sufficient cure time before continuing with the valve installation.**
    - ii. For threaded style, thread the end connectors onto the pipe ends. For correct joining procedure, please refer to the section entitled, *“Joining Methods - Threading”* in the IPEX Industrial Technical Manual Series, *“Volume 1: Vinyl Process Piping Systems”*.
    - iii. Ensure that the socket o-rings are properly fitted in their grooves then carefully place the valve in the system between the two end connections.
    - iv. Tighten both union nuts. Hand tightening is typically sufficient to maintain a seal for the maximum working pressure. Over-tightening may damage the threads on the valve body and/or the union nut, and may even cause the union nut to crack.
  - c. For flanged style, join both flanges to the pipe flanges. For correct joining procedure, please refer to the section entitled, *“Joining Methods - Flanging”* in the IPEX Industrial Technical Manual Series, *“Volume 1: Vinyl Process Piping Systems”*.
3. Connect a suitable air supply and pilot system to the actuator. Be sure to check that both the working and control pressure are in accordance with the specifications.
4. If anchoring is required, fix the valve to the supporting structure using the mounting holes on the bottom of the valve body.

## Valve Maintenance

## Disassembly

1. If removing the valve from an operating system, isolate the valve from the rest of the line. **Be sure to depressurize and drain the valve and isolated branch.** Depressurize and disconnect the pneumatic control line before continuing with disassembly.
2. If necessary, detach the valve from the support structure by disassembling the threaded connections on the bottom of the valve body.
3. Please refer to the appropriate connection style sub-section:
  - a. For spigot style, cut the pipe on either side of the valve and remove from the line.
  - b. For true union connections, loosen both union nuts and drop the valve out of the line. If retaining the socket o-rings, take care that they are not lost when removing the valve from the line.
  - c. For flanged style, loosen each bolt holding the valve to the pipe flanges. Please refer to the section entitled, *“Joining Methods - Flanging”* in the IPEX Industrial Technical Manual Series, *“Volume 1: Vinyl Process Piping Systems”* for a recommended bolt tightening pattern diagram. Follow the same pattern when disassembling the flanged joints then carefully remove the valve from the line.
4. Remove the protective caps then loosen and remove the bolts and washers from the bottom of the valve body.
5. Remove the diaphragm from the valve body.
6. If applicable, loosen and remove the stroke limiter and position indicator
7. The valve components can now be checked for problems and/or replaced.

## Assembly

**Note:** Before assembling the valve components, it is advisable to lubricate the o-rings with a water soluble lubricant. **Be sure to consult the “IPEX Chemical Resistance Guide” and/or other trusted resources to determine specific lubricant-rubber compatibilities.**

1. Position the diaphragm on the bonnet.
2. Place the bonnet and diaphragm onto the valve body taking care to properly line up the sealing surfaces.
3. Insert the bolts and washers and tighten in an even (cross-like) pattern.
4. Replace the protective caps.
5. If applicable, replace the stroke limiter, position indicator, and o-ring.

## SECTION FIVE: CHECK AND VENT VALVES

### VB SERIES BALL CHECK VALVES

IPEX VB Ball Check Valves are a simple solution for smaller diameter plastic piping systems. This popular style of check valve features a true union design allowing for easy removal and maintenance. Full length guide ribs allow for maximum flow and minimum turbulence, preventing ball sticking and chatter. Just a few psi of back pressure is needed for positive shut off in both vertical and horizontal orientations. VB Ball Check Valves are part of our complete Xirtec®140 and Corzan® systems of pipe, valves, and fittings, engineered and manufactured to our strict quality, performance, and dimensional standards.

#### Valve Availability

Body Material:	PVC, CPVC
Size Range:	1/2" through 4"
Pressure:	150psi
Seals:	EPDM, Viton® (FPM)
End Connections:	Socket (IPS) Threaded (FNPT) Flanged (ANSI 150)



ASTM D1784  
ASTM D2464  
ASTM D2466  
ASTM D2467  
ASTM F1498  
ASTM F437  
ASTM F439



ANSI B1.20.1  
ANSI B16.5



## VB SERIES BALL CHECK VALVES

### Sample Specification

#### 1.0 Check Valves - VB

##### 1.1 Material

- The valve body, ball, end connectors, and unions shall be made of PVC compound which shall meet or exceed the requirements of cell classification 12454 according to ASTM D1784.
- or The valve body, ball, end connectors, and unions shall be made of Corzan® CPVC compound which shall meet or exceed the requirements of cell classification 23447 according to ASTM D1784.

##### 1.2 Seals

- The o-ring seals shall be made of EPDM.
- or The o-ring seals shall be made of Viton® (FPM).

**1.3** All wetted parts of the valves shall comply with standards that are equivalent to NSF Standard 61 for potable water.

#### 2.0 Connections

##### 2.1 Socket style

- The IPS socket PVC end connectors shall conform to the dimensional standards ASTM D2466 and ASTM D2467.
- or The IPS socket CPVC end connectors shall conform to the dimensional standard ASTM F439.

##### 2.2 Threaded style

- The female NPT threaded PVC end connectors shall conform to the dimensional standards ASTM D2464, ASTM F1498, and ANSI B1.20.1.
- or The female NPT threaded CPVC end connectors shall conform to the dimensional standards ASTM F437, ASTM F1498, and ANSI B1.20.1.

##### 2.3 Flanged style

- The ANSI 150 flanged PVC end connectors shall conform to the dimensional standard ANSI B16.5.
- or The ANSI 150 flanged CPVC end connectors shall conform to the dimensional standard ANSI B16.5.

#### 3.0 Design Features

- The valve shall have true union ends.
- The valve cavity shall feature full body guide ribs for increased flow.
- The valve body and union nuts shall have deep square style threads for increased strength.

##### 3.1 Pressure Rating

- All valves shall be rated at 150psi at 73°F (23°C).

##### 3.2 Markings

- All valves shall be marked to indicate size, material designation, and manufacturers name or trade mark.

##### 3.3 Color Coding

- All PVC valves shall be color-coded dark gray.
- or All CPVC valves shall be color-coded light gray.

**4.0** All valves shall be Xirtec® 140 or Corzan® by IPEX or approved equal.

## VB SERIES BALL CHECK VALVES

### Dimensions

Size	Dimension (inches)									
	D1	Socket	d Threaded	H	L	B	L	Flanged		Bolt hole CTR-CTR
								# holes	Bolt dia	
1/2	0.60	0.84	1/2 NPT	0.89	3.98	2.11	5.79	4	5/8	2-3/8
3/4	0.77	1.05	3/4 NPT	1.00	4.53	2.49	6.47	4	5/8	2-3/4
1	0.98	1.32	1 NPT	1.13	5.35	2.88	7.48	4	5/8	3-1/8
1-1/4	1.26	1.66	1-1/4 NPT	1.26	6.73	3.84	8.92	4	5/8	3-1/2
1-1/2	1.57	1.90	1-1/2 NPT	1.38	6.73	3.84	9.23	4	5/8	3-7/8
2	1.97	2.38	2 NPT	1.50	7.68	4.74	10.43	4	3/4	4-3/4
2-1/2	2.56	2.88	2-1/2 NPT	1.75	8.74	6.00	11.37	4	3/4	5-1/2
3	3.15	3.50	3 NPT	1.89	10.79	7.25	13.28	4	3/4	6
4	3.94	4.50	4 NPT	2.26	14.45	8.00	17.27	8	3/4	7-1/2

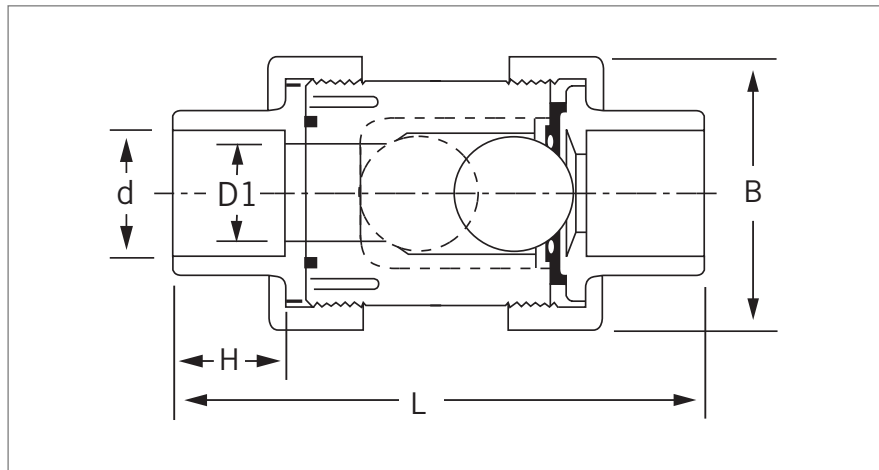

### Weights

Size	Approximate Weight (lbs)					
	IPS Socket	PVC			CPVC	
		FNPT Threaded	ANSI Flanged		IPS Socket	FNPT Threaded
1/2	0.25	0.25	0.65	0.26	0.26	0.68
3/4	0.50	0.50	1.08	0.53	0.53	1.13
1	0.96	0.96	1.74	1.01	1.01	1.83
1-1/4	2.23	2.23	3.23	2.34	2.34	3.34
1-1/2	2.53	2.53	3.73	2.66	2.66	3.92
2	3.80	3.80	5.68	3.99	3.99	5.99
2-1/2	6.88	6.88	9.46	7.22	7.22	10.31
3	12.87	12.87	16.61	13.51	13.51	17.47
4	19.00	19.00	24.99	19.95	19.95	26.28

CHECK & VENT  
VALVES

## VB SERIES BALL CHECK VALVES

### Pressure – Temperature Ratings

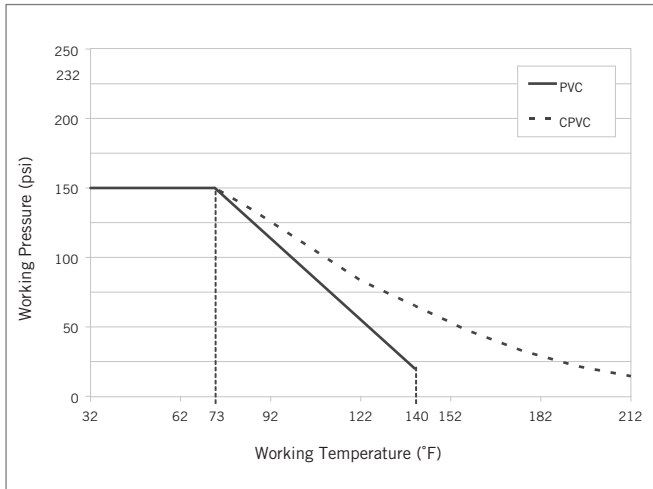

### Pressure Loss Chart

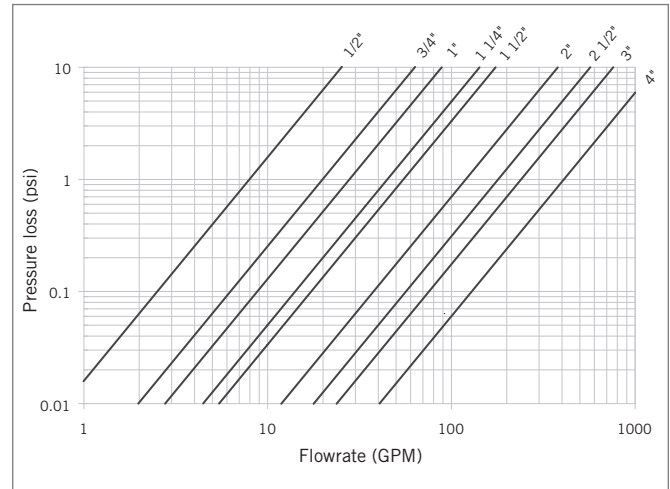

### Flow Coefficients

Size	C <sub>v</sub>
1/2	8.00
3/4	20.0
1	28.0
1-1/4	45.0
1-1/2	55.0
2	120
2-1/2	180
3	240
4	410

### Components

#	Component	Material	Qty
1	body	PVC / CPVC	1
2	ball	PVC / CPVC	1
3	seat carrier	PVC / CPVC	1
4*	end connector	PVC / CPVC	2
5*	seat	EPDM or FPM	1
6*	union nut	PVC / CPVC	2
7*	o-ring	EPDM or FPM	1

\* Spare parts available

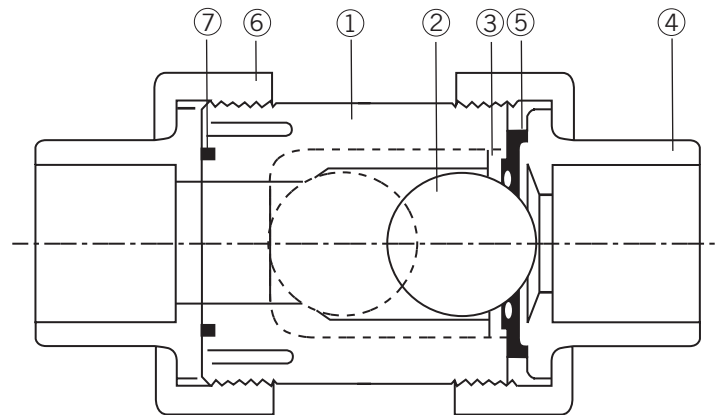

## VB SERIES BALL CHECK VALVES

### Installation Procedures

1. For socket and threaded style connections, remove the union nuts (part #6 on previous page) and slide them onto the pipe. For flanged connections, remove the union nut / flange assemblies from the valve. It is important to first check the pipe flow direction and corresponding valve orientation as the two end connectors are not the same.
2. Please refer to the appropriate connection style subsection:
  - a. For socket style, solvent cement the end connectors (4) onto the pipe ends. For correct joining procedure, please refer to the section entitled, *“Joining Methods – Solvent Cementing”* in the IPEX Industrial Technical Manual Series, *“Volume I: Vinyl Process Piping Systems”*. **Be sure to allow sufficient cure time before continuing with the valve installation.**
  - b. For threaded style, thread the end connectors (4) onto the pipe ends. For correct joining procedure, please refer to the section entitled, *“Joining Methods – Threading”* in the IPEX Industrial Technical Manual Series, *“Volume I: Vinyl Process Piping Systems”*.
  - c. For flanged style, join the union nut / flange assemblies to the pipe flanges. For correct joining procedure, please refer to the section entitled, *“Joining Methods – Flanging”* in the IPEX Industrial Technical Manual Series, *“Volume I: Vinyl Process Piping Systems”*.
3. Ensure that the valve is in the correct orientation, and that the seat (5) and o-ring (7) are properly fitted in their grooves. Carefully place the valve in the system between the two end connections.
4. Tighten both union nuts. Hand tightening is typically sufficient to maintain a seal for the maximum working pressure. Over-tightening may damage the threads on the valve body and/or the union nut, and may even cause the union nut to crack.

### Valve Maintenance

#### Disassembly

1. If removing the valve from an operating system, isolate the valve from the rest of the system. **Be sure to depressurize and drain the isolated branch and valve before continuing.**
2. Loosen both union nuts (6) and drop the valve out of the line. If retaining the seat (5) and o-ring (7), take care that they are not lost when removing the valve from the line.
3. To disassemble, remove the seat and o-ring from the ends of the valve body (1).
4. Remove the ball (2) and the seat carrier (3).
5. The valve components can now be checked for problems and/or replaced.

#### Assembly

**Note:** Before assembling the valve components, it is advisable to lubricate the o-rings with a water soluble lubricant. **Be sure to consult the “IPEX Chemical Resistance Guide” and/or other trusted resources to determine specific lubricant-rubber compatibilities.**

1. Firmly place the seat carrier (3) in the open end of the valve body (1). The grooved edge should face upwards to mate properly with the seat (5).
2. Place the ball (2) into the valve body.
3. Properly fit the o-ring (7) and the seat (5) in the grooves on either end of the valve body.
4. Place the end connectors (4) into the union nuts (6), then thread onto the valve body taking care that the o-ring and seat remain properly fitted in their grooves. Be sure to check that the proper end connector is assembled with the seat end of the valve as the two are not the same.



## VR SERIES PISTON CHECK VALVES

The IPEX VR Piston Check Valve is an ideal solution for process back-flow prevention. These valves feature all PVC high performance components allowing for increased flow rate yet a low-return pressure for positive seal. With installation possible in both horizontal and vertical orientations, the top-entry design provides for simple in-line maintenance. VR Piston Check Valves are part of our complete Xirtex®140 systems of pipe, valves, and fittings, engineered and manufactured to our strict quality, performance, and dimensional standards.

### Valve Availability

Body Material:	PVC
Size Range:	1/2" through 4"
Pressure:	232psi (1/2" to 1") 150psi (1-1/4" to 2") 90psi (3" to 4")
Seals:	EPDM, Viton® (FPM)
End Connections:	Socket (IPS) Threaded (FNPT) Flanged (ANSI 150)



ASTM D1784  
ASTM D2464  
ASTM D2466  
ASTM D2467  
ASTM F1498



ANSI B1.20.1  
ANSI B16.5



## VR SERIES PISTON CHECK VALVES

### Sample Specification

#### 1.0 Check Valves - VR

##### 1.1 Material

- The valve body, end connectors, and unions shall be made of PVC compound which shall meet or exceed the requirements of cell classification 12454 according to ASTM D1784.

##### 1.2 Seals

- The o-ring seals and shutter shall be made of EPDM.
- or
- The o-ring seals and shutter shall be made of Viton® (FPM).

- 1.3** All wetted parts of the valves shall comply with standards that are equivalent to NSF Standard 61 for potable water.

#### 2.0 Connections

##### 2.1 Socket style

- The IPS socket PVC end connectors shall conform to the dimensional standards ASTM D2466 and ASTM D2467.

##### 2.2 Threaded style

- The female NPT threaded PVC end connectors shall conform to the dimensional standards ASTM D2464, ASTM F1498, and ANSI B1.20.1.

##### 2.3 Flanged style

- The ANSI 150 flanged PVC end connectors shall conform to the dimensional standard ANSI B16.5.

#### 3.0 Design Features

- Valve sizes 1/2" through 2" shall have true union ends.
- Valve sizes 3" through 4" shall have either socket or threaded ends.
- All valves shall be y-pattern globe style in design.
- All valves shall be gravity operated.
- The weight shall be totally encapsulated inside the piston.
- The valve shall function in both horizontal and vertical lines with no minimum column requirements.
- Servicing of the valves shall be possible without removal from the line.

#### 3.1 Pressure Rating

- Valve sizes 1/2" through 1" shall be rated at 232psi at 73°F (23°C).
- Flanged valve sizes 1/2" through 1" shall be rated at 150psi at 73°F (23°C).
- Valve sizes 1-1/4" through 2" shall be rated at 150psi at 73°F (23°C).
- Valve sizes 3" through 4" shall be rated at 90psi at 73°F (23°C).

#### 3.2 Markings

- All valves shall be marked to indicate size, material designation, and manufacturers name or trade mark.

#### 3.3 Color Coding

- All PVC valves shall be color-coded dark gray.

- 4.0** All valves shall be Xirtec® 140 by IPEX or approved equal.

## VR SERIES PISTON CHECK VALVES

### Dimensions

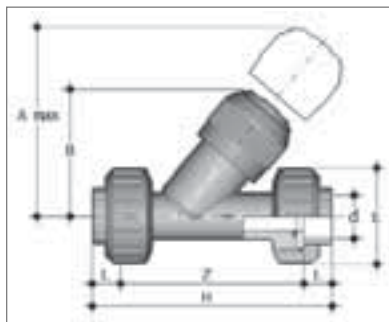

IPS Socket Connections - Dimension (inches)							
Size	d	L	Z	H	E	B	A <sub>max</sub>
1/2	0.84	0.63	4.06	5.31	2.17	2.83	4.92
3/4	1.05	0.75	4.72	6.22	2.60	3.31	5.71
1	1.32	0.87	5.20	6.93	2.95	3.74	6.50
1-1/4	1.66	1.02	6.10	8.15	3.43	4.37	7.48
1-1/2	1.90	1.22	7.13	9.57	3.94	4.72	8.27
2	2.38	1.50	8.72	11.73	4.72	5.47	9.45

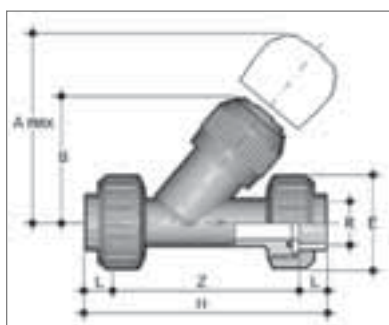

Female NPT Threaded Connections - Dimension (inches)							
Size	R	L	Z	H	E	B	A <sub>max</sub>
1/2	1/2-NPT	0.59	4.45	5.63	2.17	2.83	4.92
3/4	3/4-NPT	0.64	5.02	6.30	2.60	3.31	5.71
1	1-NPT	0.75	5.70	7.20	2.95	3.74	6.50
1-1/4	1-1/4-NPT	0.84	6.74	8.43	3.43	4.37	7.48
1-1/2	1-1/2-NPT	0.84	7.57	9.25	3.94	4.72	8.27
2	2-NPT	1.01	9.20	11.22	4.72	5.47	9.45

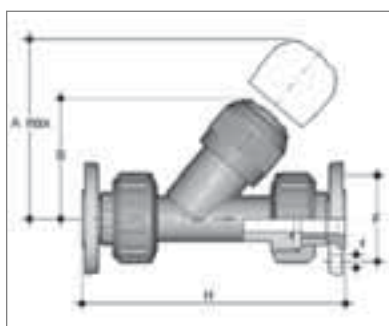

ANSI 150 Flanged (Vanstone) Connections - Dimension (inches)						
Size	# holes	f	F	H	B	A <sub>max</sub>
1/2	4	5/8	2-3/8	7.13	2.83	4.92
3/4	4	5/8	2-3/4	8.16	3.31	5.71
1	4	5/8	3-1/8	9.05	3.74	6.50
1-1/4	4	5/8	3-1/2	10.34	4.37	7.48
1-1/2	4	5/8	3-7/8	12.07	4.72	8.27
2	4	3/4	4-3/4	14.48	5.47	9.45

## VR SERIES PISTON CHECK VALVES

### Dimensions (cont'd)

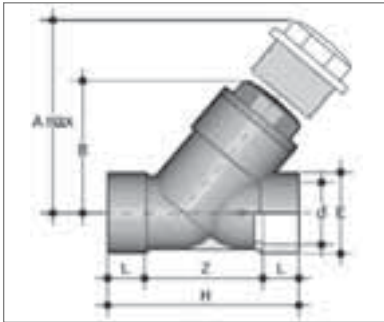

IPS Socket Connections - Dimension (inches)							
Size	R	L	Z	H	E	B	A <sub>max</sub>
3	3.50	2.01	6.30	10.31	4.57	7.56	12.80
4	4.50	2.40	7.99	12.80	5.43	9.09	15.16

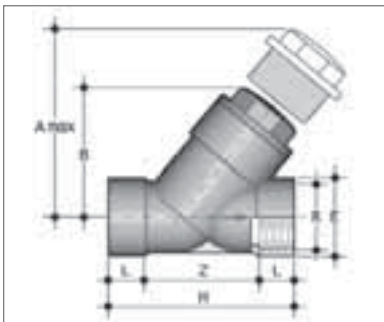

Female NPT Threaded Connections - Dimension (inches)							
Size	R	L	Z	H	E	B	A <sub>max</sub>
3	3-NPT	1.31	7.69	10.31	4.57	7.56	12.80
4	4-NPT	1.55	9.70	12.80	5.43	9.09	15.16

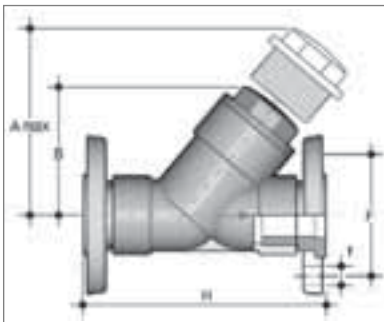

ANSI 150 Flanged (Vanstone) Connections - Dimension (inches)						
Size	# holes	f	F	H	B	A <sub>max</sub>
3	4	3/4	6	12.81	7.56	12.80
4	8	3/4	7-1/2	15.62	9.09	15.16

## VR SERIES PISTON CHECK VALVES

### Weights

Size	Approximate Weight (lbs)		
	IPS Socket	FNPT Threaded	ANSI Flanged
1/2	0.50	0.51	0.90
3/4	0.86	0.86	1.44
1	1.34	1.33	2.12
1-1/4	2.03	2.05	3.04
1-1/2	2.94	2.96	4.14
2	5.10	5.18	6.98
3	9.99	9.96	13.73
4	15.81	15.36	21.80

### Pressure – Temperature Ratings

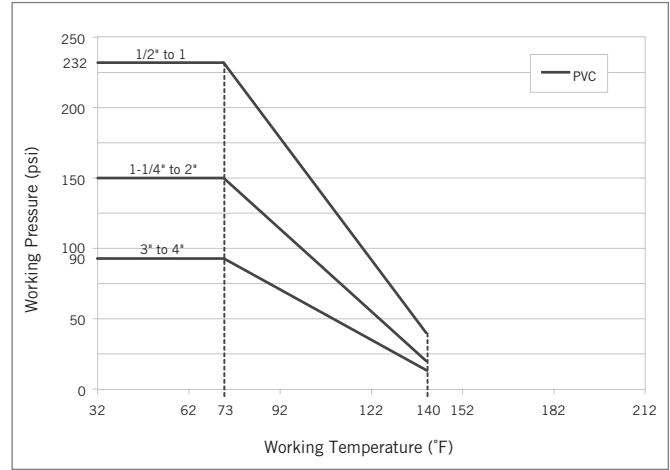

### Flow Coefficients

Size	C <sub>v</sub>
1/2	7.70
3/4	14.4
1	26.3
1-1/4	39.2
1-1/2	58.5
2	91.0
3	182
4	245

### Pressure Loss Chart

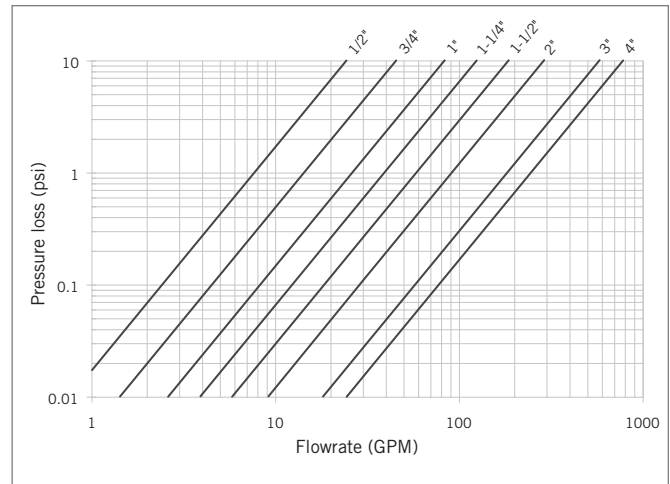

## VR SERIES PISTON CHECK VALVES

### Minimum Back Pressure to Seal

Size (inches)	P (psi)
1/2	0.21
3/4	0.28
1	0.50
1-1/4	0.50
1-1/2	0.50
2	0.50
3	0.50
4	0.50

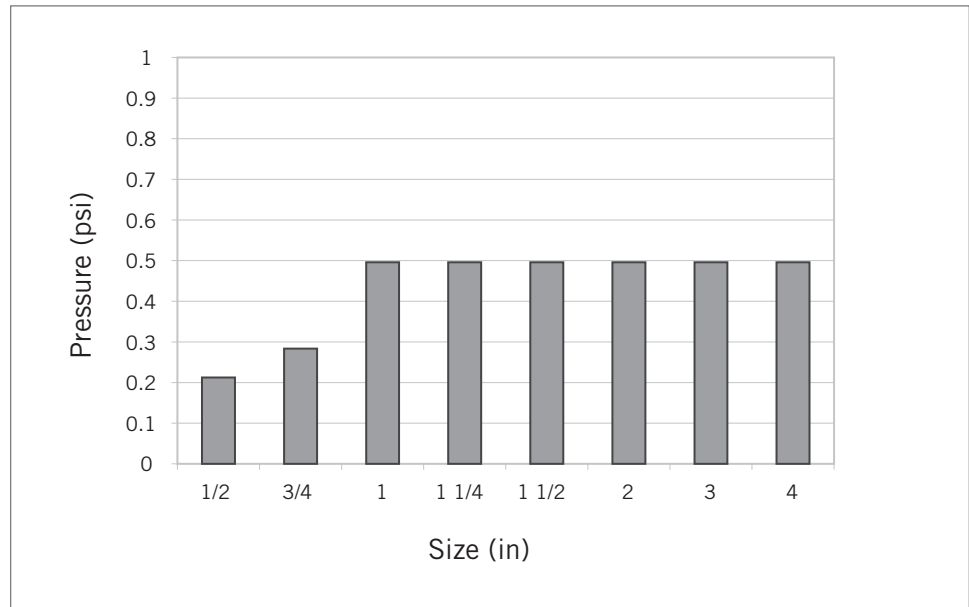

### Minimum Pressure to Open

Size (inches)	P (psi)
1/2	0.12
3/4	0.13
1	0.20
1-1/4	0.25
1-1/2	0.26
2	0.30
3	0.32
4	0.35

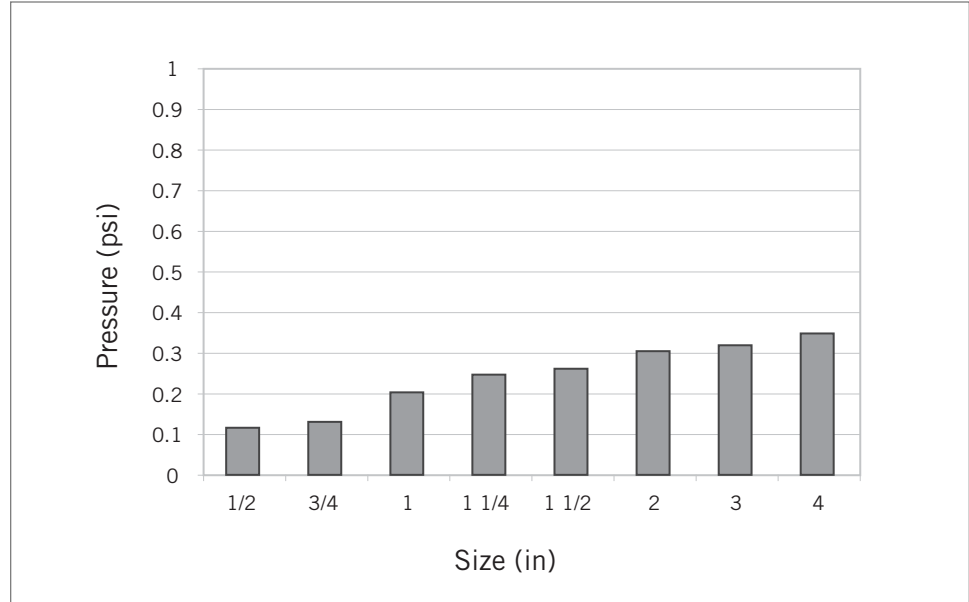

## VR SERIES PISTON CHECK VALVES

### Components

Sizes 1/2" through 2"

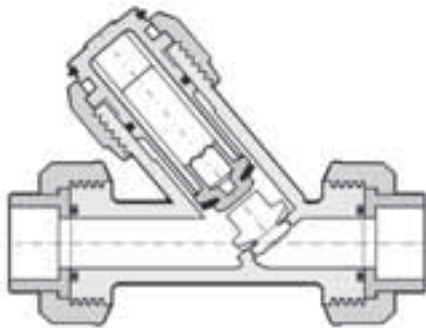
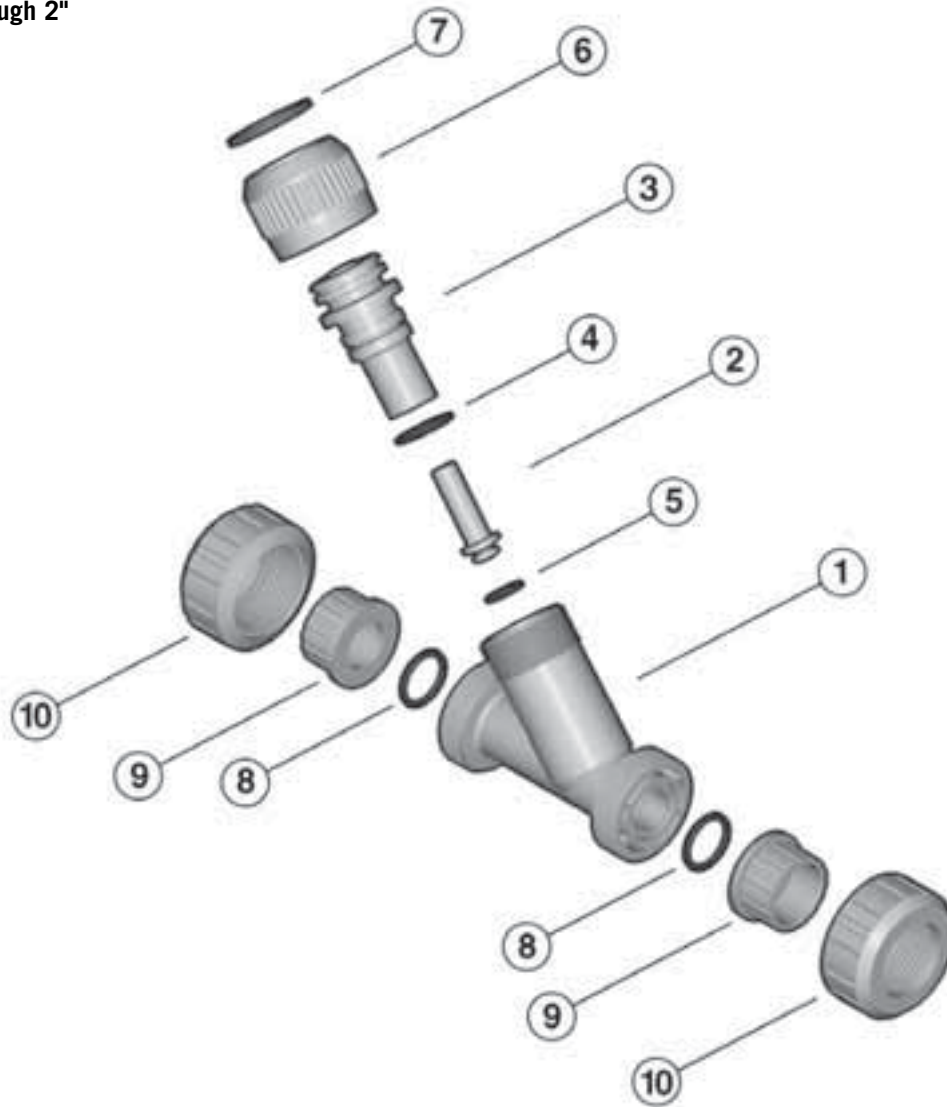

#	Component	Material	Qty
1	body	PVC	1
2	piston	PVC	1
3	bonnet	PVC	1
4	o-ring seal	EPDM or Viton®	1
5	flat gasket	EPDM or Viton®	1
6	lock nut	PVC	1
7	split ring	PVC	1
8	socket o-ring	EPDM or Viton®	2
9	end connector	PVC	2
10	union nut	PVC	2

## VR SERIES PISTON CHECK VALVES

### Components (cont'd)

Size 3"

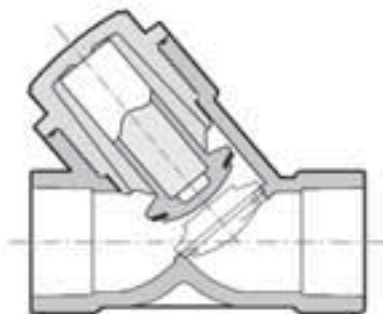
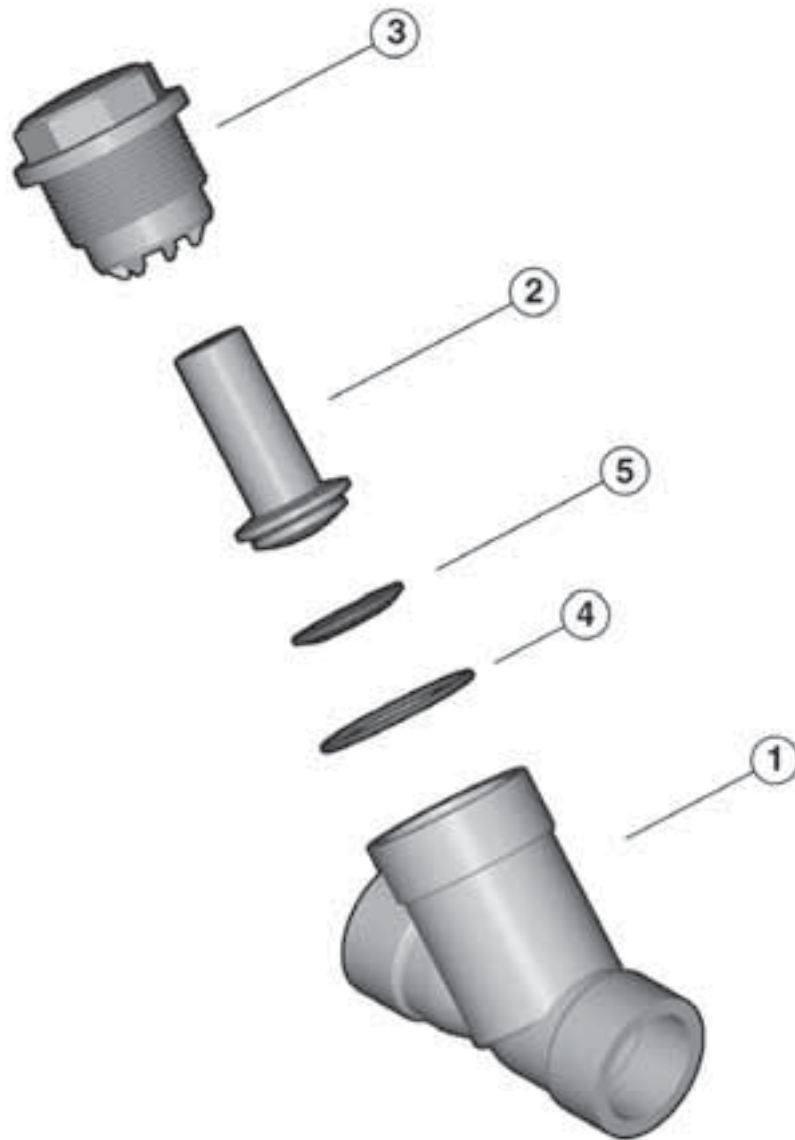

#	Component	Material	Qty
1	body	PVC	1
2	piston	PVC	1
3	bonnet	PVC	1
4	o-ring seal	EPDM or Viton®	1
5	flat gasket	EPDM or Viton®	1

## VR SERIES PISTON CHECK VALVES

Components (cont'd)

Size 4"

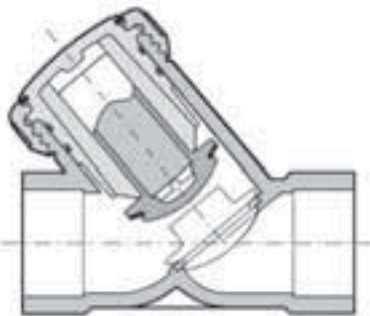
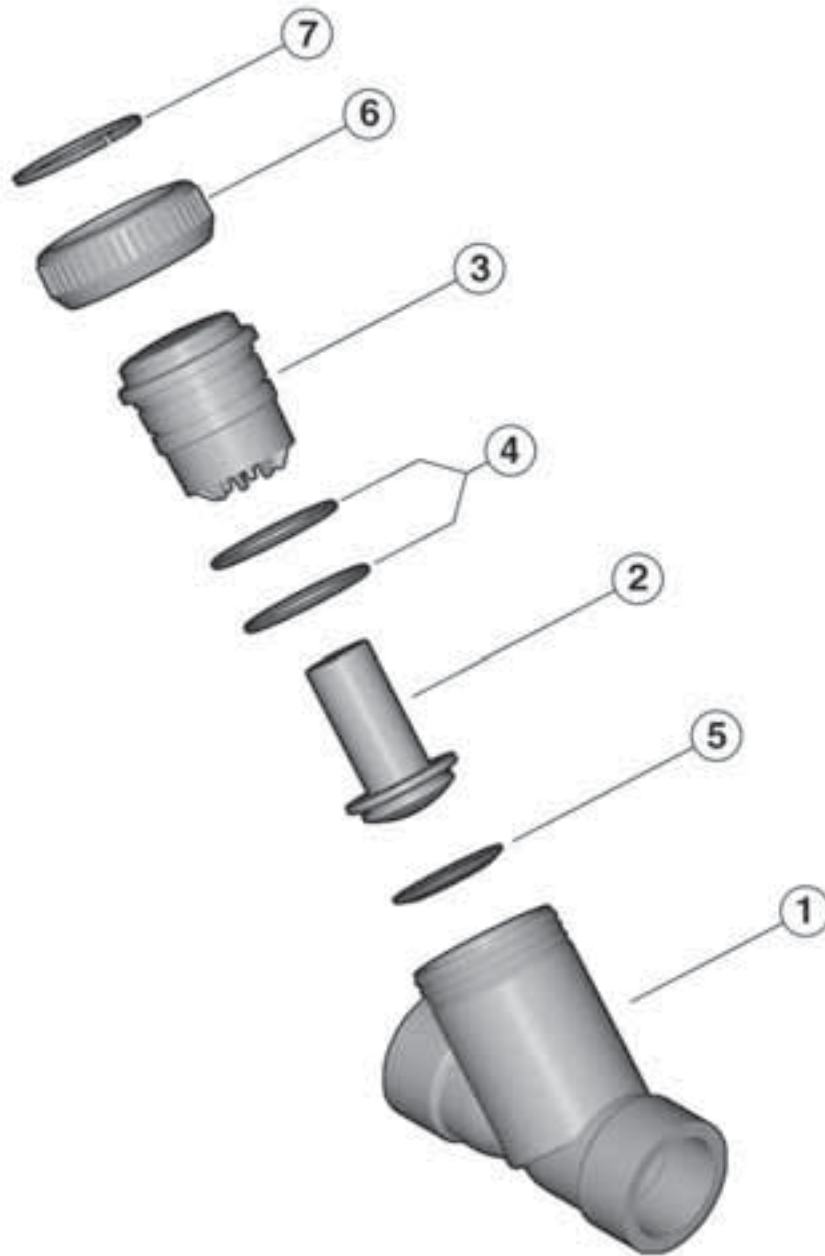

#	Component	Material	Qty
1	body	PVC	1
2	piston	PVC	1
3	bonnet	PVC	1
4	o-ring seal	EPDM or Viton®	2
5	flat gasket	EPDM or Viton®	1
6	lock nut	PVC	1
7	split ring	PVC	1

## VR SERIES PISTON CHECK VALVES

### Installation Procedures

#### True Union Style:

1. For socket and threaded style connections, remove the union nuts (part #10 on previous pages) and slide them onto the pipe. For flanged connections, remove the union nut / flange assemblies from the valve.
2. Please refer to the appropriate connection style sub-section:
  - a. For socket style, solvent cement the end connectors (9) onto the pipe ends. For correct joining procedure, please refer to the section entitled, *“Joining Methods – Solvent Cementing”* in the IPEX Industrial Technical Manual Series, *“Volume I: Vinyl Process Piping Systems”*. **Be sure to allow sufficient cure time before continuing with the valve installation.**
  - b. For threaded style, thread the end connectors (9) onto the pipe ends. For correct joining procedure, please refer to the section entitled, *“Joining Methods – Threading”* in the IPEX Industrial Technical Manual Series, *“Volume I: Vinyl Process Piping Systems”*.
  - c. For flanged style, join the union nut / flange assemblies to the pipe flanges. For correct joining procedure, please refer to the section entitled, *“Joining Methods – Flanging”* in the IPEX Industrial Technical Manual Series, *“Volume I: Vinyl Process Piping Systems”*.
3. Ensure that the valve is in the correct orientation, and that the socket o-rings (8) are properly fitted in their grooves. Carefully place the valve in the system between the two end connections.
4. Tighten both union nuts and the lock nut (6). Hand tightening is typically sufficient to maintain a seal for the maximum working pressure. Over-tightening may damage the threads on the valve body and/or the nut, and may even cause the nut to crack.

#### Non True Union Style:

1. Please refer to the appropriate connection style sub-section:
  - a. For socket style, ensure that the valve is in the correct orientation then solvent cement the end connections of the valve body (1) to the pipe ends. For correct joining procedure, please refer to the section entitled, *“Joining Methods – Solvent Cementing”* in the IPEX Industrial Technical Manual Series, *“Volume I: Vinyl Process Piping Systems”*. **Be sure to allow sufficient cure time before continuing with the valve installation.**
  - b. For threaded style, ensure that the valve is in the correct orientation then thread the pipe ends into the valve body (1). For correct joining procedure, please refer to the section entitled, *“Joining Methods – Threading”* in the IPEX Industrial Technical Manual Series, *“Volume I: Vinyl Process Piping Systems”*.
  - c. For flanged style, ensure that the valve is in the correct orientation then join to the pipe flanges. For correct joining procedure, please refer to the section entitled, *“Joining Methods – Flanging”* in the IPEX Industrial Technical Manual Series, *“Volume I: Vinyl Process Piping Systems”*.
2. Ensure that the bonnet (3, size 3") or lock nut (6, size 4") is sufficiently tightened. Hand tightening is typically sufficient to maintain a seal for the maximum working pressure. Over-tightening may damage the threads on the valve body and/or the nut, and may even cause the nut to crack.

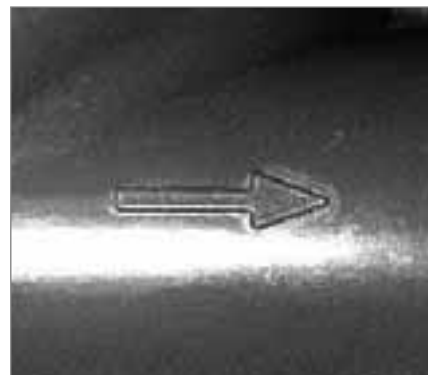

## VR SERIES PISTON CHECK VALVES

### Valve Maintenance

#### Disassembly

1. If removing the valve from an operating system, isolate the valve from the rest of the system. **Be sure to depressurize and drain the isolated branch and valve before continuing.**
2. For true union style, loosen both union nuts (10) and drop the valve out of the line. If retaining the socket o-rings (8), take care that they are not lost when removing the valve from the line.
3. For sizes 1/2" through 2" and 4":
  - a. Loosen the lock nut (6) – bonnet (3) assembly and remove from the valve body (1).
  - b. Remove the split ring (7) to separate the lock nut from the bonnet.
  - c. Remove the o-ring seal(s) (4) from the bonnet.
4. For size 3":
  - a. Loosen the bonnet (3) and remove from the valve body (1).
  - b. Remove the o-ring seal (4) from the groove on the valve body.
5. Remove the piston (2) from the valve body and then the flat gasket (5) from the piston.
6. The valve components can now be checked for problems and/or replaced.

#### Assembly

**Note:** Before assembling the valve components, it is advisable to lubricate the o-rings with a water soluble lubricant. **Be sure to consult the "IPEX Chemical Resistance Guide" and/or other trusted resources to determine specific lubricant-rubber compatibilities.**

1. Properly fit the flat gasket (5) in the groove on the piston (2) then insert into the valve body (1).
2. For sizes 1/2" through 2" and 4":
  - a. Properly fit the o-ring seal(s) (4) onto the bonnet.
  - b. Place the lock nut (6) over the bonnet (3) then fit the split ring (7) in the groove to lock in position.
  - c. Insert the lock nut (6) – bonnet (3) assembly into the valve body and tighten.
3. For size 3":
  - a. Properly fit the o-ring seal (4) in the groove on the valve body.
  - b. Tighten the bonnet (3) into the valve body.
4. For true union style, ensure that the socket o-rings (8) are properly fitted in their grooves, place the end connectors into the union nuts (10), then tighten onto the valve body.



## SC SERIES SWING CHECK VALVES

IPEX SC Swing Check Valves combine superior flow rate with maximum versatility. Stainless wetted parts and hardware, a top entry design, and integral flanged ends are just a few key features. With extremely low back pressure requirements, these valves are ideal for back-flow prevention in large diameter lines, both horizontal and vertical. SC Swing Check Valves are part of our complete Xirtec®140 systems of pipe, valves, and fittings, engineered and manufactured to our strict quality, performance, and dimensional standards.

### Valve Availability

Body Material:	PVC
Size Range:	3" through 8"
Pressure:	100psi (3") 70psi (4" to 8")
Seals:	EPDM, Viton® (FPM)
End Connections:	Flanged (ANSI 150)



ASTM D1784



ANSI B16.5



## SC SERIES SWING CHECK VALVES

### Sample Specification

#### 1.0 Check Valves - SC

##### 1.1 Material

- The valve body, bonnet, swing arm, and disc shall be made of PVC compound which shall meet or exceed the requirements of cell classification 12454 according to ASTM D1784.

##### 1.2 Seals

- The o-ring seals and shutter shall be made of EPDM.
- or
- The o-ring seals and shutter shall be made of Viton® (FPM).

##### 1.3 Bolts

- The bolts, nuts, and washers shall be made of 304 stainless steel.

1.4 All wetted parts of the valves shall comply with standards that are equivalent to NSF Standard 61 for potable water.

#### 2.0 Connections

##### 2.1 Flanged style

- The ANSI 150 flanged PVC end connections shall conform to the dimensional standard ANSI B16.5.

#### 3.0 Design Features

- All swing check valves shall be full flow.
- All valves shall be gravity operated.
- The valve shall have a full face disc seal.
- The valve shall have a full open disc stop to prevent over-travel.
- The valve shall have no wetted metal parts.
- Service of the valve shall be possible without removal from the system line.
- All check valves may be installed in either horizontal or vertical orientations.

##### 3.1 Pressure Rating

- Valve sizes 3" shall be rated at 100psi at 73°F (23°C).
- Valve sizes 4" through 8" shall be rated at 70psi at 73°F (23°C).

##### 3.2 Markings

- All valves shall be marked to indicate size, material designation, and manufacturers name or trade mark.

##### 3.3 Color Coding

- All PVC valves shall be color-coded dark gray.

4.0 All valves shall be Xirtec® 140 by IPEX or approved equal.

## SC SERIES SWING CHECK VALVES

### Dimensions and Weights

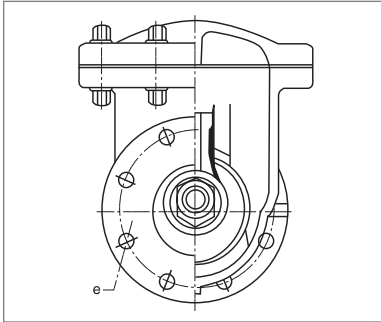
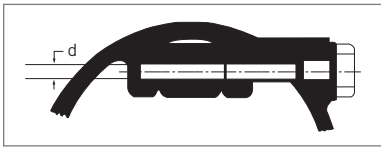

Dimension (inches)								
Size	D1	D2	D3	D4	D5	D6	e	# holes
3	3.16	6.00	7.50	7.13	8.06	5.13	0.75	4
4	3.94	7.50	9.00	9.25	10.44	6.69	0.75	8
6	5.53	9.50	11.00	13.00	14.56	9.84	0.88	8
8	7.88	11.75	13.50	15.31	16.71	11.81	0.88	8

Dimension (inches)							
Size	L	T	A	h	H	d	W (lbs)
3	10.25	0.79	0.34	2.75	6.72	0.47	8.25
4	11.82	0.90	0.41	3.53	8.38	0.63	19.40
6	15.75	1.20	0.63	5.31	10.56	0.78	28.66
8	16.69	1.22	0.72	6.69	12.06	0.78	46.30

### Flow Coefficients

Size	C <sub>v</sub>
3	300
4	480
6	1100
8	1900

### Pressure – Temperature Ratings

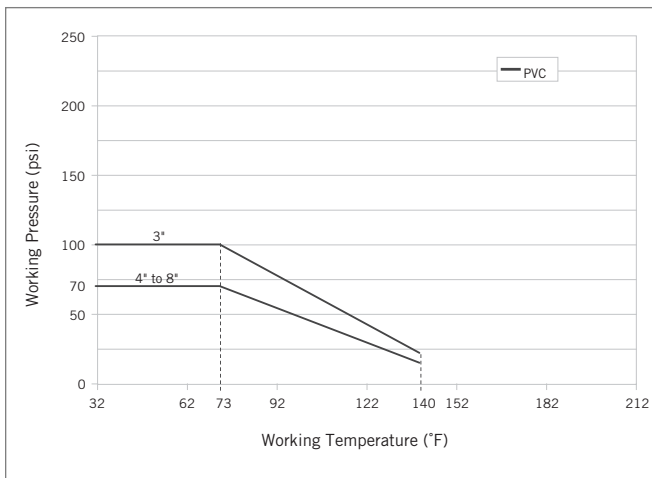

### Pressure Loss Chart

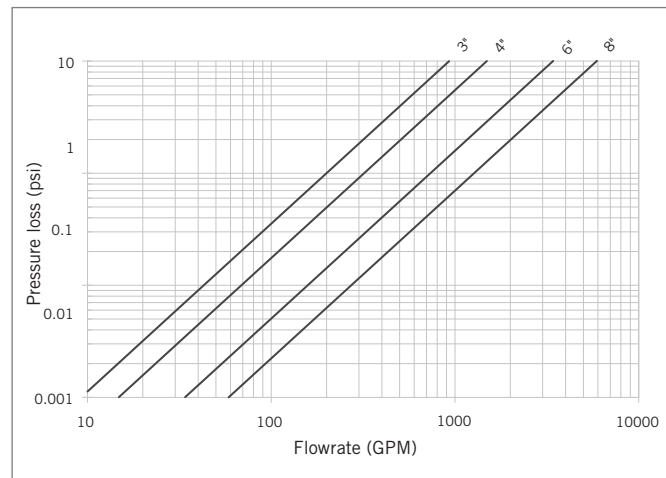

CHECK & VENT VALVES

## SC SERIES SWING CHECK VALVES

### Components

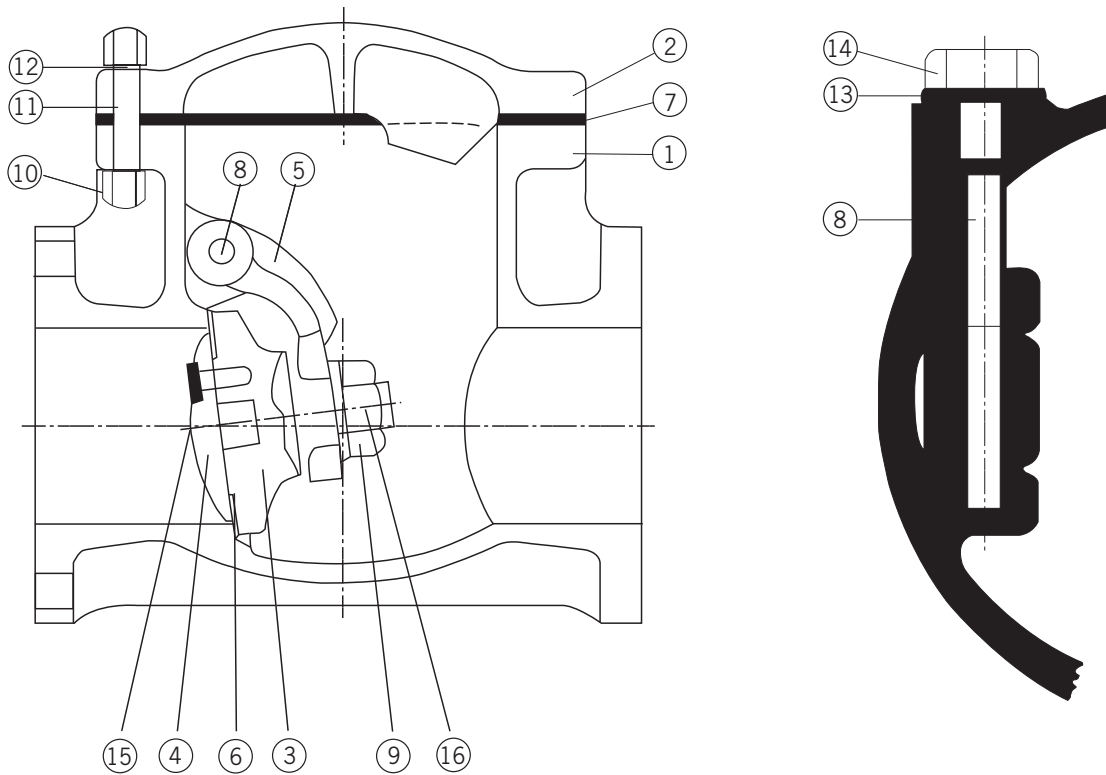

#	Component	Material	Qty
1	body	PVC	1
2	bonnet	PVC	1
3	disc	PVC	1
4	gasket holder	PVC	1
5	swing arm	PVC	1
6	disc gasket	EPDM or Viton®	1
7	bonnet gasket	EPDM or Viton®	1
8	shaft	PVC	1
9	disc holder	PVC	1
10	bolts	SUS 304	6 (3"), 8 (4" to 8")
11	nuts	SUS 304	6 (3"), 8 (4" to 8")
12	washers	SUS 304	6 (3"), 8 (4" to 8")
13	o-ring	EPDM or Viton®	1
14	shaft holder	PVC	1
15	set bolts	PVC	3 (3"), 4 (5" to 6"), 8 (8")
16	set pin	PVC	1

## SC SERIES SWING CHECK VALVES

### Installation Procedures

1. Ensure that the valve is in the correct orientation then carefully place the valve in the system between the two pipe flanges.
2. Join each end of the valve to the pipe flanges. For correct joining procedure, please refer to the section entitled, “*Joining Methods – Flanging*” in the IPEX Industrial Technical Manual Series, “*Volume I: Vinyl Process Piping Systems*”.



### Valve Maintenance

#### Disassembly

1. If removing the valve from an operating system, isolate the valve from the rest of the system. **Be sure to depressurize and drain the isolated branch and valve before continuing.**
2. Loosen end of the valve from the pipe flanges. Please refer to the section entitled, “*Joining Methods – Flanging*” in the IPEX Industrial Technical Manual Series, “*Volume I: Vinyl Process Piping Systems*” for a recommended bolt tightening pattern diagram. Follow the same pattern when disassembling the flanged joints.
3. Carefully remove the valve from the line.
4. Loosen and remove the nuts (10), bolts (11), and washers (12) then remove the bonnet (2) and gasket (7) from the top of the valve body (1).
5. Loosen the shaft holder (14) and remove the o-ring (13).
6. Remove the shaft (8) then take the swing arm (5) assembly out of the valve.
7. To disassemble the swing arm, loosen the set bolt(s) (15) then remove the gasket holder (4) and disc gasket (6) from the disc (3).
8. The valve components can now be checked for problems and/or replaced.

**Note:** The disc and disc holder (9) are permanently fixed to the swing arm by the set pin (16) and cannot be disassembled.

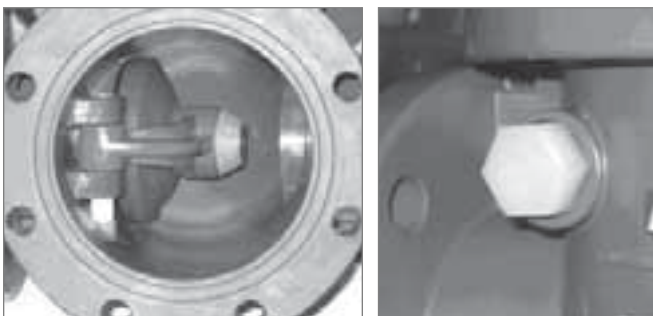

#### Assembly

**Note:** Before assembling the valve components, it is advisable to lubricate the o-rings with a water soluble lubricant. **Be sure to consult the “IPEX Chemical Resistance Guide” and/or other trusted resources to determine specific lubricant-rubber compatibilities.**

1. Assemble the swing arm (5) components by placing the disc gasket (6) and gasket holder (4) on the disc (3) then tightening the set bolt(s) (15).
2. Place the swing arm assembly into the valve body (1) then insert the shaft (8) through the mounting holes.
3. Fit the o-ring (13) on the shaft holder (14) then sufficiently tighten into the valve body.
4. Taking care to line up all the holes, place the gasket (7) and bonnet (2) onto the valve body.
5. Insert and tighten all nuts (10), bolts (11), and washers (12) according to a proper flange bolt tightening pattern.



## VA SERIES AIR RELEASE VALVES

IPEX VA Air Release Valves are of a unique design, controlled by media and not pressure. Intended for use with tanks, slurries, and start-ups amongst other things, these 232psi pressure rated valves will economically and efficiently eliminate air or gas pockets. This no-spill valve also relieves potentially dangerous vacuums that may build up in the piping system. VA Air Release Valves are part of our complete Xirtec®140 systems of pipe, valves, and fittings, engineered and manufactured to our strict quality, performance, and dimensional standards.

### Valve Availability

Body Material:	PVC
Size Range:	3/4", 1-1/4", 2"
Pressure:	232psi
Seals:	EPDM, Viton® (FPM)
End Connections:	Threaded (FNPT) Inlet Socket (IPS) and Threaded (FNPT) Outlets



ASTM D1784  
ASTM D2464  
ASTM F437  
ASTM F1498



ANSI B1.20.1



## VA SERIES AIR RELEASE VALVES

### Sample Specification

#### 1.0 Air Release Valves - VA

##### 1.1 Material

- The valve body, piston, end connectors, and union shall be made of PVC compound which shall meet or exceed the requirements of cell classification 12454 according to ASTM D1784.

##### 1.2 Seals

- The o-ring seals shall be made of EPDM.
- or The o-ring seals shall be made of Viton®(FPM).

- ##### 1.3 All wetted parts of the valves shall comply with standards that are equivalent to NSF Standard 61 for potable water.

#### 2.0 Connections

##### 2.1 Threaded style

- The female NPT threaded PVC end connectors shall conform to the dimensional standards ASTM D2464, ASTM F1498, and ANSI B1.20.1.

#### 3.0 Design Features

- The valve shall be of single union design.

- The valve sealing mechanism shall be a hollow piston.
- Opening and closing of the valve shall not be affected by pressure.
- The valve shall close when liquid is in contact with the piston.
- The valve shall open when air or gas is in contact with the piston.
- The valve shall also function as a vacuum breaker.
- The valve body and union nut shall have deep square style threads for increased strength.

#### 3.1 Pressure Rating

- All valves shall be rated at 232psi at 73°F (23°C).

#### 3.2 Markings

- All valves shall be marked to indicate size, material designation, and manufacturers name or trade mark.

#### 3.3 Color Coding

- All PVC valves shall be color-coded dark gray.

- #### 4.0 All valves shall be Xirtec® 140 by IPEX or approved equal.

### Dimensions and Weights

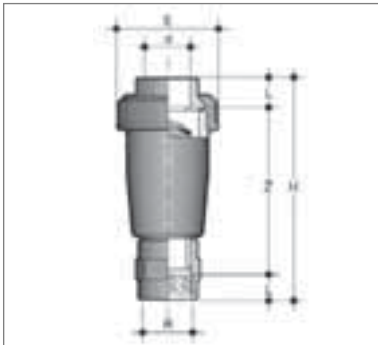

Top IPS Socket Connection - Dimension (inches)						
Size	d	E	L	Z	H	W (lbs)
3/4	1.05	2.60	0.64	4.58	5.87	0.45
1-1/4	1.66	3.43	0.84	6.19	7.87	1.05
2	2.38	4.72	1.01	7.74	9.76	2.49

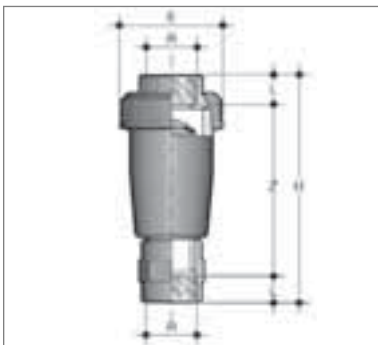

Top Female NPT Threaded Connection - Dimension (inches)						
Size	R	E	L	Z	H	W (lbs)
3/4	3/4 NPT	2.60	0.64	4.58	5.87	0.45
1-1/4	1-1/4 NPT	3.43	0.84	6.19	7.87	1.05
2	2 NPT	4.72	1.01	7.74	9.76	2.49

CHECK & VENT VALVES

## VA SERIES AIR RELEASE VALVES

### Air Flow Chart

Size (inches)	Maximum Air Flow / Air Velocity Relationship											
	20psi g		40psi g		60psi g		80psi g		100psi g		120psi g	
	F	V	F	V	F	V	F	V	F	V	F	V
3/4	19	39	36	47	54	52	72	54	91	57	110	58
1-1/4	67	54	127	65	188	70	250	74	313	76	376	78
2	177	69	331	82	491	89	652	93	814	96	980	99

F = Air Flow (scfm), V = Air Velocity (ft/s)

### Pressure – Temperature Ratings

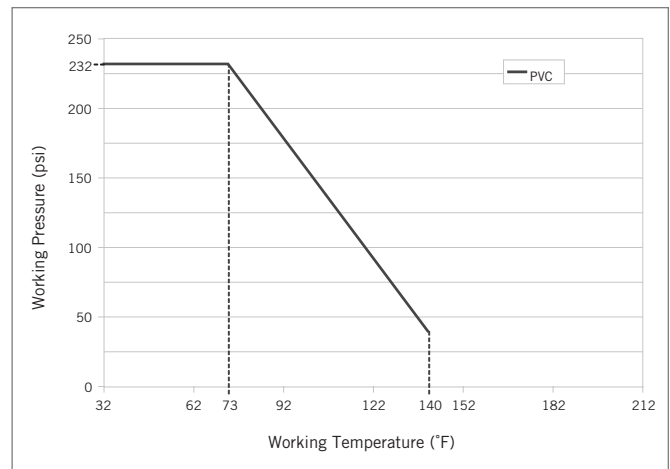

### Components

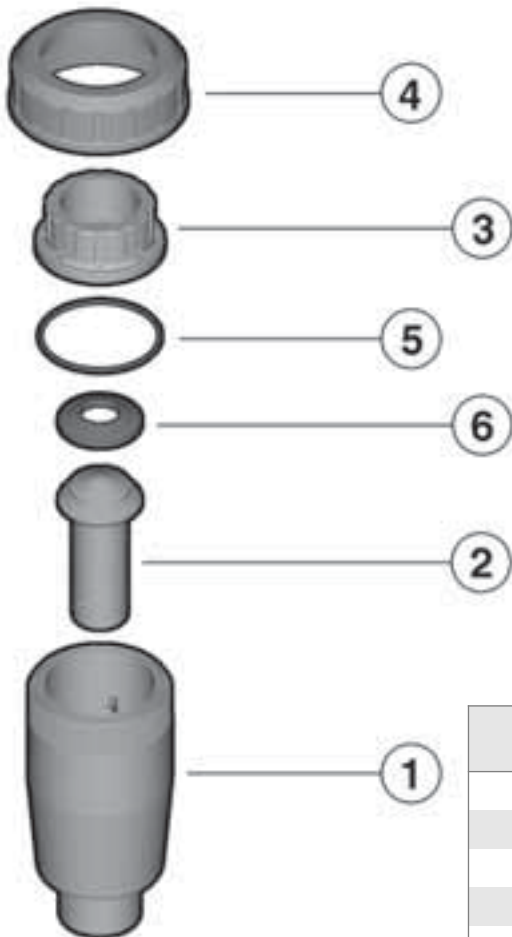

#	Component	Material	Qty
1	body	PVC	1
2	piston	PVC	1
3	end connector	PVC	1
4	union nut	PVC	1
5	body o-ring	EPDM or Viton®	1
6	piston o-ring	EPDM or Viton®	1

## VA SERIES AIR RELEASE VALVES

### Installation Procedures

1. Remove the union nut (part #4 on previous page) and slide it onto the outlet stack pipe. The valve must always be installed in a vertical orientation with the union nut joint at the top.
2. Please refer to the appropriate connection style sub-section:
  - a. For socket style, solvent cement the end connector (3) onto the outlet stack pipe end. For correct joining procedure, please refer to the section entitled, *“Joining Methods – Solvent Cementing”* in the IPEX Industrial Technical Manual Series, *“Volume I: Vinyl Process Piping Systems”*. **Be sure to allow sufficient cure time before continuing with the valve installation.**
  - b. For threaded style, thread the end connector (3) onto the outlet stack pipe end. For correct joining procedure, please refer to the section entitled, *“Joining Methods – Threading”* in the IPEX Industrial Technical Manual Series, *“Volume I: Vinyl Process Piping Systems”*.
3. Remove the piston (2) then thread the valve body (1) onto the inlet pipe and sufficiently tighten with a wrench.
4. Ensure that the piston o-ring (6) is properly fitted in its groove, then replace the piston inside the valve body.
5. Ensure that the body o-ring (5) is properly fitted in its groove, then install the outlet stack pipe and tighten the union nut. Hand tightening is typically sufficient to maintain a seal for the maximum working pressure. Over-tightening may damage the threads on the valve body and/or the union nut, and may even cause the union nut to crack.

**Note:** When used for corrosive chemical applications, a minimum 18 inch outlet stack must be installed.



### Valve Maintenance

#### Disassembly

1. If removing the valve from an operating system, isolate the valve from the rest of the system. **Be sure to depressurize and drain the isolated branch and valve before continuing.**
2. Loosen the union nut (4) and remove the outlet stack pipe. If retaining the body o-ring (5), take care that it is not lost when removing the valve from the line.
3. Remove the piston (2) from the valve body (1).
4. Loosen and remove the valve body from the inlet pipe.
5. Remove the piston o-ring (6) from the piston.
6. The valve components can now be checked for problems and/or replaced.

#### Assembly

**Note:** Before assembling the valve components, it is advisable to lubricate the o-rings with a water soluble lubricant. **Be sure to consult the “IPEX Chemical Resistance Guide” and/or other trusted resources to determine specific lubricant-rubber compatibilities.**

1. Properly fit the piston o-ring (6) in the groove on the piston (2).
2. Insert the piston into the valve body (1).
3. Properly fit the body o-ring (5) in the groove on the valve body.
4. Position the end connector (3) on the valve body.
5. Position the union nut (4) on the valve body and tighten.





## SECTION SIX: SPECIALTY VALVES

### RV SERIES SEDIMENT STRAINERS

IPEX RV Sediment Strainers protect critical pipeline components by removing solids and suspended impurities. Clear PVC construction allows for inspection of the screen while in service, whereas the bottom-entry design permits maintenance on the valve while in-line. This Y-pattern strainer is also available in Corzan® CPVC. RV RV Sediment Strainers are part of our complete Xirtec®140 and Corzan® systems of pipe, valves, and fittings, engineered and manufactured to our strict quality, performance, and dimensional standards.

#### Valve Availability

Body Material:	PVC, CPVC
Size Range:	1/2" through 4"
Pressure:	232psi (1/2" to 1") 150psi (1-1/4" to 2") 60psi (3" to 4")
Seals:	EPDM, Viton® (FPM)
End Connections:	Socket (IPS) Threaded (FNPT) Flanged (ANSI 150)



ASTM D1784  
ASTM D2464  
ASTM D2466  
ASTM D2467  
ASTM D4101  
ASTM F437  
ASTM F439  
ASTM F1498



ANSI B1.20.1  
ANSI B16.5



## RV SERIES SEDIMENT STRAINERS

### Sample Specification

#### 1.0 Sediment Strainers - RV

##### 1.1 Material

- The valve body, end connectors, and unions shall be made of PVC compound which shall meet or exceed the requirements of cell classification 12454 according to ASTM D1784.
- or The valve body, end connectors, and unions shall be made of Corzan® CPVC compound which shall meet or exceed the requirements of cell classification 23447 according to ASTM D1784.

##### 1.2 Seals

- The o-ring seals shall be made of EPDM.
- or The o-ring seals shall be made of Viton® (FPM).

##### 1.3 Mesh Screen

- The mesh screen shall be made of PVC compound which shall meet or exceed the requirements of cell classification 12454 according to ASTM D1784.
- or The mesh screen shall be made of stabilized PP homopolymer compound, also containing a RAL 7032 pigment, which shall meet or exceed the requirements of Type I Polypropylene according to ASTM D4101.
- or The mesh screen shall be made of corrosion resistant 304 stainless steel.

**1.4** All wetted parts of the valves shall comply with standards that are equivalent to NSF Standard 61 for potable water.

#### 2.0 Connections

##### 2.1 Socket style

- The IPS socket PVC end connectors shall conform to the dimensional standards ASTM D2466 and ASTM D2467.
- or The IPS socket CPVC end connectors shall conform to the dimensional standard ASTM F439.

##### 2.2 Threaded style

- The female NPT threaded PVC end connectors shall conform to the dimensional standards ASTM D2464, ASTM F1498, and ANSI B1.20.1
- or The female NPT threaded CPVC end connectors shall conform to the dimensional standards ASTM F437, ASTM F1498, and ANSI B1.20.1.

##### 2.3 Flanged style

- The ANSI 150 flanged PVC end connectors shall conform to the dimensional standard ANSI B16.5.
- or The ANSI 150 flanged CPVC end connectors shall conform to the dimensional standard ANSI B16.5

#### 3.0 Design Features

- Strainers shall be Y-pattern in style.
- Sizes 1/2" through 2" shall have true union ends.
- Sizes 3" and 4" shall have solid threaded or socket ends.
- It shall be possible to service the valve without removing it from the line.
- PVC strainers shall have a transparent body for evaluation of filter screen condition.
- The filter screens shall be available in ASTM 18, 30, 35, and 50 mesh sizes.

##### 3.1 Pressure Rating

- PVC valve sizes 1/2" through 1" shall be rated at 232psi at 73°F (23°C).
- CPVC valve sizes 1/2" through 2" shall be rated at 232psi at 73°F (23°C).
- PVC valve sizes 1-1/4" through 2" shall be rated at 150psi at 73°F (23°C).
- PVC valve sizes 3" through 4" shall be rated at 60psi at 73°F (23°C).
- All sizes of flanged valves shall be rated at no greater than 150psi at 73°F (23°C).

##### 3.2 Markings

- All valves shall be marked to indicate size, material designation, and manufacturers name or trade mark.

##### 3.3 Color Coding

- All PVC valves shall have transparent bodies with end connections color-coded dark gray.
- or All CPVC valves shall be color-coded light gray.

**4.0** All valves shall be Xirtec® 140 or Corzan® by IPEX or approved equal.

## RV SERIES SEDIMENT STRAINERS

### Mesh Availability

ASTM Mesh Size	Hole Pitch (in)	Material		
		PVC	PP	304 SS
18	3/32	✓	-	-
30	5/64	✓	-	-
30	1/16	-	✓	-
35	1/32	✓	-	✓
50	3/64	✓	-	-

### Dimensions

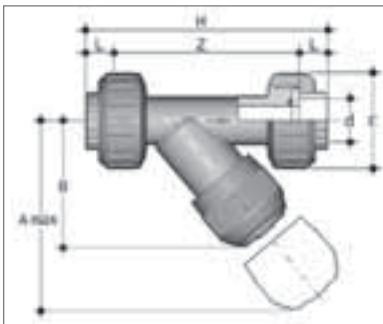

IPS Socket Connections - Dimension (inches)							
Size	d	L	Z	H	E	B	A <sub>max</sub>
1/2	0.84	0.63	4.06	5.31	2.17	2.83	4.92
3/4	1.05	0.75	4.72	6.22	2.60	3.31	5.71
1	1.32	0.87	5.20	6.93	2.95	3.74	6.50
1-1/4	1.66	1.02	6.10	8.15	3.43	4.37	7.48
1-1/2	1.90	1.22	7.13	9.57	3.94	4.72	8.27
2	2.38	1.50	8.72	11.73	4.72	5.47	9.45

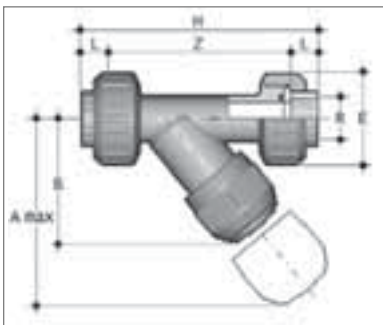

Female NPT Threaded Connections - Dimension (inches)							
Size	R	L	Z	H	E	B	A <sub>max</sub>
1/2	1/2-NPT	0.59	4.45	5.63	2.17	2.83	4.92
3/4	3/4-NPT	0.64	5.02	6.30	2.60	3.31	5.71
1	1-NPT	0.75	5.70	7.20	2.95	3.74	6.50
1-1/4	1-1/4-NPT	0.84	6.74	8.43	3.43	4.37	7.48
1-1/2	1-1/2-NPT	0.84	7.57	9.25	3.94	4.72	8.27
2	2-NPT	1.01	9.20	11.22	4.72	5.47	9.45

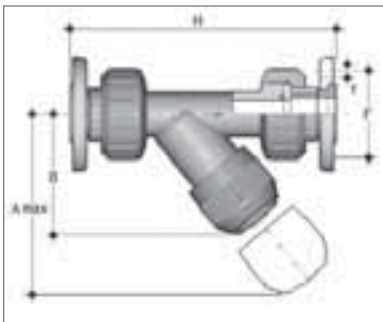

ANSI 150 Flanged (Vanstone) Connections - Dimension (inches)						
Size	# holes	f	F	H	B	A <sub>MAX</sub>
1/2	4	5/8	2-3/8	7.13	2.83	4.92
3/4	4	5/8	2-3/4	8.16	3.31	5.71
1	4	5/8	3-1/8	9.05	3.74	6.50
1-1/4	4	5/8	3-1/2	10.34	4.37	7.48
1-1/2	4	5/8	3-7/8	12.07	4.72	8.27
2	4	3/4	4-3/4	14.48	5.47	9.45

## RV SERIES SEDIMENT STRAINERS

### Dimensions (cont'd)

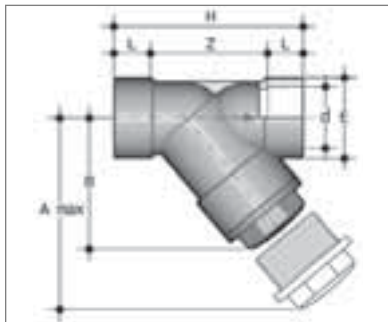

IPS Socket Connections - Dimension (inches)							
Size	R	L	Z	H	E	B	A <sub>max</sub>
3	3.50	2.01	6.30	10.31	4.57	7.56	12.80
4	4.50	2.40	7.99	12.80	5.43	9.09	15.16

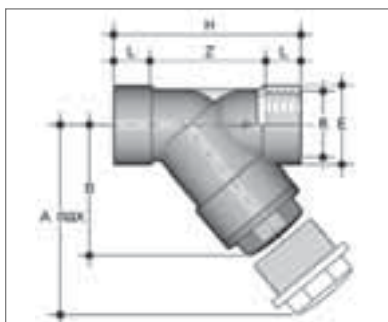

Female NPT Threaded Connections - Dimension (inches)							
Size	R	L	Z	H	E	B	A <sub>max</sub>
3	3-NPT	1.31	7.69	10.31	4.57	7.56	12.80
4	4-NPT	1.55	9.70	12.80	5.43	9.09	15.16

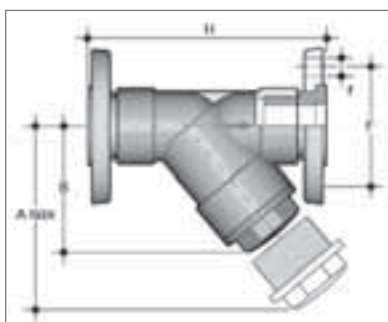

ANSI 150 Flanged (Vanstone) Connections - Dimension (inches)						
Size	# holes	f	F	H	B	A <sub>max</sub>
3	4	3/4	6	12.81	7.56	12.80
4	8	3/4	7-1/2	15.62	9.09	15.16

### Screen Data

Valve Size	Filter Surface Area (in <sup>2</sup> )
1/2	152
3/4	232
1	342
1-1/4	445
1-1/2	652
2	1271
3	1594
4	2555

ASTM Mesh Size	Hole Pitch (in)	# Holes per in <sup>2</sup>	Equivalent Hole Diameter (mm)	Screen Material
18	3/32	226	900	PVC
30	5/64	387	600	PVC
30	1/16	645	600	PP
35	1/32	645	500	PVC
35	1/32	1548	500	304 SS
50	3/64	1226	300	PVC

## RV SERIES SEDIMENT STRAINERS

### Weights

Size (in)	Approximate Weight (lbs)				
	PVC			CPVC	
	IPS Socket	FNPT Threaded	ANSI Flanged	IPS Socket	FNPT Threaded
1/2	0.47	0.46	0.87	0.51	0.51
3/4	0.79	0.78	1.37	0.86	0.86
1	1.16	1.15	1.94	1.27	1.27
1-1/4	1.62	1.64	2.62	1.77	1.79
1-1/2	2.41	2.44	3.61	2.64	2.67
2	4.06	4.13	5.94	4.45	4.52
3	6.56	6.54	10.30	n/a	n/a
4	10.16	9.71	16.16	n/a	n/a

### Pressure – Temperature Ratings

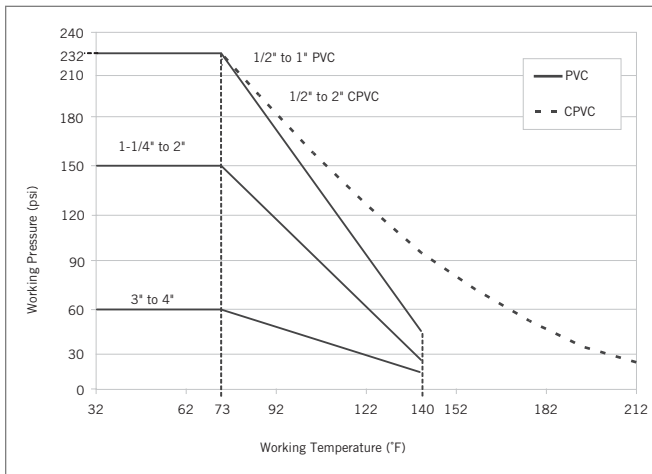

### Flow Coefficients

Size	Cv
1/2	2.80
3/4	4.90
1	7.21
1-1/4	13.2
1-1/2	17.9
2	28.7
3	73.5
4	119

### Pressure Loss Chart

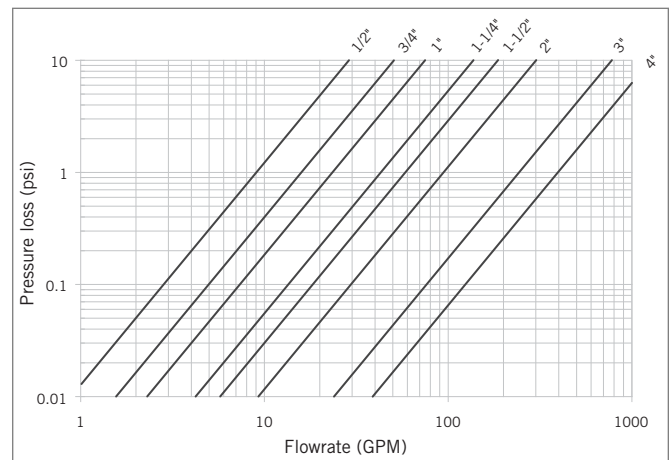

## RV SERIES SEDIMENT STRAINERS

### Components

Sizes 1/2" through 2"

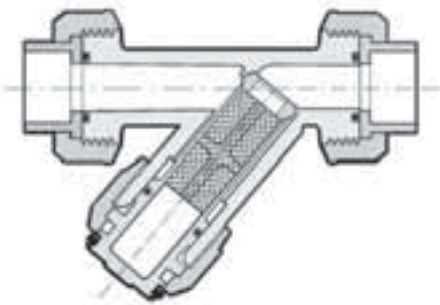
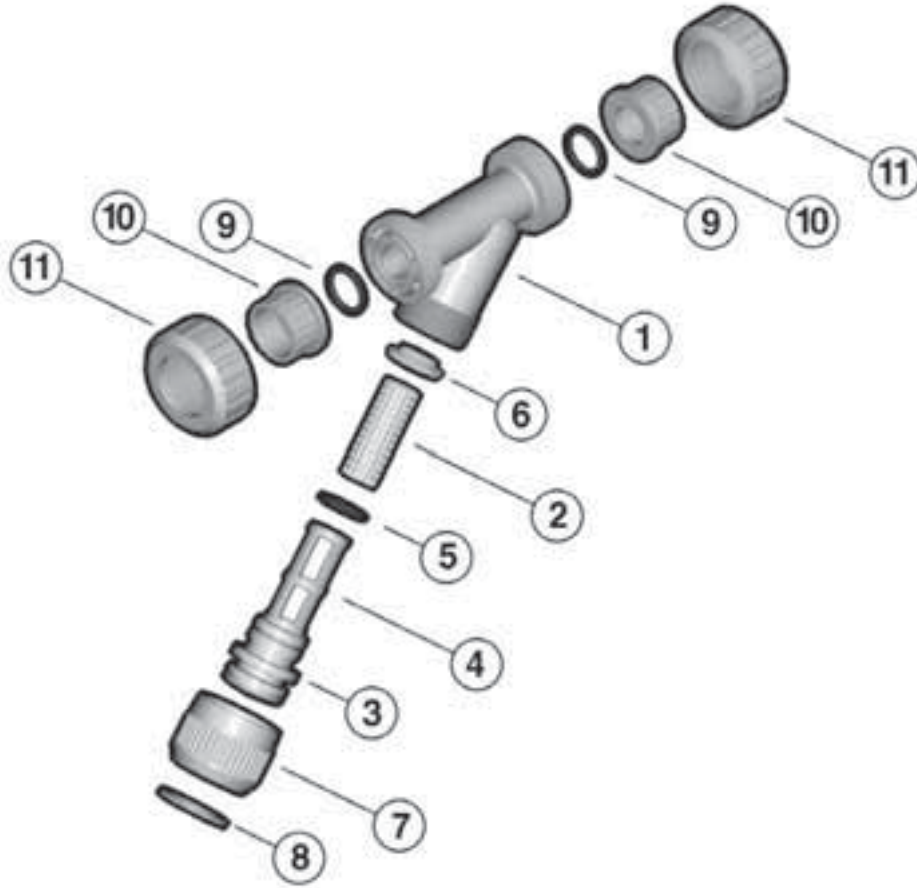

#	Component	Material	Qty
1	body	PVC / CPVC	1
2*	screen mesh	PVC / PP / 304 SS	1
3*	bonnet	PVC / CPVC	1
4*	screen support	PVC / CPVC	1
5*	o-ring seal	EPDM or Viton®	1
6*	retaining ring	PVC / CPVC	1
7*	lock nut	PVC / CPVC	1
8*	split ring	PVC / CPVC	1
9*	socket o-ring	EPDM or Viton®	2
10*	end connector	PVC / CPVC	2
11*	union nut	PVC / CPVC	2

\* Spare parts available.

## RV SERIES SEDIMENT STRAINERS

### Components (cont'd)

### Size 3"

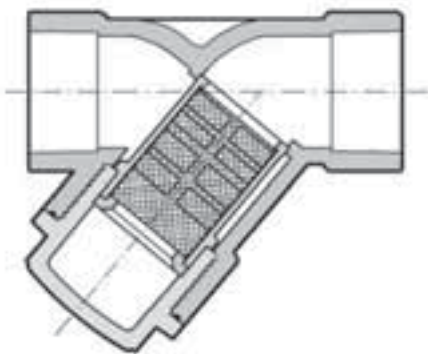
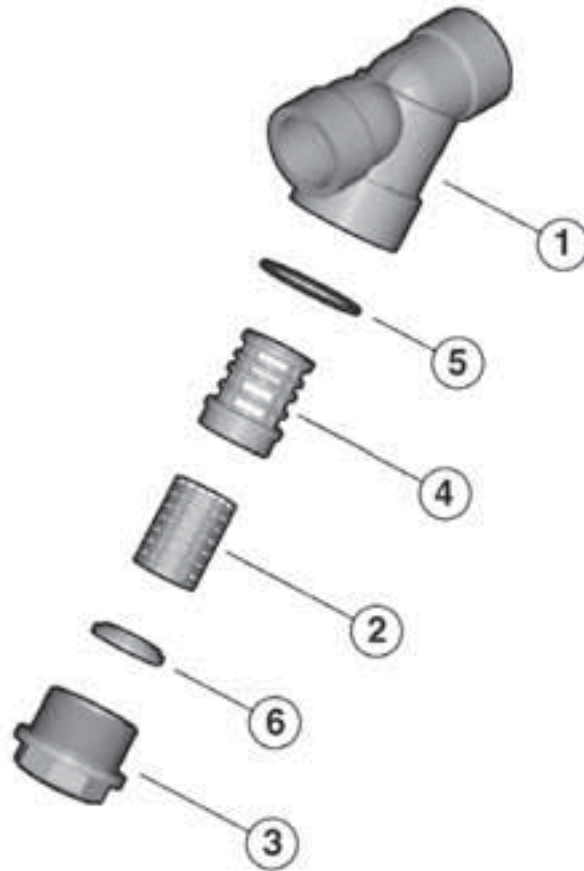

#	Component	Material	Qty
1	body	PVC / CPVC	1
2*	screen mesh	PVC / 304 SS	1
3*	bonnet	PVC	1
4*	screen support	PVC	1
5*	o-ring seal	EPDM or Viton®	1
6*	retaining ring	PVC	1

\* Spare parts available.

## RV SERIES SEDIMENT STRAINERS

Components (cont'd)

Size 4"

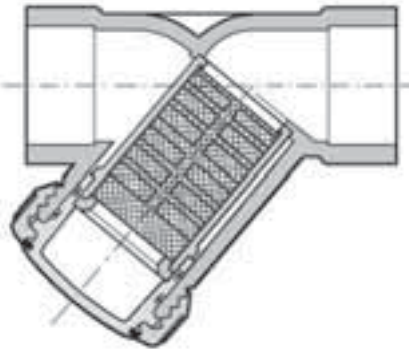
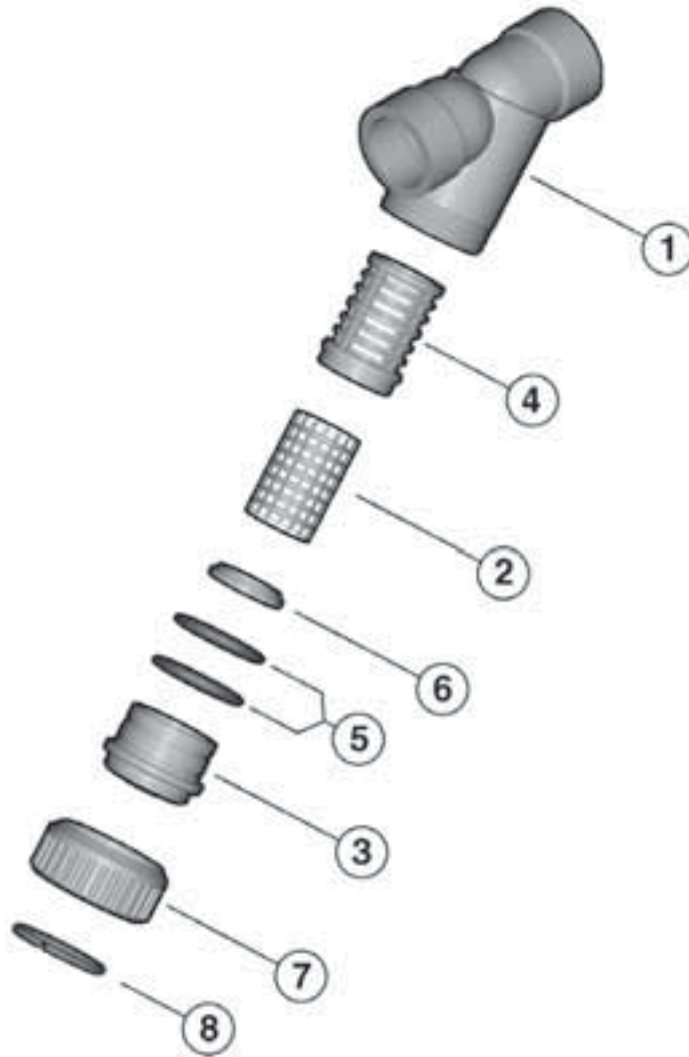

#	Component	Material	Qty
1	body	PVC / CPVC	1
2*	screen mesh	PVC / 304 SS	1
3*	bonnet	PVC	1
4*	screen support	PVC	1
5*	o-ring seal	EPDM or Viton®	1
6*	retaining ring	PVC	1
7*	lock nut	PVC	1
8*	split ring	PVC	1

\* Spare parts available.

## RV SERIES SEDIMENT STRAINERS

### Installation Procedures

#### True Union Style:

1. For socket and threaded style connections, remove the union nuts (part #11 on previous pages) and slide them onto the pipe. For flanged connections, remove the union nut / flange assemblies from the valve.
2. Please refer to the appropriate connection style sub-section:
  - a. For socket style, solvent cement the end connectors (10) onto the pipe ends. For correct joining procedure, please refer to the section entitled, *“Joining Methods – Solvent Cementing”* in the IPEX Industrial Technical Manual Series, *“Volume I: Vinyl Process Piping Systems”*. **Be sure to allow sufficient cure time before continuing with the valve installation.**
  - b. For threaded style, thread the end connectors (10) onto the pipe ends. For correct joining procedure, please refer to the section entitled, *“Joining Methods – Threading”* in the IPEX Industrial Technical Manual Series, *“Volume I: Vinyl Process Piping Systems”*.
  - c. For flanged style, join the union nut / flange assemblies to the pipe flanges. For correct joining procedure, please refer to the section entitled, *“Joining Methods – Flanging”* in the IPEX Industrial Technical Manual Series, *“Volume I: Vinyl Process Piping Systems”*.
3. Ensure that the valve is in the correct orientation (the bonnet should be suspended in a downward direction), and that the socket o-rings (9) are properly fitted in their grooves. Carefully place the valve in the system between the two end connections.
4. Tighten both union nuts and the lock nut (7). Hand tightening is typically sufficient to maintain a seal for the maximum working pressure. Over-tightening may damage the threads on the valve body and/or the nut, and may even cause the nut to crack.

#### Non True Union Style:

2. Please refer to the appropriate connection style sub-section:
  - a. For socket style, ensure that the valve is in the correct orientation (the bonnet should be suspended in a downward direction) then solvent cement the end connections of the valve body (1) to the pipe ends. For correct joining procedure, please refer to the section entitled, *“Joining Methods – Solvent Cementing”* in the IPEX Industrial Technical Manual Series, *“Volume I: Vinyl Process Piping Systems”*. Ensure that no excess solvent runs into the body as this would cause severe damage to internal components and render the strainer inoperative. **Be sure to allow sufficient cure time before continuing with the valve installation.**
  - b. For threaded style, ensure that the valve is in the correct orientation (the bonnet should be suspended in a downward direction) then thread the pipe ends into the valve body (1). For correct joining procedure, please refer to the section entitled, *“Joining Methods – Threading”* in the IPEX Industrial Technical Manual Series, *“Volume I: Vinyl Process Piping Systems”*.
  - c. For flanged style, ensure that the valve is in the correct orientation (the bonnet should be suspended in a downward direction) then join to the pipe flanges. For correct joining procedure, please refer to the section entitled, *“Joining Methods – Flanging”* in the IPEX Industrial Technical Manual Series, *“Volume I: Vinyl Process Piping Systems”*.
3. Ensure that the bonnet (3, size 3") or lock nut (7, size 4") is sufficiently tightened. Hand tightening is typically sufficient to maintain a seal for the maximum working pressure. Over-tightening may damage the threads on the valve body and/or the nut, and may even cause the nut to crack.



## RV SERIES SEDIMENT STRAINERS

### Valve Maintenance

#### Disassembly

1. If removing the valve from an operating system, isolate the valve from the rest of the system. **Be sure to depressurize and drain the isolated branch and valve before continuing.**
2. For true union style, loosen both union nuts (11) and drop the valve out of the line. If retaining the socket o-rings (9), take care that they are not lost when removing the valve from the line.
3. For sizes 1/2" through 2" and 4":
  - a. Loosen the lock nut (7) – bonnet (3) assembly and remove from the valve body (1).
  - b. Remove the split ring (8) to separate the lock nut from the bonnet.
  - c. Remove the retaining ring (6) and slide the screen mesh (2) out of the screen support (4).
  - d. Remove the o-ring seal(s) (5) from the bonnet.
4. For size 3":
  - a. Loosen the bonnet (3) and remove from the valve body (1).
  - b. Remove the retaining ring (6) and slide the screen mesh (2) out of the screen support (4).
  - c. Remove the o-ring seal(s) (5) from the groove on the valve body.
5. The valve components can now be checked for problems and/or replaced.

#### Assembly

Note: Before assembling the valve components, it is advisable to lubricate the o-rings with a water soluble lubricant. **Be sure to consult the "IPEX Chemical Resistance Guide" and/or other trusted resources to determine specific lubricant-rubber compatibilities.**

1. For sizes 1/2" through 2" and 4":
  - a. Properly fit the o-ring seal(s) (5) onto the bonnet (3).
  - b. Insert the screen mesh (2) into the screen support (4) and fasten with the retaining ring (6).
  - c. Place the lock nut (7) over the bonnet then fit the split ring (8) in the groove to lock in position.
  - d. Insert the screen and lock nut – bonnet assembly into the valve body (1) and tighten.
2. For size 3":
  - a. Properly fit the o-ring seal (5) onto the bonnet (1).
  - b. Insert the screen mesh (2) into the screen support (4) and fasten with the retaining ring (6).
  - c. Insert the screen assembly into the valve body.
  - d. Tighten the bonnet (3) into the valve body.
3. For true union style, ensure that the socket o-rings (9) are properly fitted in their grooves, place the end connectors (10) into the union nuts (11), then tighten onto the valve body.



## SF SERIES SOLENOID VALVES

IPEX SF 2-way Solenoid Valves are flow control valves designed for precise control and high-cycle service. A 100% duty cycle means no worries about overheating or “burnout”. With their lever-shutter design, standard manual override, and position indicator, these valves will outlast and outperform more conventional diaphragm-style solenoid valves. SF Solenoid Valves are part of our complete Xirtec®140 systems of pipe, valves, and fittings, engineered and manufactured to our strict quality, performance, and dimensional standards.

### Valve Availability

Body Material:	PVC
Size Range:	1/4" through 1/2"
Pressure:	60psi (ND 0.24 & 0.39) 30psi (ND 0.31)
Seals:	EPDM, Viton® (FPM)
End Connections:	Threaded (FNPT)



ASTM D1784  
ASTM D2464  
ASTM F437  
ASTM F1498



ANSI B1.20.1



## SF SERIES SOLENOID VALVES

### Sample Specification

#### 1.0 Solenoid Valves - SF

##### 1.1 Material

- The valve body, end connectors, and unions shall be made of PVC compound which shall meet or exceed the requirements of cell classification 12454 according to ASTM D1784.
- The coil housing shall be made of glass filled Polypropylene with a non-filled Polypropylene thermal shield between the body and coil.

##### 1.2 Seals

- The o-ring seals and shutter shall be made of EPDM.
- or The o-ring seals and shutter shall be made of Viton® (FPM).

- 1.3** All wetted parts of the valves shall comply with standards that are equivalent to NSF Standard 61 for potable water.

#### 2.0 Connections

##### 2.1 Threaded style

- The female NPT threaded PVC end connectors shall conform to the dimensional standards ASTM D2464, ASTM F1498, and ANSI B1.20.1.

##### 3.0 Design Features

- The valve shall have true union ends.
- The valve opening and closing mechanism shall be a lever type shutter.
- A polypropylene thermal shield shall separate the valve body from the coil.
- The valve shall have a standard manual override.
- The valve shall have a standard light position indicator.
- The valve shall be rated 100% duty cycle.

##### 3.1 Pressure Rating

- Valve sizes ND 0.31" (1/4) shall be rated at 30psi at 73°F (23°C).
- Valve sizes ND 0.24" (1/4) and ND 0.39" (1/2) shall be rated at 60psi at 73°F (23°C).

##### 3.2 Markings

- All valves shall be marked to indicate size, material designation, and manufacturers name or trade mark.

##### 3.3 Color Coding

- All PVC valves shall be color-coded dark gray.

- 4.0** All valves shall be Xirtec® 140 by IPEX or approved equal.

## SF SERIES SOLENOID VALVES

### Dimensions and Weights

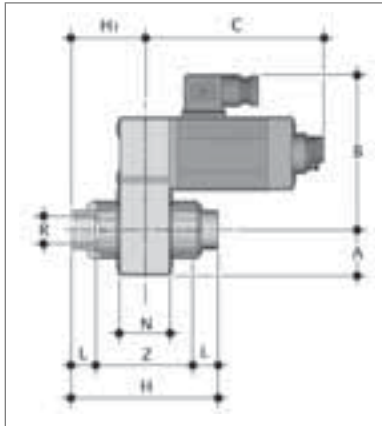

Dimension (inches)							
Size	ND	F (NPT)	A	B	C	E	F
1/4	0.24	3/8	0.89	4.13	3.50	1.54	3.43
1/4	0.31	3/8	0.89	4.13	3.50	1.54	3.43
1/2	0.39	3/8	1.28	4.78	4.29	2.05	4.45

Dimension (inches)							
Size	M	N	L	Z	H	H1	W (lbs)
1/4	1.97	1.18	0.63	2.36	3.62	1.81	0.95
1/4	1.97	1.18	0.63	2.36	3.62	1.81	0.95
1/2	2.56	1.38	0.63	2.80	4.06	2.03	2.34

### Electrical Data

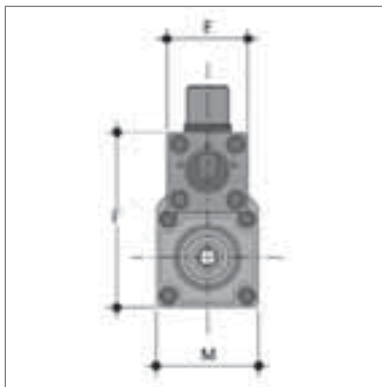

Duty Cycle	100% ED (DB)
Closing Time	~20ms
Opening Time	~20ms
AC Voltage	110V
Frequency	50/60Hz

Power Consumption	AC
1/4"	12VA
1/2"	20VA

Electrical Rating	NEMA 4
-------------------	--------

### Flow Coefficients

Size	ND	C <sub>v</sub>
1/4	0.24	0.77
1/4	0.31	0.95
1/2	0.39	2.33

### Pressure – Temperature Ratings

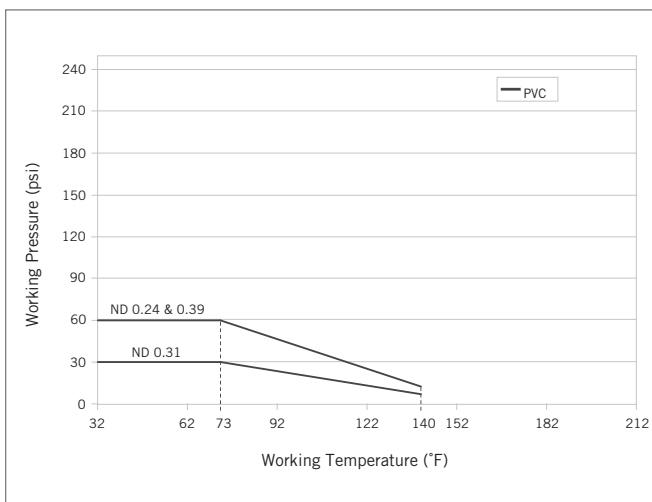

**Note:** The maximum ambient temperature allowed for the solenoid is 122°F (50°C).

### Pressure Loss Chart

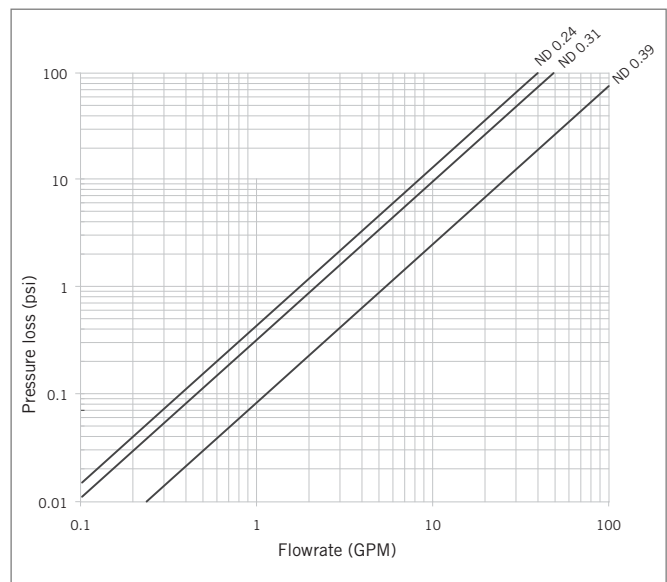

## SF SERIES SOLENOID VALVES

### Components

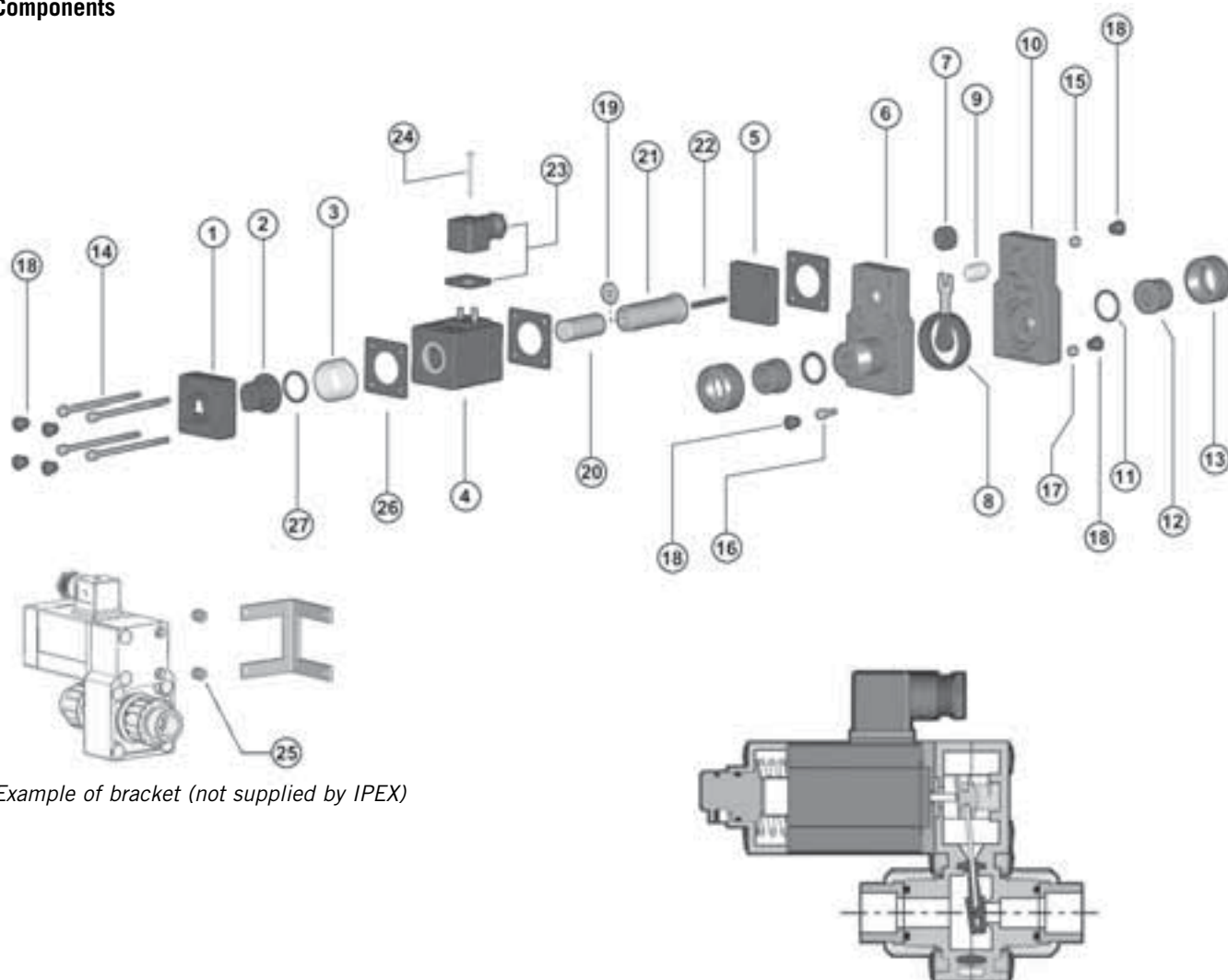

Example of bracket (not supplied by IPEX)

#	Component	Material	Qty
1	housing	GFPP	1
2	manual override	GFPP	1
3	spring	stainless steel	1
4	solenoid	-	1
5	cooling element	GFPP	1
6	upper body	PVC	1
7	spring slide	GFPP	1
8	shutter w/ seal	EPDM or Viton®	1
8	shutter arm	stainless steel	1
9	return spring	stainless steel	1
10	lower body	PVC	1
11	socket o-ring	EPDM or Viton®	2
12	end connector	PVC	2
13	union nut	PVC	2

#	Component	Material	Qty
14	bolts	zinc plated steel	4
15	nuts	zinc plated steel	4
16	bolts	zinc plated steel	4
17	nuts	zinc plated steel	4
18	protection caps	PE	16
19	washer	brass	1
20	movable core	stainless steel	1
21	sliding tube	stainless steel	1
22	control spindle	brass	1
23	connector	-	1
24	connector bolt	chrome plated steel	1
25	bracketing nuts	brass	-
26	flat seals	EPDM	2
27	o-ring seal	EPDM	1

## SF SERIES SOLENOID VALVES

### Installation Procedures

1. Remove the union nuts (part #13 on previous page) and slide them onto the pipe ends.
2. Thread the end connector (12) onto the pipe ends. For correct joining procedure, please refer to the section entitled, *“Joining Methods – Threading”* in the IPEX Industrial Technical Manual Series, *“Volume 1: Vinyl Process Piping Systems”*.
3. Ensure that the desired direction of pipe flow matches the indicated direction on the valve and that the socket o-rings (11) are properly fitted in their grooves. Carefully place the valve in the system between the two end connections.
4. Tighten both union nuts. Hand tightening is typically sufficient to maintain a seal for the maximum working pressure. Over-tightening may damage the threads on the valve body and/or the union nut, and may even cause the union nut to crack.
5. Remove the connector (23) from the solenoid (4), disassemble, and then connect the electrical leads. A wiring diagram can be found on the bottom of the connector.
6. Reassemble the connector and reattach to the solenoid.

**Note:** It is advisable to support the valve with a mounting bracket as the weight of the solenoid may cause the pipeline to sag.

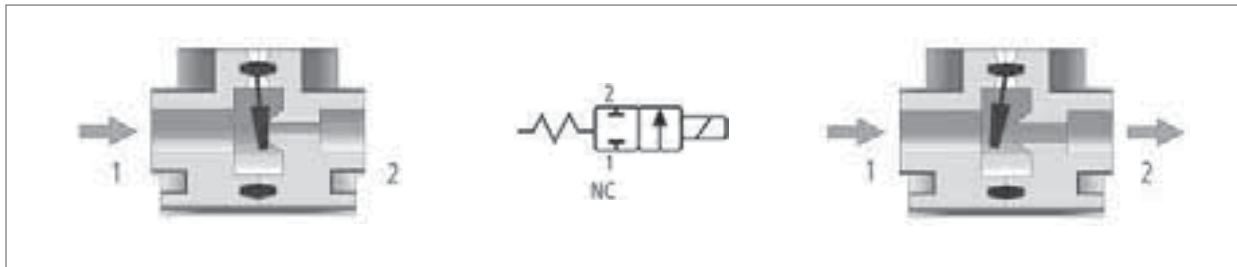

## SF SERIES SOLENOID VALVES

### Valve Maintenance

#### Disassembly

1. If removing the valve from an operating system, isolate the valve from the rest of the system. **Be sure to depressurize and drain the isolated branch and valve before continuing.**
2. Remove the connector (23) from the solenoid (4) and detach the electrical leads. Be sure to shut off the electrical source before detaching the leads.
3. Loosen both union nuts (13) and drop the valve out of the line. If retaining the socket o-rings (11), take care that they are not lost when removing the valve from the line.
4. Remove the protection caps (18) from all the bolt and nut holes.
5. Loosen the connector bolt (24) then remove the electrical connector (23) from the plug on the solenoid (4).
6. Loosen the four long bolts (14) and nuts (15) then carefully pull apart the entire solenoid assembly.
7. Disassemble the housing (1), manual override (2), the o-ring (27), and the control spring (3).
8. Pull apart the magnet assembly (4, 19, 20, 21, 22, and 26) and remove all components.
9. Remove the cooling element (5) and all the flat seals (26).
10. Loosen the four short bolts (16) and nuts (17), then pull apart the lower (10) and upper (6) bodies.
11. Remove the shutter assembly from the valve body then detach the spring slide (7) from the shutter arm (8).
12. Remove the return spring (9) from the spring slide.
13. All the valve components can now be checked for problems and/or replaced.

#### Assembly

**Note:** Before assembling the valve components, it is advisable to lubricate the o-rings with a water soluble lubricant. **Be sure to consult the “IPEX Chemical Resistance Guide” and/or other trusted resources to determine specific lubricant-rubber compatibilities.**

1. Fit the spring slide (7) into the slot on the shutter arm (8).
2. Attach the return spring (9) to the spring slide.
3. Carefully fit the shutter assembly into the lower body (10). Both the spring and the shutter arm should fit in the molded guides in the body. Correct installation will allow the shutter arm to act as a lever against the body.
4. Without moving the shutter assembly, fit the lower and upper (6) bodies together then fasten using the four short bolts (16) and nuts (17).
5. To assemble the magnet, place the following parts into the solenoid (4) according to the component diagram: The sliding tube (21) containing the fixed core, the control spindle (22), and the brass-washer (19) by inserting it in recess on the control spindle. Then insert the movable core (20) into the sliding tube on the opposite side of the solenoid.
6. Place a flat seal (26) in between the cooling element (5) and the upper body then position the remaining two seals on either side of the magnet assembly.
7. Position the completed magnet assembly (4, 19, 20, 21, 22, and 26) onto the cooling element with the plug orientated as per the component diagram. Ensure that the control spindle is guided into the cooling element hole.
8. Place the hand control spring (3) so that the protruding solenoid core moves inside the spring.
9. Carefully fit the o-ring (27) on the manual override (2), then insert into the housing (1). Ensure that proper fit occurs between the manual override, spring, and solenoid.
10. Fasten the entire assembly using the four long bolts (14) and nuts (15).
11. Fix the electrical connector (23) to the plug on the solenoid then tighten the connector bolt (24).
12. Use the protection caps (18) to cover all bolt and nut holes.
13. Ensure that the socket o-rings (11) are properly fitted in their grooves then attach the end connectors (12) and union nuts (13).



## LV SERIES LAB VALVES

IPEX LV Lab Valves are an ingenious PVC quarter turn product ideal for many simple plumbing applications. These compact, economical valves are supplied with an assortment of connections that match up with any kind of existing pipe or hose. LV Lab Valves are part of our complete Xirtec®140 systems of pipe, valves, and fittings, engineered and manufactured to our strict quality, performance, and dimensional standards.



ASTM D1784  
ASTM D2466  
ASTM F1498



ANSI B1.20.1

### Valve Availability

Body Material:	PVC
Size Range:	1/4"
Pressure:	150psi
Seats:	Teflon® (PTFE)
Seals:	EPDM
End Connections:	Threaded (FNPT), Hose Adapters

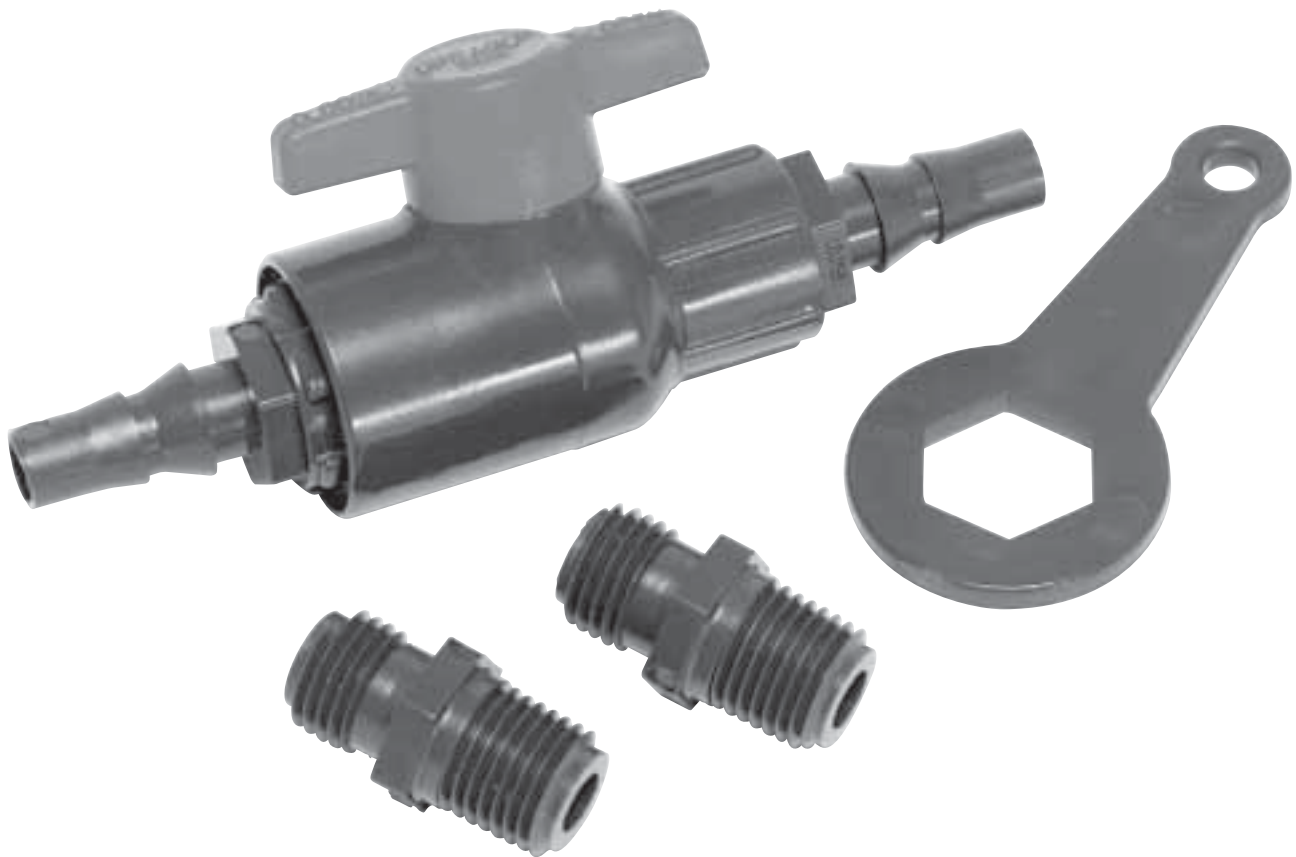

## LV SERIES LAB VALVES

### Sample Specification

#### 1.0 Lab Valves - LV

##### 1.1 Material

- The valve body and ball shall be made of PVC compound which shall meet or exceed the requirements of cell classification 12454 according to ASTM D1784.

##### 1.2 Seats

- The ball seats shall be made of Teflon® (PTFE).

##### 1.3 Seals

- The o-ring seals shall be made of EPDM.

#### 2.0 Connections

##### 2.1 Threaded style

- The male NPT threaded PVC end connections shall conform to the dimensional standards ASTM D2464, ASTM F1498, and ANSI B1.20.1.

##### 2.2 Hose Adapter style

- Hose adapters may be substituted for the male NPT threaded PVC end connections.

#### 3.0 Design Features

- The valve shall have a double stop polypropylene handle.
- The valve shall allow for bi-directional flow.

##### 3.1 Pressure Rating

- All valves shall be rated at 150psi at 73°F (23°C).

##### 3.2 Markings

- All valves shall be marked to indicate size, material designation, and manufacturers name or trade mark.

##### 3.3 Color Coding

- All PVC valves shall be color-coded dark gray.

- 4.0 All valves shall be Xirtec® 140 by IPEX or approved equal.

## LV SERIES LAB VALVES

### Dimensions and Weights

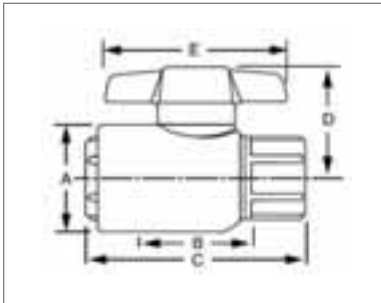

Size	Dimension (inches)					W (lbs)
	A	B	C	D	E	
1/4	1.06	0.94	2.13	1.06	1.75	0.10
1/4 w/kit	1.06	2.44	3.88	1.06	1.75	0.14

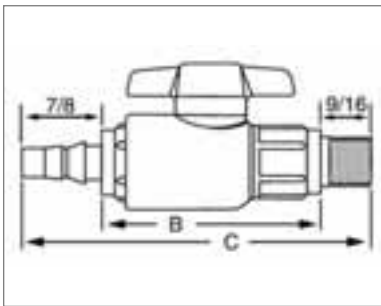

### Flow Coefficients

Size	C <sub>v</sub>
1/4	10.0
1/4 w/kit	6.00

### Pressure – Temperature Ratings

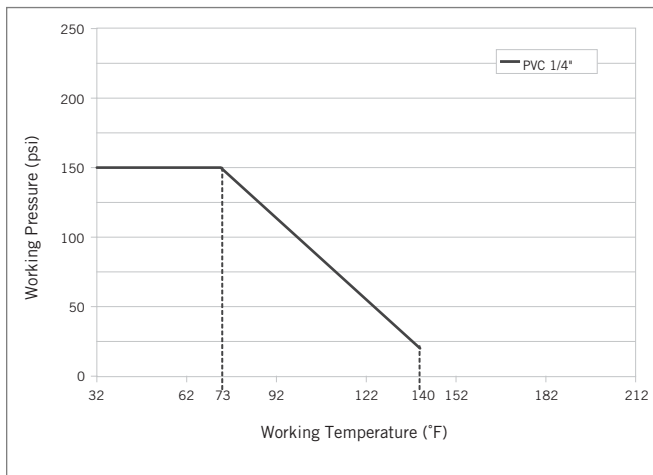

### Pressure Loss Chart

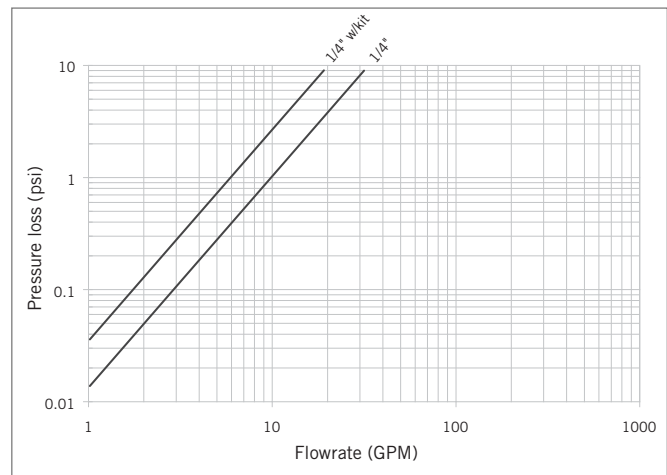

## LV SERIES LAB VALVES

### Components

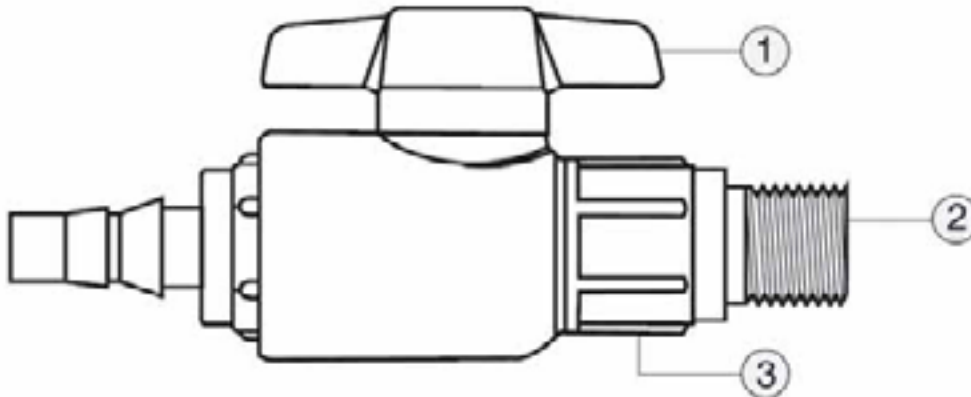

#	Component	Material	Qty
1	handle	PP	1
2	end connector	PVC	1
3	body	PVC	2

### Installation Procedures

1. Install the o-ring in the groove at the base of the threads on the desired end connector (part #2 on previous page).
2. Hand-tighten each end connector into the valve body (3). Do not use Teflon tape or thread sealant.
3. Tighten down the end connectors using the supplied plastic wrench. **Caution:** Over-tightening may cause damage to the valve body and/or end connectors.
4. Use the appropriate fittings or tube and ring clamps to connect the valve to the system.

### Removal From the System

1. If removing the valve from an operating system, isolate the valve from the rest of the system. **Be sure to depressurize and drain the isolated branch and valve before continuing.**
  2. Depending on the connection type, either loosen the fittings or ring clamps to remove the valve.
  3. The valve can now be reused and/or replaced.
- Note:** The LV Lab Valve has a one piece valve body. It cannot be disassembled.

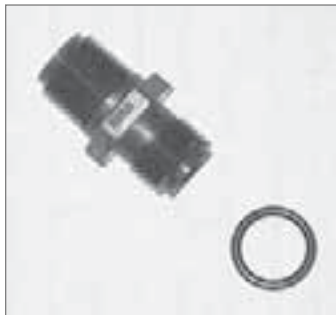

## SECTION SEVEN: STANDARDS

Standards exist to ensure that thermoplastic piping systems meet the required level of performance for a particular application. IPEX engineers and technical staff actively participate in thermoplastic standards development throughout North America. These activities result in new standards and improvements to existing standards for thermoplastic piping.

### Standards Organizations

IPEX products comply with standards developed by several standards organizations. Additional information on standards and compliance can be obtained by contacting the following organizations.

**ASTM International, [www.astm.org](http://www.astm.org)  
100 Barr Harbor Drive, West Conshohocken, Pennsylvania USA 19428-2959**

**ANSI, [www.ansi.org](http://www.ansi.org)  
1819 L Street, NW., Suite 600, Washington DC USA 20036**

**ISO, [www.iso.org](http://www.iso.org)  
1 rue de Varembé, Case postale 56, CH-1211 Geneva 20, Switzerland**

**NSF International, [www.nsf.org](http://www.nsf.org)  
P.O. Box 130140, 789 N. Dixboro Rd, Ann Arbor, Michigan USA 48113-0140**

### Applicable Standards

The following is a list of applicable standards for IPEX thermoplastic valves and related piping systems. This list is up-to-date at the time of printing.

#### ASTM

D1784	Standard Specification for Rigid Poly(Vinyl Chloride) (PVC) Compounds and Chlorinated Poly(Vinyl Chloride) (CPVC) Compounds
D1785	Standard Specification for Poly(Vinyl Chloride) (PVC) Plastic Pipe, Schedules 40, 80, and 120
D2464	Standard Specification for Threaded Poly(Vinyl Chloride) (PVC) Plastic Pipe Fittings, Schedule 80
D2466	Standard Specification for Poly(Vinyl Chloride) (PVC) Plastic Pipe Fittings, Schedule 40
D2467	Standard Specification for Poly(Vinyl Chloride) (PVC) Plastic Pipe Fittings, Schedule 80
D3222	Standard Specification for Unmodified Poly(Vinylidene Fluoride) (PVDF) Molding Extrusion and Coating Materials
D4101	Standard Specification for Polypropylene Injection and Extrusion Materials
F437	Standard Specification for Threaded Chlorinated Poly(Vinyl Chloride) (CPVC) Plastic Pipe Fittings, Schedule 80
F439	Standard Specification for Chlorinated Poly(Vinyl Chloride) (CPVC) Plastic Pipe Fittings, Schedule 80
F441/F441M	Standard Specification for Chlorinated Poly(Vinyl Chloride) (CPVC) Plastic Pipe, Schedules 40 and 80
F1498	Standard Specification for Taper Pipe Threads 60° for Thermoplastic Pipe and Fittings

## ANSI

- |         |                                   |
|---------|-----------------------------------|
| B1.20.1 | Pipe Threads, General Purpose     |
| B16.5   | Pipe Flanges and Flanged Fittings |

## ISO

- |         |   |
|---------|---|
| 10931   | Plastics piping systems for industrial applications - Poly(vinylidene fluoride) (PVDF) - Specifications for components and the system |
| 11922-1 | Thermoplastics pipes for the conveyance of fluids - Dimensions and tolerances - Part 1: Metric series                                 |

## NSF

- |        |  |
|--------|--|
| NSF 14 | Plastic Piping System Components and Related Materials |
| NSF 61 | Drinking Water System Components - Health Effects      |

**VALVE APPLICATION ASSISTANCE FORM**

**COMPLETE ALL SECTIONS AND FAX FORM TO 905-403-9195**



Date: \_\_\_\_\_

Originator: \_\_\_\_\_

End-User or Company: \_\_\_\_\_

Contact: \_\_\_\_\_

Address: \_\_\_\_\_

City: \_\_\_\_\_

State: \_\_\_\_\_ Zip: \_\_\_\_\_

Phone: \_\_\_\_\_ Ext. \_\_\_\_\_

Fax: \_\_\_\_\_

Name of Project: \_\_\_\_\_

IPEX Distributor: \_\_\_\_\_

Contact: \_\_\_\_\_

Fax: \_\_\_\_\_

Description of Application:

\_\_\_\_\_

\_\_\_\_\_

\_\_\_\_\_

\_\_\_\_\_

\_\_\_\_\_

\_\_\_\_\_

\_\_\_\_\_

\_\_\_\_\_

**Valve Details**

Valve Style:  Ball  Check or Vent  
 Butterfly  Diaphragm  
 Other: \_\_\_\_\_  
 Size: \_\_\_\_\_

Body Material:  PVC  PVDF  
 CPVC  PP  
 ABS  PP-n

Seal Material:  FPM  PTFE  
 EPDM  NBR  
 Other: \_\_\_\_\_

Accessories:  Lock-Out  Gear Operator  
 Limit Switches  Chain Wheel

If Actuated:  Electric Supply Voltage: \_\_\_\_\_  
 Approx # of cycles per hour? \_\_\_\_\_

Pneumatic  
 Air Supply Pressure? \_\_\_\_\_ psi g

Pilot Valve  3-Way or  4-Way

Fail Safe:  FC or  FO  
 Double Acting

Modulating  
 Input Signal? \_\_\_\_\_  
 What is the srt point? \_\_\_\_\_

Accessories:  Manual-Override  Stroke Limiter  
 Limit Switches  Speed Control  
 Other: \_\_\_\_\_

**Application Details:**

Fluid: \_\_\_\_\_ Concentration: \_\_\_\_\_ % Flow Rate:  gpm  lpm

Solids Content: \_\_\_\_\_ % Particle Size: \_\_\_\_\_ Installation:  Indoor  Outdoor

Ambient Temp: Min \_\_\_\_\_°F Max \_\_\_\_\_°F Exposed to sunlight?  Yes  No

Process Temp: Min \_\_\_\_\_°F Max \_\_\_\_\_°F Type: \_\_\_\_\_  Suspended  Support Required

Working Press: Min \_\_\_\_\_psi g Max \_\_\_\_\_psi g Type: \_\_\_\_\_



## SALES AND CUSTOMER SERVICE

Canadian Customers call IPEX Inc.

**Toll free: (866) 473-9462**

**[www.ipexinc.com](http://www.ipexinc.com)**

U.S. Customers call IPEX USA LLC

**Toll free: (800) 463-9572**

**[www.ipexamerica.com](http://www.ipexamerica.com)**

### **About the IPEX Group of Companies**

As leading suppliers of thermoplastic piping systems, the IPEX Group of Companies provides our customers with some of the largest and most comprehensive product lines. All IPEX products are backed by more than 50 years of experience. With state-of-the-art manufacturing facilities and distribution centers across North America, we have established a reputation for product innovation, quality, end-user focus and performance.

Markets served by IPEX group products are:

- Electrical systems
- Telecommunications and utility piping systems
- PVC, CPVC, PP, ABS, PEX, FR-PVDF and PE pipe and fittings (1/4" to 48")
- Industrial process piping systems
- Municipal pressure and gravity piping systems
- Plumbing and mechanical piping systems
- PE Electrofusion systems for gas and water
- Industrial, plumbing and electrical cements
- Irrigation systems

Products manufactured by IPEX Inc. and distributed in the United States by IPEX USA LLC.

This literature is published in good faith and is believed to be reliable. However it does not represent and/or warrant in any manner the information and suggestions contained in this brochure. Data presented is the result of laboratory tests and field experience.

A policy of ongoing product improvement is maintained. This may result in modifications of features and/or specifications without notice.

